

Study of Power Management System for Hybrid Renewable Solar and Wind Power Plant in Isolated Grid

¹Ravindrakumar M Desai, ²Assistant Prof. Ketan Bariya
¹P.G Student, ²Assistant Prof. at Sigma Institute of Engineering, Vadodara
¹Electrical Engineering
¹Sigma Institute of Engineering, Vadodara, India

Abstract— Due to the limited resources of fossil fuel and the concern of global warming, the development of renewable energy power system has rapidly progressed over the last decade. Solar energy and wind energy are the two most viable renewable energy resources in the world. Good compensation characters are usually found between solar energy and wind energy. In this paper at location of Gujarat State different location takes for an optimal design model for designing hybrid solar–wind systems for calculating the system optimum configurations and keeping that the annualized cost of the systems is minimized. This paper gives simulation results of PV-Wind hybrid system. HOMER (Hybrid Optimization Models for Energy Resources) power optimization software by NREL (National Renewable Energy Laboratory) is used to simulate and analyze the PV-Wind hybrid system. After that the Dynamic models of the proposed PV-Wind hybrid system have been developed using MATLAB/SIMULINK to investigate the system performance.

Keywords— Hybrid renewable energy, HOMER software, Dynamic models of Hybrid PV-Wind system

I. INTRODUCTION

The advantages of using renewable energy sources for generating power that there is increasing concern on the issues of climate change and global warming .The electric power generation system, which consists of renewable energy and with an energy storage system, is known as a hybrid power system. A hybrid power system has the ability to provide 24 hour grid quality electricity to the load. This system offers a better efficiency, flexibility of planning and environmental benefits compared to the diesel generator stand-alone system. The system also gives the opportunity for expanding its capacity in order to cope with the increasing demand in the future. This can be done by increasing either the rated power of renewable generator or both of them.

The disadvantage of standalone power systems using renewable energy is that the availability of renewable energy sources has daily and seasonal patterns which results in difficulties of regulating the output power to cope with the load demand. Also, a very high initial capital investment cost is required. Combining two or more renewable energy generation will enable the power generated from a renewable energy sources to be more reliable, affordable and used more efficiently.

This paper focuses on the combination of wind, solar and energy storing systems for sustainable power generation. The wind turbine output power varies with the wind speed at different conditions. The solar energy also varies with the hourly, daily and seasonal variation of solar irradiation. Thus, a battery bank (energy storage bank) can be integrated with the wind turbine(s) and PV-system to ensure that the system performs under all conditions. In the proposed system, when the wind speed is sufficient, the wind turbine can meet the load demand. When there is enough energy from the sun, the load demands can be supplied from the PV-array system. Whenever there is excess supply from the RESs, the energy storage bank stores energy which will be used at times when there are insufficient supplies from the RESs.

HOMER software can be used for this purpose, which are: To analyze the cost of a hybrid system before installation, To find out the cost effective sizes and combinations of the necessary components in the system and To analyze the cost of an already built or existing system.

After that the Dynamic models of the proposed PV-Wind hybrid system have been developed using MATLAB/SIMULINK to investigate the system performance.

II. HOMER SOFTWARE

HOMER, an optimization model is used to simulate the system. Large number of options are available for different size of the components used, components to be added to the system which make sense, cost functions of components used in the system. HOMER's optimization and sensitivity analysis algorithms evaluated the possibility of system configuration.

The system cost calculations account for costs such as capital, replacement, operation and maintenance, fuel and interest. It shows set of all possible variables in the system configuration. HOMER simulates all possible configurations and sorts them according to net present cost (NPC).

In this simulation, sensitivity variables are PV arrays and wind speed. HOMER simulates Solar and Wind as renewable resources. The hybrid system simulation shows the optimized system for different system sensitivity variables.

III. SOLAR RADIATION AND WIND SPEED FOR DIFFERENT LOCATION

Solar radiation and wind speed for different location in Gujarat State. This Solar radiation and Wind speed obtain from NASA site.

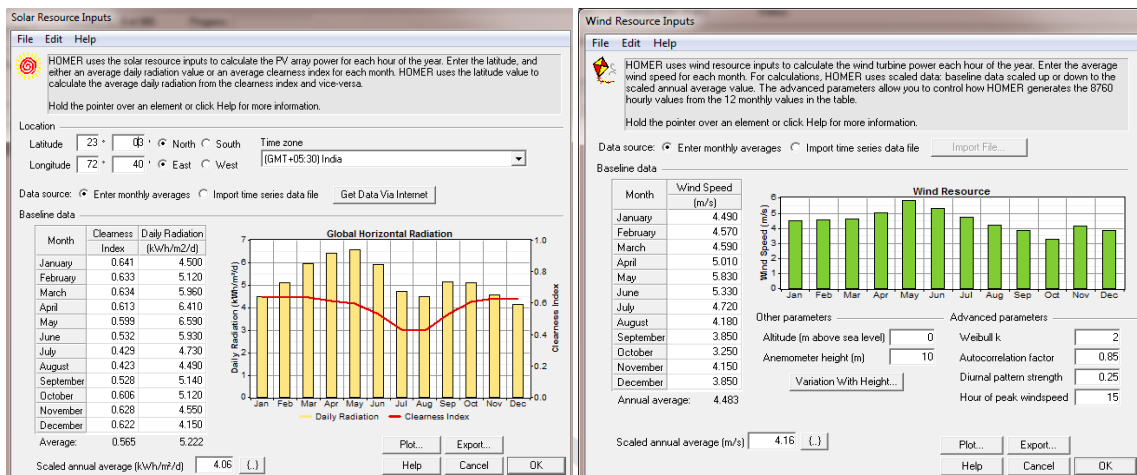

Figure1: Solar radiation and wind speed for Ahmedabad location

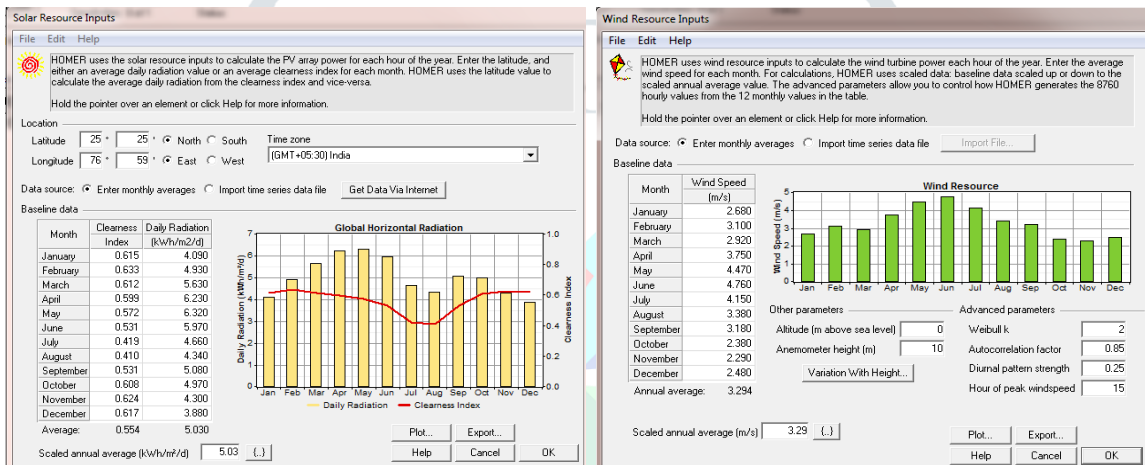

Figure2: Solar radiation and wind speed for Vadodara location

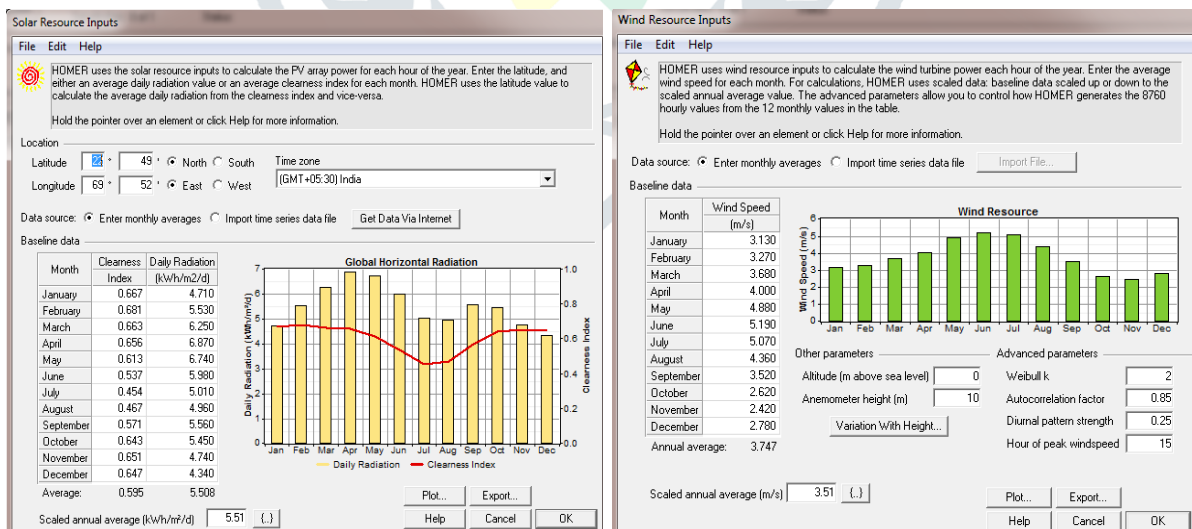

Figure3: Solar radiation and wind speed for Mundra location

IV. SOLAR-WIND HYBRID POWER SYSTEM

Now consider 1 kW PV panel, 1kW Wind turbine, 1kW Inverter, 1battery of 200Ah. Generally 1 kW PV panel generates 4 units per day and 1 kW wind turbine generates 3 units per day so this system should be used for loading condition of 7 kWh/day. Hear considering 1\$ = 50 INR

Table 1: Equipment details

Equipment	Rating	Cost(INR)	Lifetime(years)
PV	1kW	180000	20
Wind Turbine	1kW	125000	15
Battery	12V 200Ah	10000	3
Converter	1kW	10000	20

Calculation:

$$\begin{aligned} \text{Total Capital cost} &= \text{Cost of PV panel} + \text{Cost of wind turbine} + \text{Cost of Battery} + \text{Cost of Converter} \\ &= 180000 + 125000 + 10000 + 10000 \\ &= 325000 \end{aligned}$$

$$\begin{aligned} \text{Cost per year} &= \frac{\text{Cost of PV panel}}{\text{Life time of PV panel}} + \frac{\text{Cost of Wind Turbine}}{\text{Life time of Wind Turbine}} + \frac{\text{Cost of Battery}}{\text{Life time of Battery}} + \frac{\text{Cost of Converter}}{\text{Life time of Converter}} \\ &= \frac{180000}{20} + \frac{125000}{15} + \frac{10000}{3} + \frac{10000}{20} \\ &= 21166.7 \end{aligned}$$

$$\begin{aligned} \text{Total cost per year} &= \text{Cost per year} + \text{Operating \& Maintenance cost} + \text{discount rate} \\ &= 21166.7 + 2116.67 + 2116.67 \\ &= 25400 \end{aligned}$$

In above equation Operation and maintenance cost and discount cost is 10% of cost per year.

$$\begin{aligned} \text{Cost of energy} &= \frac{\text{Total cost per year}}{\text{Generation per year}} \\ &= \frac{25400}{4 \times 365 + 3 \times 365} \\ &= 10\text{Rs/kWh} \end{aligned}$$

For 10kWh/day and 100kWh/day loading are Simulation result for different location and calculation are done.

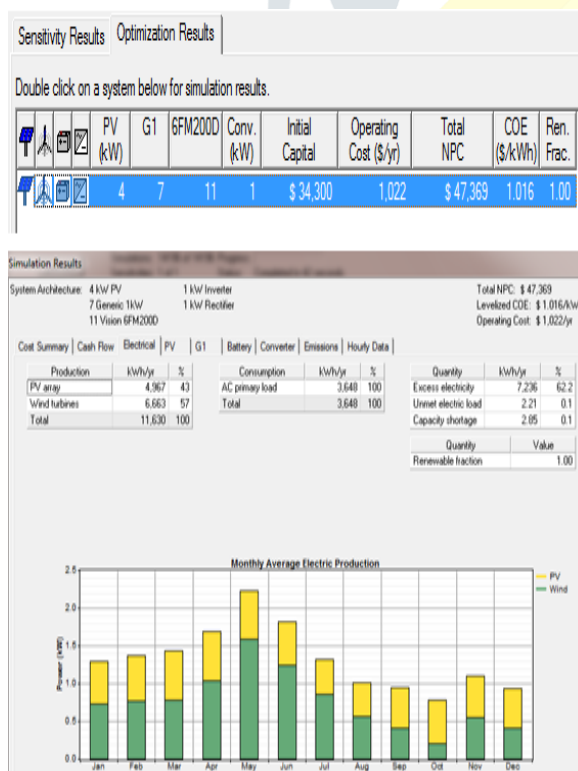

Figure 4: 10kWh/day for Ahmedabad location

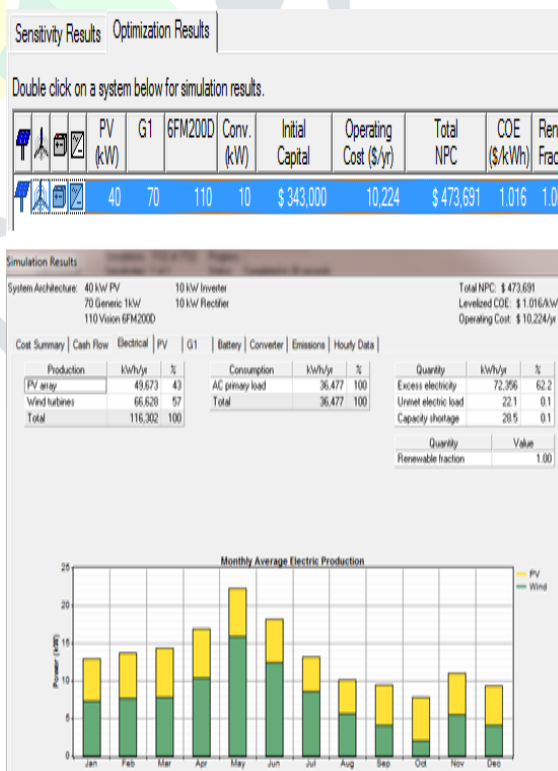

Figure 5: 100kWh/day for Ahmedabad location

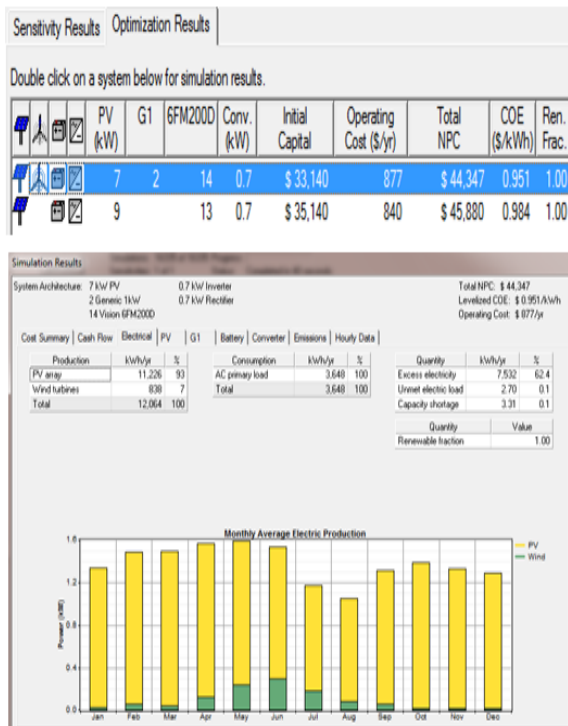

Figure 6: 10kWh/day for Vadodara location

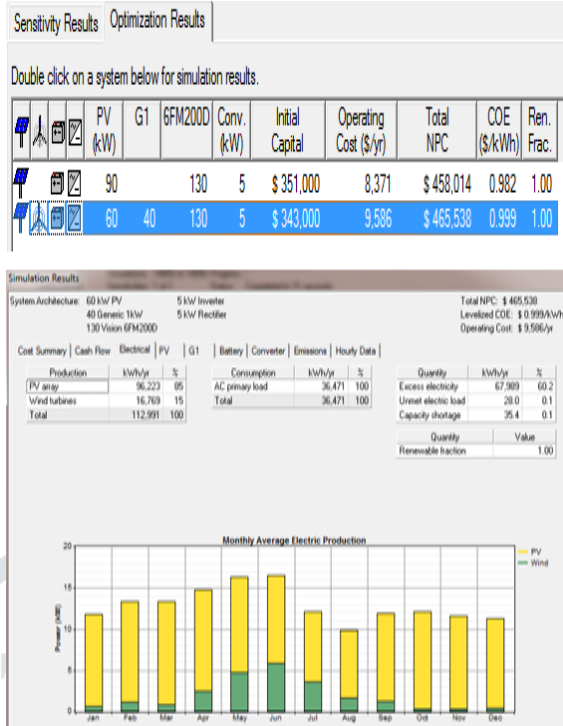

Figure 7: 100kWh/day for Vadodara location

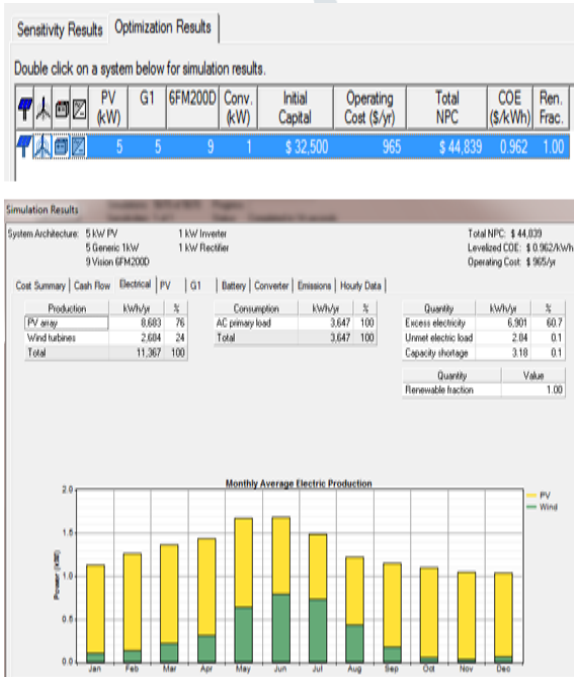

Figure 8: 10kWh/day for Mundra location

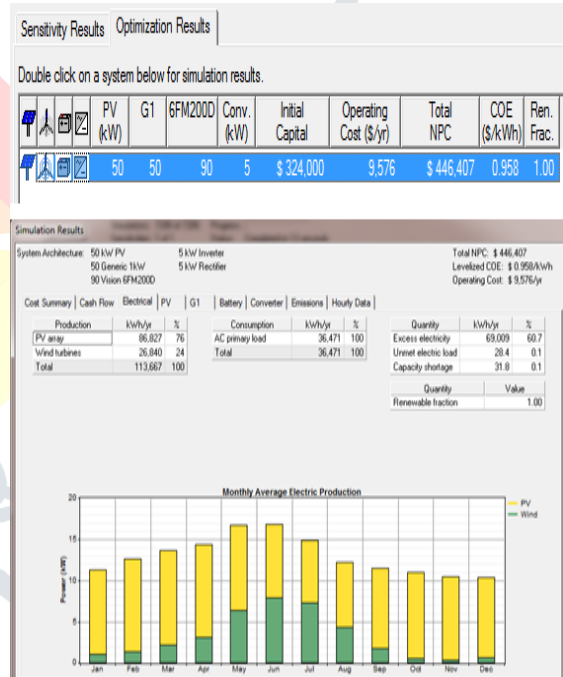

Figure 9: 100kWh/day for Mundra location

Below table-2 shows the calculation result for three different location for 10kWh/day loading. In below table IC means Initial Capital cost which is in rupees. TEP means total electricity production over year by PV panel and wind turbine. COE means Cost of Energy which is INR per kWh.

Table 2 : Calculation result for 10 kWh/day for three location

	Ahmedabad	Vadodara	Mundra
PV	4	7	5
WT	7	2	5
Battery	11	14	9
Converter	2	0.7	1
IC	1725000	1657000	1625000
TEP	13505	12410	12775
COE	10	12	11

Below table-3 shows the calculation result for three different location for 100kWh/day loading. In below table IC means Initial Capital cost which is in rupees. TEP means total electricity production over year by PV panel and wind turbine. COE means Cost of Energy which is INR per kWh.

Table 3 : Calculation result for 100 kWh/day for three location

	Ahmedabad	Vadodara	Mundra
PV	40	60	50
WT	70	40	50
Battery	110	130	90
Converter	10	5	5
IC	17150000	17150000	16200000
TEP	135050	131400	127750
COE	9	10	10

With the help of simulation, the cost of energy(COE) production is calculated for Ahmedabad, Vadodara, Mundra It can be concluded that for increasing loading condition of unit per day the cost of energy production is per unit is decrease, where for the load of unit per day, the cost of energy production reduces to per unit. So it is proved that as loading condition increases per day, the cost per unit will reduce.

V. DYNAMIC MODELS OF THE PROPOSED PV-WIND HYBRID SYSTEM

Energy power management strategies and dynamic models of the proposed hybrid system have been developed using MATLAB/SIMULINK to investigate the system performance.

a) Modeling of a Solar Cell

A solar cell is the building block of a solar panel. A photovoltaic module is formed by connecting many solar cells in series and parallel. Considering only a single solar cell; it can be modeled by utilizing a current source, a diode and two resistors. This model is known as a single diode model of solar cell.

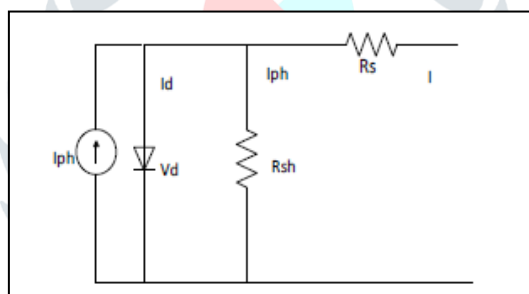

Figure 10 : Single diode model of a solar cell

The characteristic equation for a photovoltaic cell is given by,

$$I = I_{ph} - I_d - I_{sh} \tag{1}$$

$$I = I_{ph} - I_o [\exp \{q (V+R_s I)/(A K_B T)\} - 1] - (V+R_s I)/R_{sh} \tag{2}$$

Where, I_{ph} = photocurrent, I_d = diode current, I_o = saturation current, A = ideality factor, K_B = Boltzmann’s gas constant (1.38×10^{-23}), q = electronic charge 1.6×10^{-19} , T = cell temperature, R_s = series resistance, R_{sh} = shunt resistance, I = cell current, V = cell voltage

The characteristic equation of a solar module is dependent on the number of cells in parallel and number of cells in series. It is observed from experimental results that the current variation is less dependent on the shunt resistance and is more dependent on the series resistance.

$$I = I_{ph} - I_o [\exp\{qV/kT\} - 1] \tag{3}$$

b) Wind Turbine

The turbine is that the 1st and foremost part of wind generation systems. Wind turbines capture the facility from the wind by means that of aerodynamically designed blades and convert it to rotating mechanical power. This mechanical power is delivered to the rotor of an electrical generator wherever this energy is reborn to electricity. Electrical generator used is also associate degree induction generator or synchronous generator.

The mechanical power that is generated by the wind is given by:

$$P_w = \frac{P}{2} C_p(\lambda, \beta) A_r V_w^3 \tag{4}$$

Where, ρ - Air density , A - Rotor swept area , $C_p(\lambda, \beta)$ - power coefficient function, λ - Tip speed ratio, β - Pitch angle, V_w -wind speed

The wind power generation system in Fig. 1 is the type of doubly-fed induction generator (DFIG). The system model consists of a wind turbine blade, DFIG, a pitch angle controller and a back-to-back converter. The wind turbine and the doubly-fed induction generator (WTDFIG) are shown in the figure called The Wind Turbine and the Doubly-Fed Induction Generator System. The AC/DC/AC converter is divided into two components: the rotor-side converter (C_{rotor}) and the grid-side converter (C_{grid}). C_{rotor} and C_{grid} are Voltage-Sourced Converters that use forced-commutated power electronic devices (IGBTs) to synthesize an AC voltage from a DC voltage source. A capacitor connected on the DC side acts as the DC voltage source. A coupling inductor L is used to connect C_{grid} to the grid. The three-phase rotor winding is connected to C_{rotor} by slip rings and brushes and the three-phase stator winding is directly connected to the grid. The power captured by the wind turbine is converted into electrical power by the induction generator and it is transmitted to the grid by the stator and the rotor windings. The control system generates the pitch angle command and the voltage command signals V_r and V_{gc} for C_{rotor} and C_{grid} respectively in order to control the power of the wind turbine, the DC bus voltage and the reactive power or the voltage at the grid terminals.

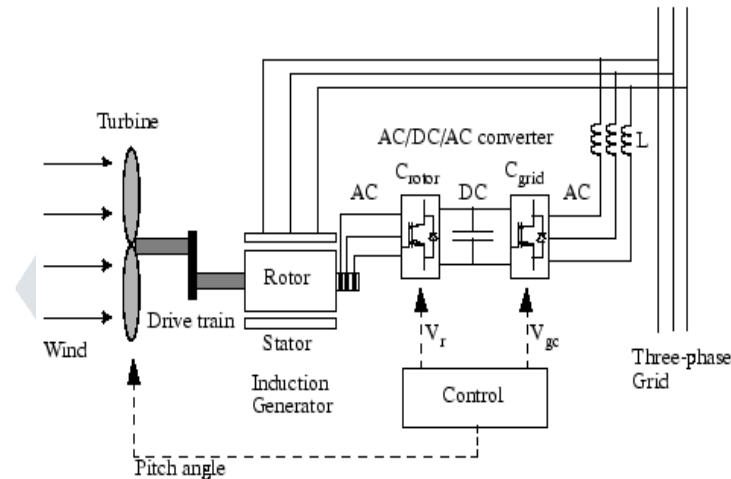

Figure 11: Wind Turbine and the Doubly-Fed Induction Generator System

c) *Cuk Converter*

The Cuk converter is a type of DC-DC converter that has an output voltage magnitude that is either greater than or less than the input voltage magnitude. It has the capability for both step up and step down operation. The output polarity of the converter is negative with respect to the common terminal. This converter always works in the continuous conduction mode.

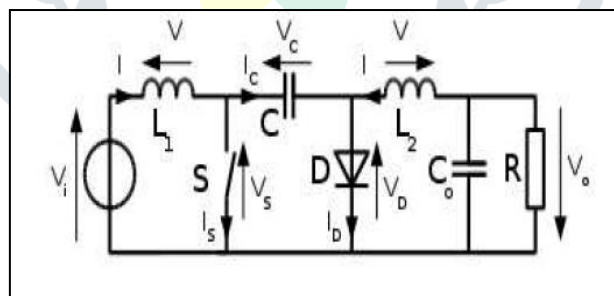

Figure 12: Cuk Converter

The voltage conversion ratio M_{CUK} of the Cuk converter is given by:

$$V_o = - V_{in} [D/(1-D)] \tag{5}$$

d) *SEPIC Converter*

Single-ended primary-inductor converter (SEPIC) is a type of DC-DC converter allowing the voltage at its output to be greater than, less than, or equal to that at its input. It is similar to a buck boost converter. It has the capability for both step up and step down operation. The output polarity of the converter is positive with respect to the common terminal.

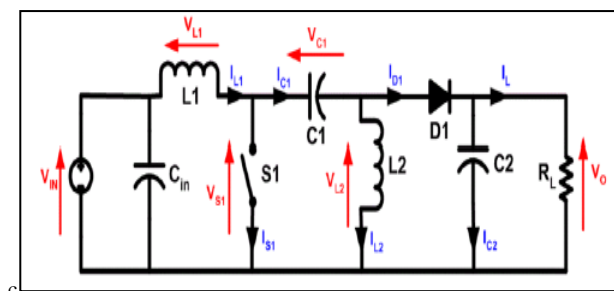

Figure 13: SEPIC converter

The voltage conversion ratio M_{SEPIC} of the SEPIC converter is given by:

$$V_o = V_{in} [D/(1-D)] \quad (6)$$

e) Proposed Hybrid system (PV-Wind)

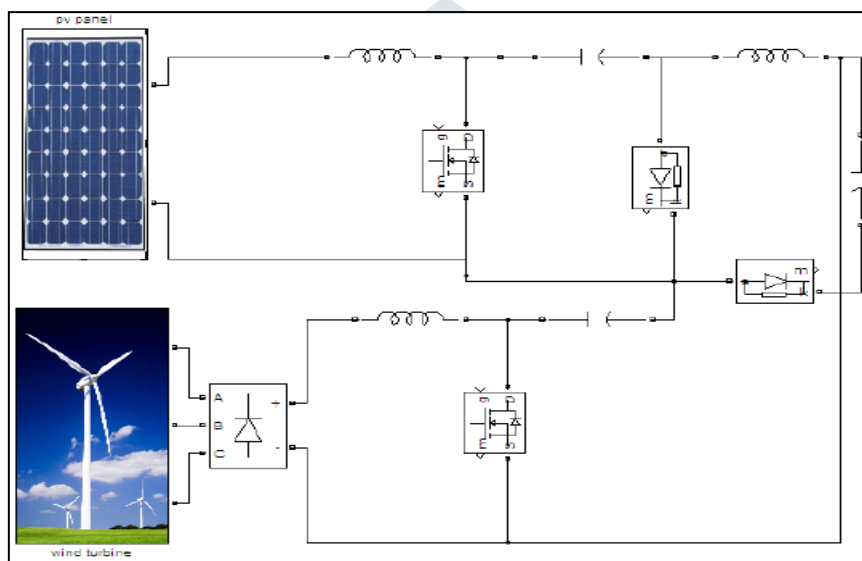

Figure 14: Hybrid PV-Wind model with converter

VI. CONCLUSION

The results of HOMER shows that the cost of energy production reduces to per unit .So it is proved that as loading condition increases per day, the cost per unit will reduce .The cost summary, cash flow summary, electrical production or emissions and cost of PV-Wind hybrid system is feasible. Then after dynamic models of the proposed hybrid system have been developed using MATLAB/SIMULINK to investigate the system performance In this topology, both wind and PV energy sources are incorporated together using a combination of Cuk and SEPIC converters, so that if one of them is unavailable, then the other source can compensate for it.

VII. ACKNOWLEDGMENT

I am grateful to Mr. Jaydeepkumar Senjaliya and Mr Nirav for his valuable suggestions and guidance given by them. I would like to thank the Teaching & Non- teaching staff of Department of Electrical Engineering for sharing their knowledge with me.

REFERENCES

- [1] Mohamed El Badawe, Tariq Iqbal, George K.I.mann, "Optimization and Modeling of Stand-Alone Wind/PV Hybrid Energy System" 25th IEEE Canadian Conference on Electrical and computer Engineering (CCECE)-2012
- [2] Parita G Dalwadi,Chintan R Mehta, "Feasibility Study of Solar-Wind Hybrid Power System" International Journal of Emerging Technology and Advanced Engineering(ISSN 2250-2459, Volume 2, Issue 3, March 2012)
- [3] Bindu U Kansara , B.R. Parekh,"Modeling and Simulation of Distributed Generation System Using HOMER Software" International Conference on Recent Advancements in Electrical, Electronics and Control Engineering 2011
- [4] K.R. Ajao ,O.A.Oladosu, O.T. Popoola " USING HOMER POWER OPTIMIZATION SOFTWARE FOR COST BENEFIT ANALYSIS OF HYBRID-SOLAR POWER GENERATION RELATIVE TO UTILITY COST IN NIGERA" IJRRAS April 2011

- [5] M. Jain, Dr.B. E. Kushare “TECHNO-ECONOMICS OF SOLAR WIND HYBRID SYSTEM IN INDIAN CONTEXT: A CASE STUDY” IET-UK International Conference on Information and Communication Technology in Electrical Sciences (ICTES 2007), Dr. M.G.R. University, Chennai, Tamil Nadu, India. Dec. 20-22, 2007. pp. 39-44.
- [6] Anant Shukla, Anurag Shukla, Karmendra Pandey, Arti Saxena “Implementation of Novel Hybrid Wind Solar Energy Conversion System” National Student Conference On “Advances in Electrical & Information Communication Technology” AEICT-2014
- [7] Jianwu Zeng, Wei Qiao, Liyan Qu, and Yanping Jiao, “An Isolated Multiport DC–DC Converter for Simultaneous Power Management of Multiple Different Renewable Energy Sources” IEEE Journal of emerging and selected topics in power electronics, Vol.2, No.1, March 2014, 2168-6777.
- [8] Tripti Saha, Sushma Kakkar and Deependra Kumar Jha “Fused Converter Topology for Wind-Solar Hybrid Systems” IEEE -2013
- [9] Teena Jacob and Arun S, “Modeling of hybrid wind and photovoltaic energy system using a new converter topology” Electrical and Electronics Engineering: An International Journal (EEEIJ) Vol.1, No.2, August 2012.
- [10] www.nrel.gov/homer
- [11] NASA Atmospheric Science Data Centre
<http://eosweb.larc.nasa.gov>

