

DESIGN AND ANALYSIS OF 24 PULSE AC-DC CONVERTER

Mr S Dinesh Kumar¹ , Abhilash Dwivedi² , Pranshita Gupta³ , Shubham Sachan⁴

Dept. of Electronics & Instrumentation Engineering

Galgotias College of Engineering & Technology , Greater Noida, Uttar Pradesh- 201308, India

Abstract—This paper proposes a non-isolated 24-pulse controlled AC-DC converter for medium power rating drives. The proposed AC-DC converter configuration consists of a polygon auto transformer to overcome current harmonic problems in AC mains. It improves power quality at AC mains and it meets IEEE-519 standard requirements at varying loads. A set of power quality indices on input AC mains and on DC buses for a load fed from 6-pulse and 12-pulse AC-DC converters is also given to compare their performance. The proposed 24-pulse AC-DC converter is found capable of suppressing up to the 21st harmonics in the supply current along with the power-factor improvement close to unity in the wide operating range of the drive. It involves pulse multiplication in a 12-pulse AC-DC converter. It is observed that input current total harmonic distortion (THD) of less than 8% is possible with the proposed topology of AC-DC converter at varying loads.

Keywords-- 24-pulse, AC-DC Converter, Power Quality, Thyristor Bridge, Pulse Multiplication, Polygon Autotransformer.

I. INTRODUCTION

The current harmonics are problems in AC-DC converters because they cause increased losses in the customer and utility power system components. 6 or 12 pulse controlled AC-DC converters result results in the injection of harmonics current in ac main supply which do not meet the IEEE -519 standard requirements. The power factor and harmonics distortion can be improved by increasing the number of pulse of AC-DC converter . If six pulse controlled AC-DC converters are directly connected to ac mains, then six pulse of AC-DC converter causes injection of harmonics at input and affect the power quality. To improve power quality at input, some researchers have also rearranged the main transformer windings to suppress the input current harmonics and increase the number of pulse of AC-DC converter. The two sets of three phase output voltage are connected to AC-DC converter thyristor bridges connected in parallel. ZSBT is used on the DC side to eliminate the zero sequence current. Interphase reactors are used in this design which performs the process of pulse multiplication i.e. conversion of 12 pulse converter to 24 pulses. The AC-DC converter are used for dc drives, synchronous machine control , battery chargers, power suppliers (dc and ups) and High voltage dc transmission(HVDC).

II. PROPOSED 24-PULSE AC-DC CONVERSION APPROACH

In this paper, a 24-pulse controlled AC-DC converter is used for feeding non-isolated loads. The method uses a polygon-wound autotransformer of small rating, a ZSBT and a tapped interphase reactor (IPR). The converter configuration is designed and the control is developed and power quality indices are estimated using MATLAB along with Simulink and Power System Blockset (PSB) toolboxes.

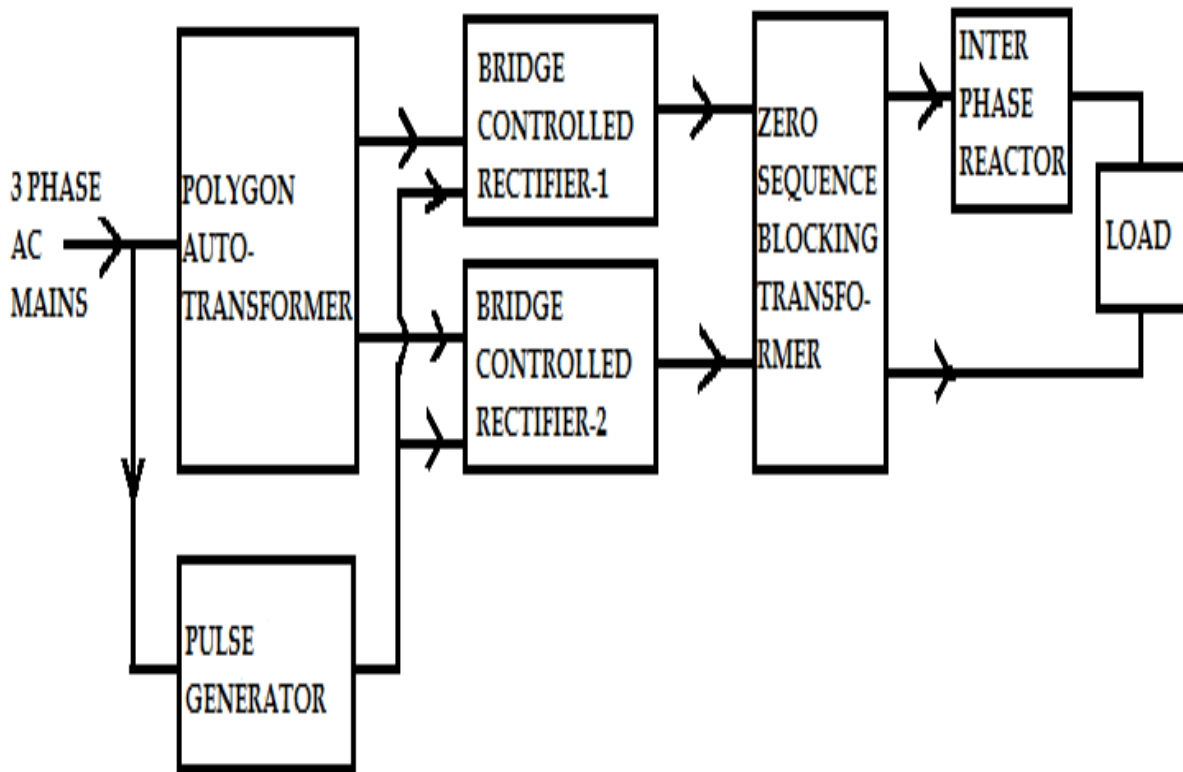

Figure 1: Block diagram of 24-pulse AC-DC converter

a) DESIGN OF THE AUTOTRANSFORMER FOR 12-PULSE AC-DC CONVERTERS

The minimum phase shift required for proper harmonic elimination is given by [5]
 phase shift = 60°/number of converters.

For achieving 12-pulse ac–dc conversion, the phase shift between the two sets of voltages may be either of 0° and 30° or ±15° with respect to the supply voltages. In this paper, the autotransformer based on ±15° phase shift has been considered to reduce the size of the magnetics. From the supply voltages, two sets of 3-phase voltages (phase shifted through +15° and –15°) are produced. The number of turns required for +15° and –15° phase shift are calculated. The number of turns for every winding is determined as a function of the primary phase voltage, V_A . Fig. 2 shows the winding-connection diagram of the proposed polygon autotransformer.

$$V'_a = V_a + K_1 V_c - K_2 V_b \tag{1}$$

$$V'_a = V_a + K_1 V_b - K_2 V_c \tag{2}$$

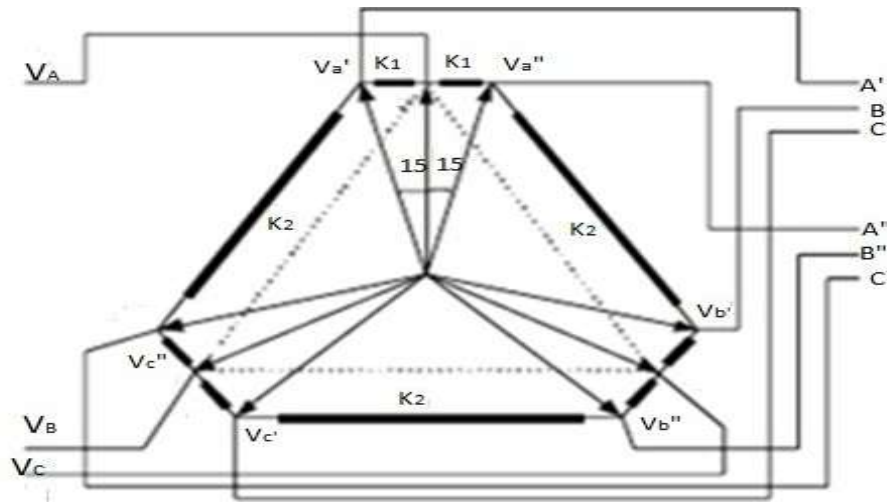

Figure 2: Polygon autotransformer

Assume the following set of voltages:

$$V_a = V \angle 0^\circ, V_b = V \angle -120^\circ, V_c = V \angle 120^\circ \tag{3}$$

$$V'_a = V \angle 15^\circ, V'_b = V \angle -105^\circ, V'_c = V \angle 135^\circ \tag{4}$$

Where $V_a, V_b,$ and V_c are the phase voltages.

Similarly,

$$V''_a = V \angle -15^\circ, V''_b = V \angle -135^\circ, V''_c = V \angle 105^\circ \tag{5}$$

Where V is the rms value of the phase voltage. Using the above equations, K_1 and K_2 can be calculated. These equations result in $K_1 = 0.1835$ and $K_2 = 0.1153$ for the desired phase shift in the autotransformer. Thus

$$V'_a = V_a + 0.1835V_c - 0.1153V_b \tag{6}$$

$$V''_a = V_a + 0.1835V_b - 0.1153V_c \tag{7}$$

A phase-shifted voltage V'_a is obtained by tapping a portion (0.1835) of phase voltage V_c and connecting one end of an approximate (0.1153) of the phase voltage V_b . Thus, the autotransformer can be designed with these known values of winding constant K_1 and K_2 . Due to the 24-pulse operation, the average voltage at dc link is higher than the output voltage of a 6-pulse diode-bridge rectifier by about 2.8%. The proposed autotransformer design is modified to make it suitable for retrofit applications. The kilovoltampere rating of the transformer is calculated

$$\text{Equivalent KVA rating} = 0.5 \frac{V_{winding} \cdot I_{winding}}{1000} \tag{8}$$

where $V_{winding}$ is the voltage across each winding of the autotransformer, and $I_{winding}$ is the current flowing through the same winding at full load.

b) BRIDGE CONTROLLED RECTIFIER

A rectifier is an electrical device that converts alternating current (AC), which periodically reverses direction, to direct current (DC), which flows in only one direction. The process is known as **rectification**. The simple process of rectification produces a type of DC characterized by pulsating voltages and currents (although still unidirectional). Depending upon the type of end-use, this type of DC current may then be further modified into the type of relatively constant voltage DC characteristically produced by such sources as batteries and solar cells. Rectifiers have many uses, but are often found serving as components of DC power supplies and high-voltage direct current power transmission systems.

SIX PULSE BRIDGE RECTIFIER-

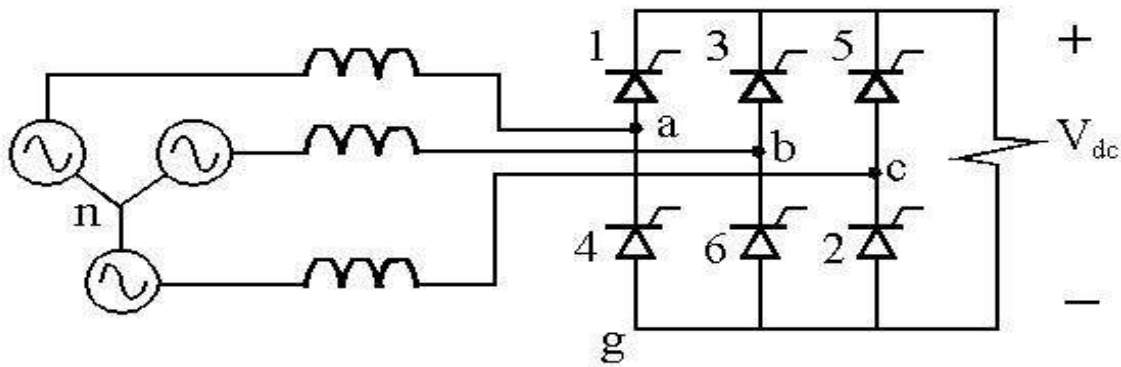

Figure 3: Bridge controlled rectifier

A six-pulse controlled bridge rectifier connected to an ideal three-phase source with commutating inductances included in each phase. First considering the operation of an uncontrolled rectifier without commutating inductances circuit as shown in figure except the thyristors are replaced by diodes and the inductors are removed. Without commutation, only two diodes will conduct at any time, one on the top half of the bridge and one on the bottom half of the bridge. Also in order to have a voltage across the load, the two conducting diodes must be in different legs of the bridge e.g. diodes 1 and 4 cannot be on at the same time. Thus the voltage applied to the DC load consists of a portion of a line to line voltage from the three phase source.

c) ZERO SEQUENCE BLOCKING TRANSFORMER

The zero sequences blocking transformer is used for controlled 24-pulse AC-DC converter. The function of ZSBT is used in achieving independent 6-pulse operation of the two rectifier bridges, which eliminates the unwanted conducting sequence of the rectifier diodes or thyristors. It exhibits high impedance to zero-sequence currents. ZSBT is used on the DC side for power quality improvement. It is also used for independent operation of two bridges and eliminates the unwanted conducting sequences of the converter. In non isolated AC-DC converters; a path for zero sequence currents is available through the autotransformer windings. It leads to unequal conduction in upper and lower thyristors of the two bridges. This theory has been used to design a completely new and innovative transformer that integrates the treatment of zero sequence harmonics as well as 5th & 7th harmonics. These transformers may be configured as single or multiple output units to accommodate various design strategies. The function of ZSBT is used in achieving independent. It exhibits high impedance to zero-sequence currents, resulting in 120° conduction for each diode of the bridges and also results in equal current sharing in the output. Moreover, it exhibits high impedance to zero-sequence currents, thereby allowing symmetrical conduction of each diode. The voltage across ZSBT depends on the conduction sequence of the diodes, and it is shown in Fig. 7. Mathematically, V_{ZSBT} can be expressed as [8]

$$V_{ZSBT}(\omega t) = V_{LL} \{-0.25 \cos(3\omega t) + 0.07 \sin(6\omega t) + 0.03 \cos(9\omega t) + \dots\}. \tag{9}$$

The previous equation shows that the lowest frequency component of the voltage waveform across ZSBT (V_{ZSBT}) is 150 Hz, i.e., corresponding to the third harmonic, and it contains only triplen harmonics, as shown in Fig. 7. This results in smaller size, weight, and volume of the transformer. Here, V_{LL} is the rms supply-line voltage.

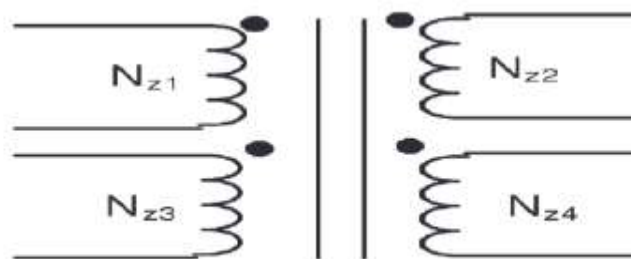

ZSBT diagram.

Figure 4: ZSBT diagram

d) INTERPHASE REACTOR

The interphase reactor, along with the two diodes, is shown in the fig. it shows that, when the voltage V_m is positive, the diode D_1 becomes forward biased, and the full-load current flows through this diode.

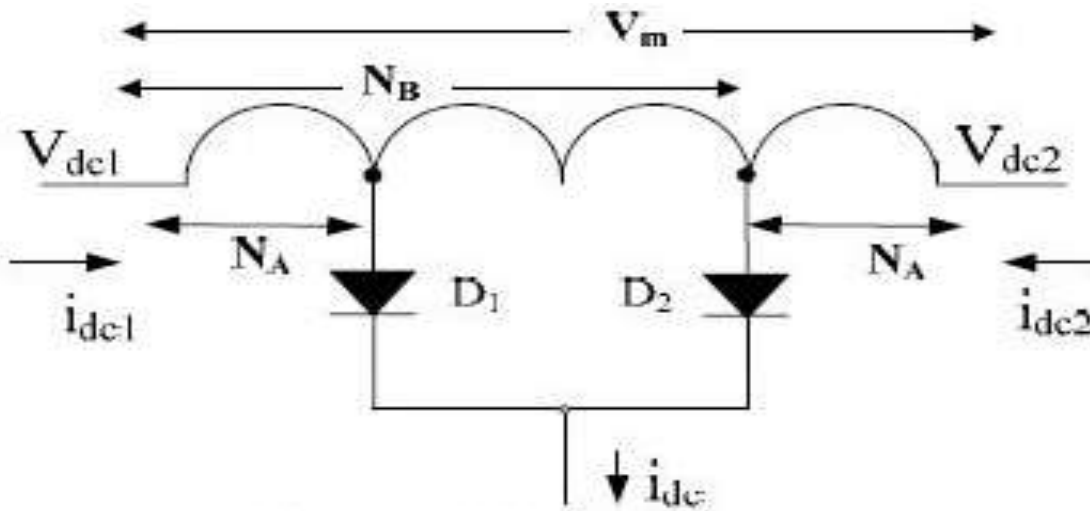

Figure 5: IPR diagram

A required condition to achieve the pulse doubling is to ensure that the instantaneous output voltages of the two converters, D_1 and D_2 , are the same and displaced by an angle of 30° . Therefore, depending on the polarity of voltage V_m , the magnitudes of the converter output currents are modulated and this changes the shape of the rectifier input currents and, thereby, doubles the pulses. From the magneto motive force (MMF) relationship of the interphase reactor, it can be written as

$$I_{d1} = (0.5 + k)i_{dc} \tag{10}$$

$$I_{d2} = (0.5 - k)i_{dc} \tag{11}$$

Similarly, when the voltage V_m is negative, diode D_2 becomes forward biased, and the full-load current flows through this diode. From the MMF relationships of the interphase reactor, it can be written as,

$$I_{d1} = (0.5 - k)i_{dc} \tag{12}$$

$$I_{d2} = (0.5 + k)i_{dc} \tag{13}$$

It is observed that the polarity of the voltage V_m modulates the output current i_{d1} and i_{d2} . Therefore, depending upon the polarity of the impressed voltage across the interphase reactor, diodes D_1 or D_2 conduct, resulting in pulse doubling. The value of k has been selected to be 0.26 to eliminate the harmonics up to the 22nd order. The voltage appearing across the interphase reactor V_m is an AC voltage ripple of six times the source frequency, resulting in smaller size, weight, and volume of the transformer. Fig. shows the waveform of the diode currents showing the changeover of currents through the diodes, and this results in achieving the 24-pulse characteristics. Two bridge output voltages v_{dc1} and v_{dc2} rectifier output voltage v_{dc} is given by

$$v_{dc} = 1/2(v_{dc1} + v_{dc2}) \tag{14}$$

Similarly, the voltage across the interphase reactor is given by

$$V_m = v_{dc1} - v_{dc2} \tag{15}$$

where v_m is an ac voltage ripple of six times the source frequency.

III. MATLAB BASED SIMULATION

A set of 6-pulse, 12-pulse and 24-pulse AC-DC converters are modeled and simulated in a MATLAB environment along with Simulink and Power System Blockset (PSB) toolboxes.

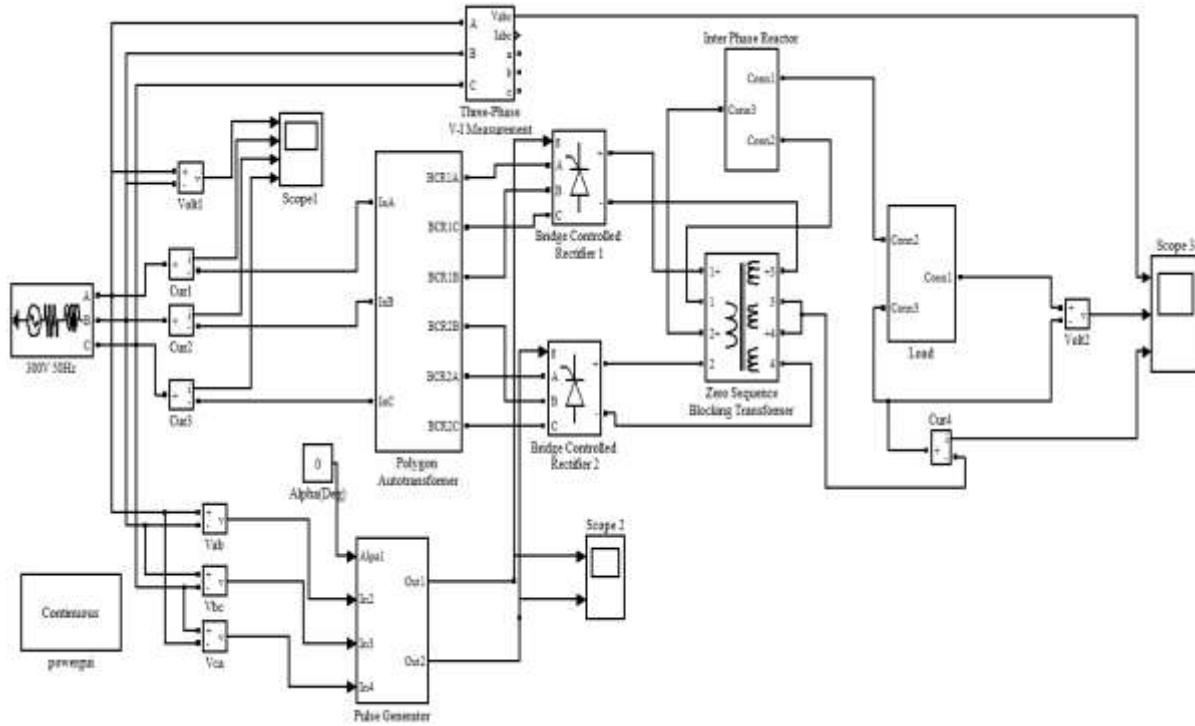

Figure 6: MATLAB model of 24-pulse AC-DC converter.

IV. RESULTS, DISCUSSION AND CONCLUSION

The power quality indices from simulation of the proposed controlled 24-pulse AC-DC converter are given in table in comparison with that of 12-pulse AC-DC converter. It can be seen that the load power at a 75° firing angle is around 6% of the full load and a value of the firing angle above 60° will be required during transient conditions only. It can be seen in fig 7 that the input current (i_a) has 24 step in one cycle of AC supply. The improvement in power quality indices, such as THD of supply current (THD), THD of supply voltage (THD), distortion factor and PF, at different firing angles is shown in fig 8. It can be seen that the THD of the input AC current of the proposed 24-pulse AC-DC converter system is less than 5% and the current waveform is almost sinusoidal and in phase with the supply voltage. It can be observed that the 24-pulse AC-DC converter has a significantly improved performance. The value of THD at PCC is higher than that desired from a 24 pulse AC-DC converter due to communication notches.

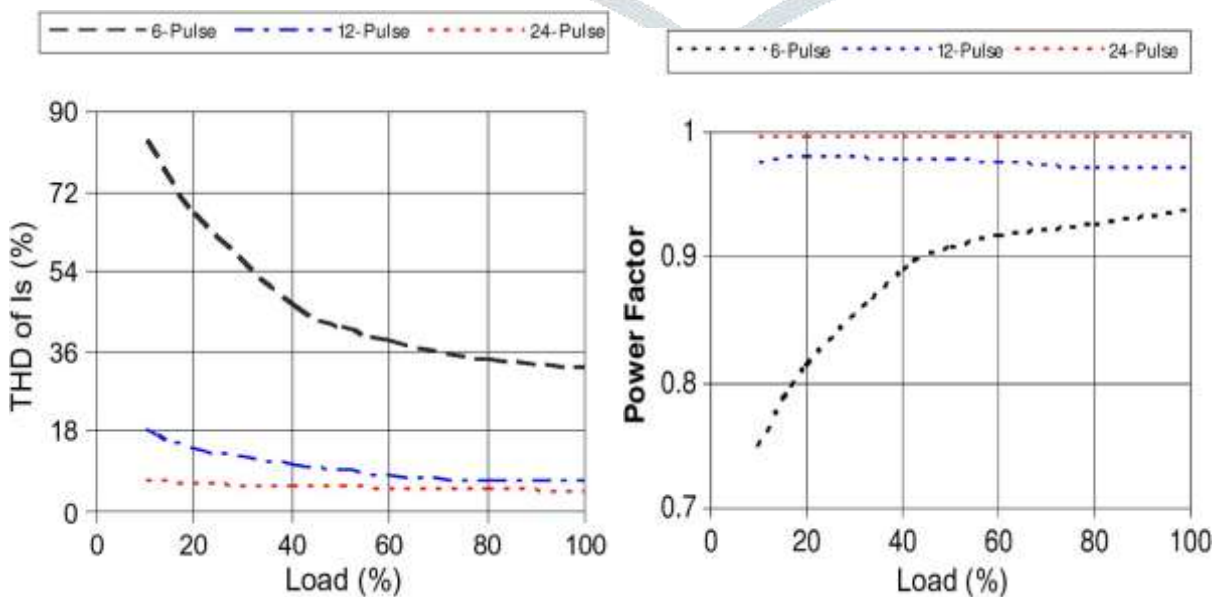

Figure 8: THD and Power Factor of 24-pulse AC-DC converter

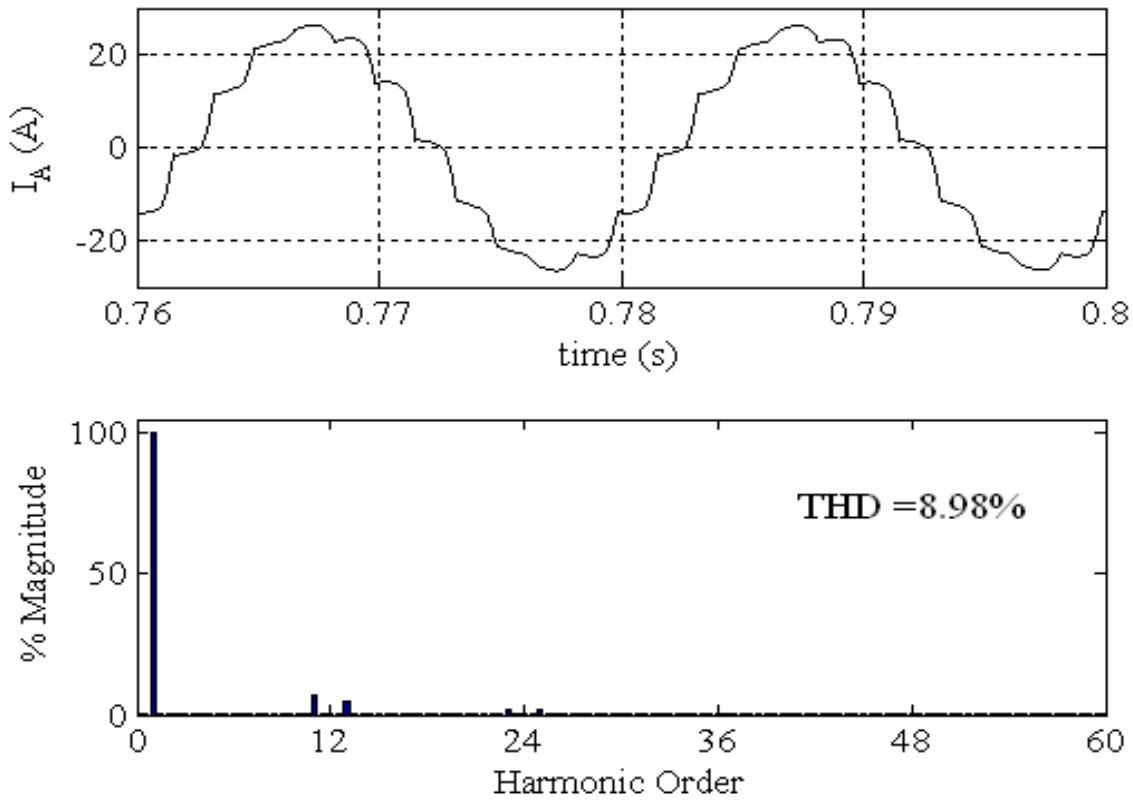

Figure 9 : input current and total harmonic distortion



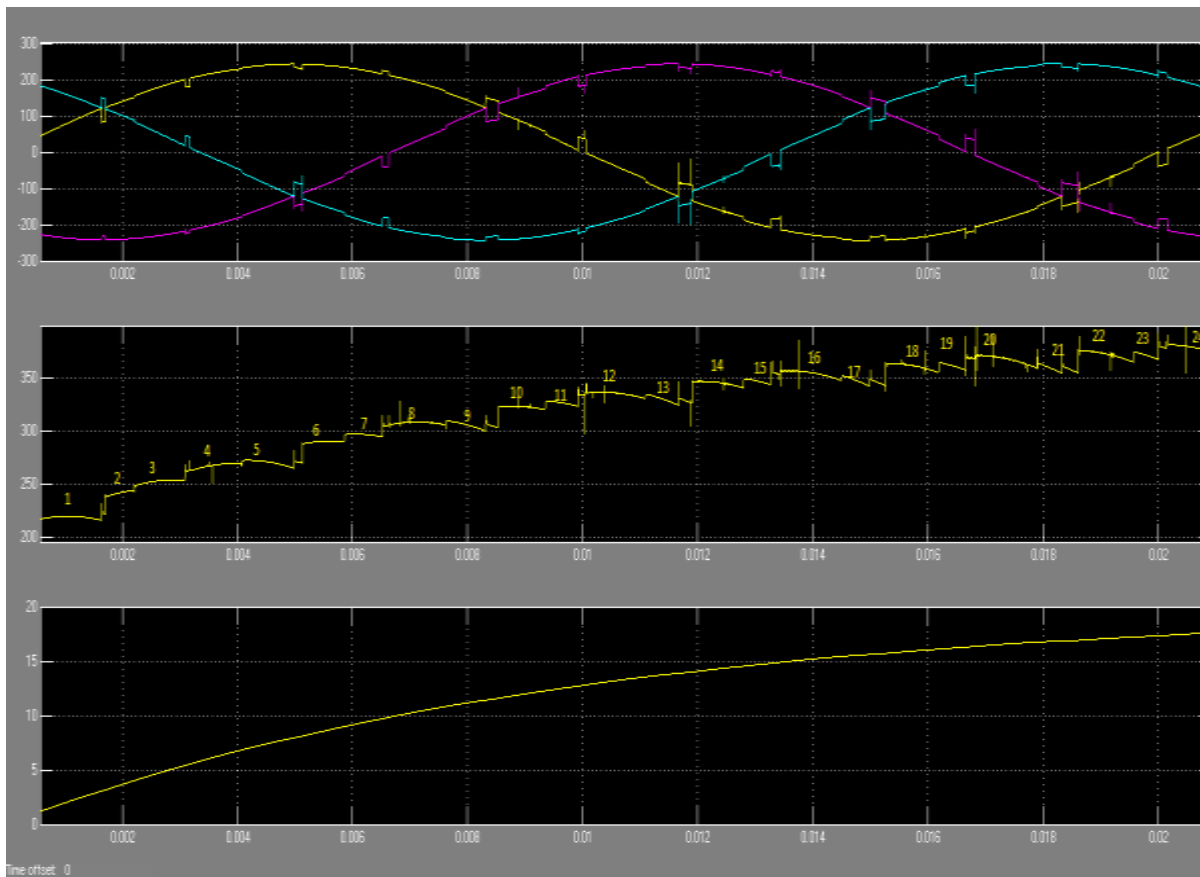

Figure 7: Input and output waveforms of 24-pulse controlled AC-DC converter

V. REFERENCES

[1] P. Vas, *Sensorless Vector and Direct Torque Control*, Oxford University Press, 1998.
 [2] Limits for Harmonic Current Emissions, International Electrotechnical Commission Standard 61000-3-2, 2004.
 [3] IEEE Guide for Harmonic Control and Reactive Compensation of Static Power Converters, IEEE Standard 519-1992.
 [4] D. A. Paice, *Power Electronic Converter Harmonics: Multipulse Methods for Clean Power*, New York: IEEE Press, 1996.
 [5] Bin Wu, *High-Power Converters and AC Drives*, IEEE Press, Wiley-Interscience, 2006.
 [6] S. Choi, P. N. Enjeti, and I. J. Pitel, "Polyphase transformer arrangements with reduced kVA capacities for harmonic current reduction in rectifier type utility interface", *IEEE Trans. on Power Electronics*, Vol. 11, No. 5, pp. 680–689, September 1996.
 [7] P. W. Hammond, "Autotransformer", U.S. Patent No. 5619407, April 8, 1997.
 [8] D. W. Owens, "Autotransformer for Use with Multiple Phase Rectifiers", US Patent 7049921, May 23, 2006.
 [9] S. Choi, B. S. Lee, and P. N. Enjeti, "New 24-pulse diode rectifier systems for utility interface of high power AC motor drives", *IEEE Trans. on Industry Applications*, Vol. 33, No. 2, pp. 531–541, March/April 1997.
 [10] B. Singh, G. Bhuvaneswari, V. Garg, "Power-quality improvements in vector-controlled induction motor drive employing pulse multiplication in AC-DC converters" *IEEE Trans. on Power Delivery*, vol. 21 no. 3, pp. 1578 –1586, July 2006,