

# Automobile Refrigerator Using Waste Heat Of IC Engine

<sup>1</sup>Khande R. R., <sup>2</sup>More A.S., <sup>3</sup>Pawar T. M., <sup>4</sup>Dabade N. M

B.E.(Mechanical)

<sup>1</sup>SBPCOE,Indapur

<sup>2</sup>SBPCOE,Indapur

<sup>3</sup>SBPCOE,Indapur

<sup>4</sup>SBPCOE,Indapur

Guide :Prof.R.D.Ankush

**Abstract**— Recovering energy from engine exhaust gases that could potentially reduce vehicle fuel consumption by up to 10 percent. The TIGERS Turbo-generator Integrated Gas Energy Recovery System consortium (a Foresight vehicle project) diverts exhaust gases to drive a small switched reluctance generator to create enough electricity to power a cars electrical system. International environment protection initiatives have led to the intensification of research efforts on development of ozone and global warming safe heat technology.

The energy loss from the vehicle can be utilized to operate the Vapor Absorption Refrigeration System (VARS), hence reducing the excessive work done by the engine. Keeping this in mind, this paper explores the possibilities of utilizing the VAC in moving vehicles for the purpose of cold storage.

## INTRODUCTION

An energy management system will ensure optimal utilization of the available energy. During highway driving, when the available exhaust energy is high, However, at engine idle the penalty for recovery is high and so the vehicle will be operated in battery only mode. The researchers have looked at placing the new at various locations along the exhaust system. Placed too far away from the engine, the waste gases start to lose energy, so in the development stage the generator has been placed just beneath the exhaust manifold to maximize energy recovered. The gases then pass through the catalytic converter after the turbine, to ensure that the gases can still be conventionally cleaned. By placing it close to the manifold the energy available is optimized. This also allows for shorter runs for control leads and coolant pipes and provides greater protection to the unit. Disadvantages are that the high temperatures mean the generator has to be water cooled and totally sealed. However, the researchers are convinced that they can fully develop the system and plan to have a fully operating prototype ready for bench testing within a few months. Because the system is fairly simple and partly based on existing technology, it could be fully developed for all car, van, bus and truck engines within a few years. The simple design of the switched reluctance generator enables a low cost and easy to manufacture unit to be built that can run reliably at high speeds. It gives the TIGERS device a power density of approximately three times that of a typical alternator. An efficiency in excess of 80 percent can be achieved compared with 60percentfor traditional technology. Dr Richard Quinn, one of the engineers leading the TIGERS project, says the system could be developed to produce anything from 12v to

600v. The recovered energy could power all of a cars heating, lighting, air conditioning and in-car entertainment systems. Longer term, the cam belt, drive belts and alternator could be scrapped with the TIGERS-recovered power providing electrical drive instead for further potential for gains in engine efficiency.

## SCOPE

The engine waste heat can be recovered by using exhaust gases as source /generator for VARS. The arrangement of various components of refrigeration system is also a challenge because of the fixed size of vehicles. In the proposed model condenser and evaporator will be arranged same as the conventional unit.

## Vapor-compression refrigeration cycle

Vapor-compression refrigeration cycle is the popular refrigeration cycle in today's life. This is due to the factors like relatively efficient, inexpensive and compact. A system is composed of four major components namely: a compressor, condenser, thermal expansion valve and an evaporator. A liquid refrigerant circulates through the system, absorbing and releasing heat producing a cooling effect in a confined space. The refrigerant enters the compressor as a saturated vapor at point (1) in figure 1. As the refrigerant is compressed it increases in temperature and leaves the compressor as a superheated vapor. The superheated vapor enters the condenser, at point (2), which is generally a coiled or finned tube cooled by air or water. At this point the refrigerant releases heat to the surroundings through convection and changes phase from a superheated vapor to a saturated liquid as the refrigerant cools to below its saturation temperature. The liquid is then funneled through the expansion valve, as indicated by point (3), where the sudden drop in pressure causes flash evaporation of the saturated liquid to a saturated vapor resulting in a temperature drop of the refrigerant which occurs because the drop in pressure across the expansion valve simultaneously lowers the refrigerant's saturation temperature. This change in temperature corresponds to the enthalpy of vaporization of the given refrigerant. The refrigerant only partially evaporates because the cooling produced from initial evaporation lowers the refrigerant temperature back to below its saturation temperature. The cold liquid-vapor mixture continues on to the evaporator, point (4), where it absorbs heat and fully vaporizes. This is the final stage, which accounts for the cooling in the refrigeration cycle. The vapor then enters the compressor, completing the cycle.

Common household cycles run at efficiencies of roughly 50% of Carnot's theoretical limit, which is about five times more efficient than the other refrigeration cycles (Jernqvist,

1993). Because a small amount of refrigerant liquid can produce a large amount of cooling, the system can be compact and still be efficient. This allows it to be both space saving and inexpensive.

Despite all of the advantages, the vapor-compression refrigeration process still has few disadvantages i.e. the system uses hydro chlorofluorocarbon (HCFC) refrigerants. These refrigerants contribute to the depletion of the o-zone layer and adversely affect the environment. Most systems that don't use HCFC refrigerants use hydro fluorocarbon (HFC) refrigerants. HFCs contribute to global warming and are generally less efficient (Devotta S.A.V, 2001).

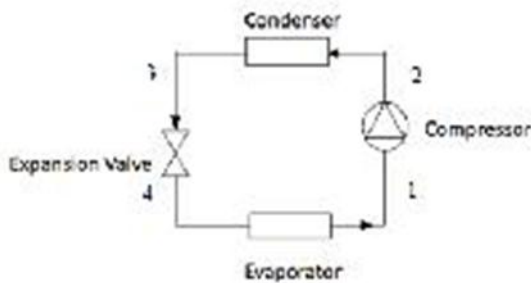

Fig 1 - Vapor Compression Cycle

**Vapor Absorption System**

Absorption is the process of attracting and holding moisture by substances called desiccants. Desiccants are sorbents, i.e., materials that have an ability to attract and hold other gases or liquids, which have a particular affinity for water. During absorption the desiccant undergoes a chemical change as it takes on moisture, as for example the table salt, which changes from a solid to a liquid as it absorbs moisture. The characteristic of the binding of desiccants to moisture makes the desiccants very useful in chemical separation processes. Ammonia-Water combination possesses most of the desirable qualities which are listed below:

- 1m<sup>3</sup> of water absorbs 800m<sup>3</sup> of ammonia (NH<sub>3</sub>).
- Latent heat of ammonia at -15°C = 1314 kJ/kg.
- Critical temperature of NH<sub>3</sub> = 132.6°C.
- Boiling point at atmospheric pressure = -33.3°C

The NH<sub>3</sub>-H<sub>2</sub>O system requires generator temperatures in the range of 125°C to 170°C with air-cooled absorber and condenser and 80°C to 120°C when water-cooling is used. Ammonia is highly soluble in water and this ensures low solution circulation rates. Both constituents are obtainable at minimal cost. The choice of Ammonia-water combination is not made without considering certain disadvantages: ammonia attacks copper and normally water boils at 100°C. However, for every pound of pressure increase, the boiling point increases by 3°F. The temperature of the coolant can sometimes reach 250 to 275°F (121 to 135°C). Even with ethylene glycol added, these temperatures would boil the coolant, so something additional must be done to raise its boiling point. Typical radiator cap pressure is 12 to 16 psi. This raises the boiling point of the engine coolant to about 250°F to 260°F. Many surfaces inside the water jackets can be above 212°F.

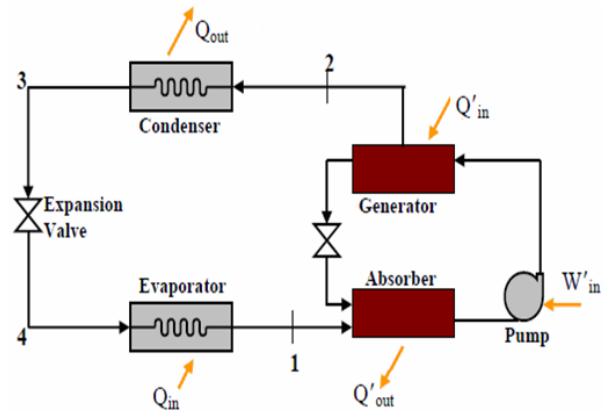
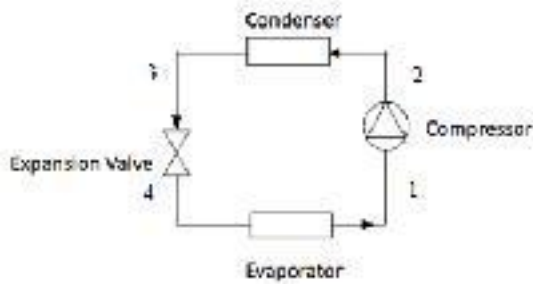

Fig 2 - Vapor Absorption System [10]

**LITERATURE SURVEY**

There are various works available on the Absorption cooling with exhaust gas heat of engine. But, no significant work has been carried out by recovering and utilizing Engine heat in refrigeration system of a vehicle.

The goal of this project is to create a source of cooling unit, which will aid the billions of people without electricity and refrigeration. This project has many possible positive applications from chilled water generation, air conditioning, cooling beverages for sale in remote areas to producing ice for commercial/medical use, with the main goal targeting to achieve the temperature which can be used in different applications. Absorption refrigeration is the most reliable and prominent for this kind of applications. These units are using low grade energy and use it for driving absorption generators for cooling this they are explained use of ammonia with exhaust gas temp energy for absorption refrigeration and getting the best results if evaporator temperature 11C after 1 hrs absorption. Also in Home power - 53, Mr. Stevan Vanek gives the experimentation done by some non-regular absorbent material for exhaust gas absorption system. He had use ammonia and calcium chloride as refrigerant absorbent pair instead if regular Ammonia water pair. We are following the same system with different configuration of setup for experimenting the performance of that system. We have some other papers having experience the same kind of technology by various ways to compete the objectives. Department of mechanical Engg. University Of Hong-Kong also experienced the various ways to do this process by Mr. K.Sumathy they are using absorption technique with domestic charcoal and at plate exhaust gas collector as generator. While we are trying to do with exhaust gas Concentrator for supplying the exhaust gas. Also the same work is done in Exhaust gas Energy Journal, is The new exhaust gas Power absorption refrigerator with higher performance by Catherine Hildbrand, and Philippe Dinde. The absorption pair is silica gel + water. The machine does not contain any moving parts, does not consume any mechanical energy except for experimental purposes and is relatively easy to manufacture. Cylindrical tubes function as both the absorber system and the exhaust gas the condenser is air-cooled and the evaporator contains 40 l of water that can freeze. This ice functions as a cold storage for the cabinet.



**POTENTIAL OF HEAT RECOVERY FROM THE ENGINE OF THE VEHICLE**

Waste heat, which is generated by fuel combustion in the engine, and is then dissipated into the environment even though it could still be reused for some useful and economic purpose. This heat depends on the temperature of the waste heat gases and mass flow rate of exhaust gas. Waste heat losses arise both from equipment inefficiencies and from thermodynamic limitations on equipment. Considering the internal combustion engine approximately 35% to 40% of heat energy is converted into useful mechanical work. The remaining heat from the engine is expelled into the atmosphere by exhaust gases and engine cooling systems [6]. It means approximately 60%-65 % energy losses as a waste heat through exhaust. Exhaust gases immediately leaving the engine can have temperatures as high as 842-1112°F [450-600°C]. Thus the high content of heat from the exhaust can easily be redirected and reused to provide useful work. [7].

Various Engine There Output S.N	Engine Type	Power Output (kW)	Waste Heat
1.	Small air cooled diesel engine	35	30-40 % of energy
2.	Water air cooled engine	35-150	30-40 % of energy
3.	Earth moving machineries	520-720	30-40 % of energy
4.	Marine applications	150-220	30-40 % of energy
5.	Trucks and road engines	220	30-40 % of energy

Table 2 – Waste Heat according to the Engine Type

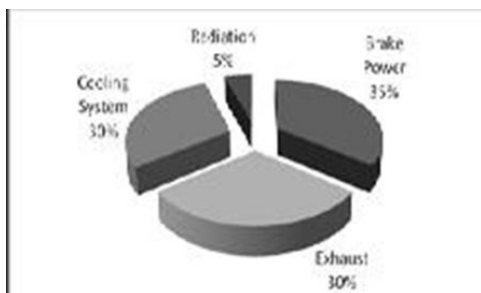

Fig 3 - Total percentage of waste energy in system

**POSSIBLE WAY OF USING HEAT RECOVERY SYSTEM**

The modern day vehicles run generally on IC engines, i.e. Internal Combustion engines. The majority of vehicles are still powered by either spark ignition (SI) or compression ignition (CI) engines. Small air-cooled diesel engines up to 35 kW output are used for irrigation purpose, small agricultural tractors and construction machines whereas large farms employ tractors of up to 150 kW output. Water or air-cooled engines are used for a range of 35-150 kW and unless strictly air cooled engine is required, water-cooled engines are preferred for higher power ranges. Earth moving machinery uses engines with an output of up to 520 kW or even higher, up to 740 kW. Trucks and road engines usually use high speed diesel engines with 220 kW output or more.

**REFRIGERANT USED FOR THE ABSORPTION REFRIGERATION SYSTEM**

The properties of the refrigerant combination are that, in liquid phase, they must have a margin of miscibility within the operating temperature range of the cycle. The mixture should also be chemically stable, non-toxic, and non-explosive. In addition to these requirements, the following are desirable [8-9]:

- a. Refrigerant should have high heat of vaporization and high concentration within the absorbent in order to maintain low circulation rate between the generator and the absorber per unit of the cooling capacity.
- b. Transport properties that influence heat and mass transfer, e.g., viscosity, thermal conductivity, and diffusion coefficient should be favorable.
- c. Both refrigerant and absorbent should be non-corrosive, environmental friendly, and economical. There are some 40 refrigerant compounds and 200 absorbent compounds available. However, the most common working fluids are water/ammonia and LiBr/water. Since the invention of absorption refrigeration systems, water/ammonia has been widely used for both cooling and heating purposes.

The main properties are:

- a. Ammonia (refrigerant) and water (absorbent) are highly stable for a wide range of operating temperature and pressure.
- b. It has highest refrigerating effect per Kg of refrigerant. The leakage of this refrigerant may be quickly & easily detected by the use of burning sulphur candle which in the presence of ammonia will form white fumes of ammonium sulphite. It is environmental friendly.

**METHODOLOGY**

Absorption refrigeration systems use a heat source instead of conventional means of power to provide the energy needed to produce cooling. In this system the use of condenser is omitted and an absorber is used instead of the condenser. The key processes in an absorption refrigeration system are the absorption and desorption of the refrigerant. A simple absorption system has five main components: the generator, the condenser, the evaporator, the absorber, and the solution heat exchanger

The Figure (4) shows the schematic diagram of the VARS with the flow of the refrigerant through the different components. In this system the NH<sub>3</sub> is used as a refrigerant and the water is used as an absorbent. The ammonia and



water combination is used in this system because of the following desirable qualities:

- $1\text{m}^3$  of water absorbs  $800\text{m}^3$  of ammonia ( $\text{NH}_3$ ).
- Latent heat of ammonia at  $-15^\circ\text{C} = 1314\text{ kJ/kg}$ .
- Critical temperature of  $\text{NH}_3 = 132.6^\circ\text{C}$ .
- Boiling point at atmospheric pressure =  $-33.3^\circ\text{C}$

In this system the low pressure ammonia vapor refrigerant leaving the evaporator enters the absorber, where it is absorbed by the water at lower temperature in the absorber. The water has an ability to absorb a very large quantity of ammonia vapor. The absorption of ammonia vapor in water lowers the pressure in the absorber which in turn draws more ammonia vapor from the evaporator and thus raises the temperature of the solution. Cooling arrangement is employed in the absorber to remove the heat of solution emitted, this is necessary to increase the absorption capacity of water, because the temperature of water is inversely proportional to the absorbing ability of water for ammonia vapor. This results in the formation of a strong solution in the absorber. This solution is then stored in the generator. The generator is the heating unit, where the heat is supplied to the ammonia solution. The generator requires the temperatures in the range of  $125^\circ\text{C}$  to  $170^\circ\text{C}$  with air cooled absorber/condenser and  $80^\circ\text{C}$  to  $120^\circ\text{C}$  when water-cooling is used in the system. In this case, the generator unit is placed near the exhaust pipe and the heat from the exhaust is utilized to raise the temperature of the mixture in the generator. During the heating process ammonia vapors are separated from the solution at high pressure and leaves behind the weak solution in the generator. The weak ammonia solution flows back to the absorber at low pressure. The high pressure ammonia vapor moves from the generator and is condensed in the condenser to high pressure forming liquid ammonia. The third fluid is used in the system to regulate the pressure. The  $\text{H}_2$  is the selected fluid due to its certain properties which flows from the absorber to the evaporator.

#### ADVANTAGES OF SYSTEM

The use of a Vapor Absorption Refrigeration System in the vehicles used on roads. Transport vehicles have the following advantages:

1. No refrigerant compressor is required.
2. No extra work is required for the working of the refrigerating unit
3. Reduction in capital cost.
4. Reduction in fuel cost.
5. Reduced atmospheric pollution.
6. Reduced maintenance.
7. Reduced noise pollution.

#### CONCLUSION

The possibility to design a refrigeration unit inside an automobile using the waste heat from the engine of the vehicle based on Vapor Absorption Refrigeration System is realistic. Also keeping in mind the Environmental safety view, this system is Eco-friendly as it involves the use of Ammonia (a natural gas) as a refrigerant and is not responsible for Green House effect and OZONE layer depletion. In this way we can conclude, that out of the total heat supplied to the engine in the form of fuel combustion, approximately, 35% to 40% is converted into useful mechanical work; the remaining heat is categorized under the waste heat and expelled out of the system, resulting in the rise of entropy, so it is required to utilize this waste heat

into useful work. Possible methods to recover the waste heat from internal combustion engine through the study on the performance and emissions of the internal combustion engine are discussed upon and can be designed. Waste heat recovery system is the best way to recover waste heat and saving the fuel.

#### REFERENCES

1. Ananthanarayanan P N 'Refrigeration & Air Conditioning', Tata McGraw-Hill.
2. Palm, B., 2008. Hydrocarbons as refrigerants in small heat pump and refrigeration systems – a review. *Int. J. Refrigeration* 31,552–563.
3. Corberan, J.M., Segurado, J., Colbourne, D., Gonzalez, J., 2008. Review of standards for the use of hydrocarbon refrigerants in a/c, heat pump and refrigeration equipment. *Int. J. Refrigeration* 31, 748–756.
4. Domanski, P.A., Yashar, D., 2006. Comparable performance evaluation of HC and HFC refrigerants in an optimized system. In: *Proceedings of the Seventh IIR-Gustav Lorentzen Conference on Natural Working Fluids at Trondheim, Norway, May 29–31.*
5. Horuz I (August 1999), 'Vapor Absorption Refrigeration in Road Transport Vehicles', *Journal of Energy Engg, Volume 125, Issue 2.*
6. P. Sathiamurthi, "Design and Development of Waste Heat Recovery System for air Conditioning," Unit European Journal of Scientific Research, Vol.54 No.1 (2011), pp.102-110, 2011.
7. S. Karellasa, A.-D. Leontaritsa, G. Panousisa, E. Bellos A, E. Kakaras, "Energetic And Exergetic Analysis Of Waste Heat Recovery Systems In The Cement Industry," *Proceedings of ECOS 2012 – The 25th International Conference On Efficiency, Cost, Optimization, Simulation And Environmental Impact Of Energy Systems June 26-29, 2012, Perugia, Italy.*
8. *Khurmi R S, Gupta J K, Refrigeration and Air Conditioning- 2010, Vapour Absorption Refrigeration (Pg 238-249).*
9. Yunus A.Cengel and Michael A. Boles. *Thermodynamics An Engineering Approach.* Tata McGraw-Hill,2003. For lit 6. Horuz I (August 1999), 'Vapor Absorption Refrigeration in Road Transport Vehicles', *Journal of Energy Engg., Volume 125, Issue 2.*