

DESIGN AND FABRICATION OF BANDING AND SEEDING MACHINE

N SANKAR^[1], R BALAKRISHNAN^[2], L V DHEERAJ^[3], S JAGAN^[4], B VISHNU^[5]

[1] Assistant Professor, Department of Mechanical Engineering, Sri Sai Ram Engineering college(Anna University), West Tambaram, Chennai-600 044.

[2] B.E.-Mechanical Engineering, Sri Sai Ram Engineering college(Anna University), West Tambaram, Chennai-600 044.

[3] B.E.-Mechanical Engineering, Sri Sai Ram Engineering college(Anna University), West Tambaram, Chennai-600 044.

[4] B.E.-Mechanical Engineering, Sri Sai Ram Engineering college(Anna University), West Tambaram, Chennai-600 044.

[5] B.E.-Mechanical Engineering, Sri Sai Ram Engineering college(Anna University), West Tambaram, Chennai-600 044.

ABSTRACT— Machines are designed for improving the productivity as well as performance. Now a day's world is moving towards rapid growth of all sectors including the agricultural sector. Agriculture is vital source of income of India. About 65-70 % of Indian population depends upon agriculture. So for fulfilling the future demands there is need of advancement in techniques and equipment's of farming at economic cost because in India every farmer can't afford tractor and other high cost sowing equipments. Seed sowing and fertilizer placement is the main activity in farming. This project is based on enhancement of farming process. This machine is made up to accomplish task first one is seed sowing and another task is fertilizer spraying. Both of these mechanism work at the same time. The main objective of these operation are to place the seed as well as fertilizer at proper place and seeds at proper distance from each other with appropriate soil compaction. Increase in population demand also increases to meet the requirement of new techniques of cropping have to be implemented in farming sector. The basic requirements of seed sowing machine are it should be simple in design and construction affordable at low cost for farmers. Easy to handle and repair by farmers. In today's era availability of labour is becoming great concern. This machine does the work with less effort and

in less time so it reduces cost of labour required for seed sowing and fertilizer placement. The main scope of this project is to reduce the cost of machine and get optimum yield.

Keywords— Seed sowing machine, Agriculture sector.

I. INTRODUCTION

The major occupation of the Indian rural people is agriculture and both men and women are equally involved in the process. Agriculture has been the backbone of the Indian economy and it will continue to remain so for a long time. It has to support almost 17% of world population from 2.3% of world geographical area and 4.2% of world's water resources. The present cropping intensity of 137% has registered an increase of only 26% since 1950-51. The basic objective of sowing operation is to put the seed and fertilizer in rows at desired depth and spacing, cover the seeds with soil and provide proper compaction over the seed. This paper is for designing such machine which should fulfill above requirements with relatively saving of time and labour.

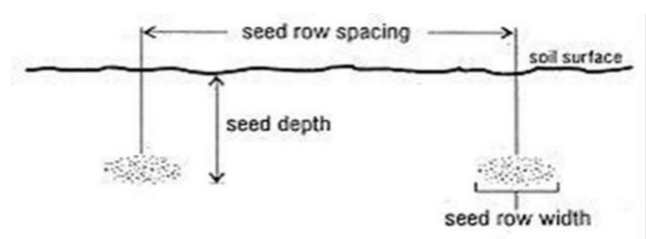

Fig.1 PARAMETERS INVOLVED IN SEEDING

I. LITERATURE SURVEY

Roshan V Marode, Gajanan P Tayade[2013] focused on the seed feed rate is more but the time required for the total operation is more and the total cost is increased due to labour, hiring of equipment. The conventional seed sowing machine is less efficient, time consuming. Today's era is marching towards the rapid growth of all sectors including the agricultural sector. To meet the future food demands, the farmers have to implement the new techniques which will not affect the soil texture but will increase the overall crop production. Agriculture in India has a significant history. Today, India ranks second worldwide in farm output. Still, agriculture is demographically the broadest economic sector and plays a significant role in the overall socio-economic fabric of India. This paper deals with the various sowing methods used in India for seed sowing and fertilizer placement. The comparison between the traditional sowing method and the new proposed machine which can perform a number of simultaneous operations, has number of advantages.

Conclusion: This paper gives types sowing machine. The following are the three different types of seed sowing are broadcasting: The field is then seeded by throwing the seeds over the field, a method known as manual broadcasting. The result was a field planted roughly in rows, but having a large number of plants. When the seeds are scattered randomly with the help of hand on the soil, the method is called broadcasting. Dribbling: Drill sowing and dribbling (making small holes in the ground for seeds) are better method of sowing the seeds. Once the seeds are put in the holes, they are then covered with the soil. Comparing the different traditional seed sowing methods with the proposed machine and considering its limitations, it is concluded that,

- 1) Seed and fertilizer flow rate can be controlled.
- 2) Row spacing and seed spacing process can be achieved.
- 3) Seed and fertilizer utilization can be done in proper manner with minimum loss.

III. PREVIOUS METHOD

A. BROADCASTING

Broadcasting is otherwise called as random sowing literally means "scattering the seeds". Broadcasting is done for many crops. Broadcasting is mainly followed for small size to medium size crops. This is the largest method of sowing followed in India, since agriculture was started. It is the easiest and the cheapest method of sowing and requires minimum labours. To have optimum plant population in unit area certain rules are followed that is only a skilled person should broadcast the seeds for uniform scattering and the ploughed field should be in a perfect condition to trigger germination.

B. DIBBLING

This is actually line sowing. Inserting a seed through a hole at a desired depth and covering the hole. Dibbling is practiced on plain surface and ridges and furrows or beds and channels. This type of sowing is practiced only under suitable soil condition. Rice fallow cotton is dibbled on a plain surface. The seeds are dibbled at 2/3rd from the top or 1/3rd at bottom of the ridge. Before sowing, furrows are opened and fertilizers are applied above which seeds are sown. The seeds do not have contact with the fertilizers. This is done for wider spaced crops and medium to large sized seeds. Ex. Sorghum, maize, sunflower, cotton are dibbled on ridges and furrows.

C. SEED DRILLING

Drilling is the dropping of seeds in a definite depth covered with soil land compacted. In this method, sowing implements are used for placing the seeds into the soil. Both animal drawn gourmand power operated (seed drill) implements are available. Seeds are drilled continuously or at regular intervals in rows. In this method, depth of sowing can be maintained and fertilizer can also be applied simultaneously. It is possible to take up sowing of inter crops also. It requires more time, energy and cost, but maintains uniform population per unit area. Seeds are placed at uniform depth, covered and compacted.

D. TRANSPLANTING

This method of planting has two components, namely Nursery bed and Transplanting. In nursery, young seedlings are protected more effectively in a short period and in a smaller area. After the growth of the seedlings it is transplanted to the main field which is very laborious and expensive method.

E. SOWING BEHIND THE PLOUGH

Sowing behind the plough is done by manual or mechanical means. Seeds are dropped in the furrows opened by the plough and the same is closed or covered when the next furrow is opened. The seeds are sown at uniform distance. Manual method is a laborious and time consuming process. Seeds like red gram, cowpea and groundnut are usually to be sown behind by the country plough.

IV. NEED FOR NEW METHOD

Due to these reasons, the design and development of "Seed sowing machine" has been taken up. Taken care to ensure that the cost of the machine, operational cost and maintenance cost are low. Also to reduce the weight of the machinery to increase the productivity of crop. Various health problems can be minimized. This product is easy to use and less effort required as compared. It is helpful for small scaling farming.

In this survey, we dealt on various methods to approach our idea and also studied about relevance to various engineering solutions. The survey reviles various efficient and alternative methods in order to start upon our idea.

The move from a conventional to a direct seeding system influences four important crop growth factors:

- access to nutrients
- competition with weeds
- access to available moisture
- use of sunlight

Row spacing is the distance from the centre of one seed outlet to the centre of the fertilizer outlet. Row spacing is related to nutrient placement, weed competition and sunlight. Seeding rate is primarily related to weed competition and available moisture. As a result, row spacing is usually changes and seeding rates sometimes change with move to direct seeding.

V. DESIGN CALCULATION

DESIGN OF SHAFT

The shaft is subjected to 20 kg of load.

$$W = 20 \text{ Kg}$$

$$F = 300 \text{ N}$$

$$L = \text{length of the shaft} = 752 \text{ mm}$$

$$\text{Radius of shaft} = 7.5 \text{ mm}$$

Bending Moment is given by,

$$M = \frac{W \times L}{4}$$

$$M = 20 \times 9.81 \times 752 / 4$$

$$M = 36885.6 \text{ N-mm}$$

Twisting Moment is given by $T = FR$

$$T = 300 \times 7.5$$

$$T = 2250 \text{ N-mm}$$

Permissible stress is given by Applying from Design data book,

$$\text{Ultimate tensile stress} = U = 770 \text{ N/mm}^2$$

$$\sigma_{\text{per}} = 0.18 \times 0.75 \times U$$

$$\sigma_{\text{per}} = 103.95 \text{ N/mm}^2$$

From Design data book for Shaft design is given

$$\text{by, } \left(\frac{1}{16} \right) \times 3 \times \sigma_{\text{per}} = \sqrt{(K_b M)^2 + (K_t T)^2}$$

Where,

$$\text{Shock Factor in bending} = K_b = 1.5$$

$$\text{Shock Factor in torsion} = K_t = 1.2$$

$$\left(\frac{1}{16} \right) \times 3 \times \sigma_{\text{per}} = \sqrt{(K_b M)^2 + (K_t T)^2}$$

$$\left(\frac{1}{16} \right) \times 3 \times 103.95 = \sqrt{(1.5 \times 36885.6)^2 + (1.2 \times 2250)^2}$$

$$d = 13.9 \text{ mm}$$

This is ideal diameter of shaft which is needed. Since a shaft may be subjected to extra load as it has to work in rough conditions and from availability point of view, we chose a safe diameter of 15 mm. Thus diameter of shaft, $d = 15 \text{ mm}$.

Bending Stresses is given by

$$\text{Bending moment} = \text{Moment of}$$

$$\text{resistance } (M / I) = (\sigma / y)$$

Where,

$$\text{Polar Moment of Inertia} = \frac{\pi}{32} \times d^4$$

$$= 4970.097 \text{ mm}^4$$

Distance from Natural Axis is given by,

$$y = \frac{d}{2}$$

$$y = 7.5 \text{ mm}$$

Bending moment = Moment of

$$\text{resistance } 36885.6 / 4970.097 = 7.5$$

$$B_{\text{induced}} = 55.66 \text{ N/mm}^2$$

Failure stress is given by,

$$\text{Failure stress} = B_{\text{steel}} / \text{F.O.S} \text{ Where,}$$

$$B_{\text{steel}} = 360 \text{ N/mm}^2$$

$$\text{F.O.S} = 3$$

$$\text{Failure Stress} = 360/3$$

$$\text{Failure stress} = 120 \text{ N/mm}^2$$

as,

$$B_{\text{steel}} > B_{\text{induced}}$$

Thus Design of shaft is safe.

DESIGN OF CHAIN SPROCKET

Height of setup is taken by considering the average height of normal person and aesthetic considerations. The diameter of wheel = 200 mm.

Now for one revolution of wheel, setup will move forward linearly of distance = $\pi D = 3.1416 * 200$

$$\text{Linear distance} = 628.32 \text{ mm.}$$

According to conventional pattern of seed sowing. Assumption is taken that the distance between two consecutive seeds is approximately 110 mm.

Now for one revolution of wheels minimum 6 seeds must be sown.

So we take the chain drive of ratio 1:1.

Taking the Diameter of Lower sprocket = 60 mm

Diameter of upper sprocket = 60 mm

Finally after one rotation of wheel, there is two revolutions of upper sprocket so six seeds sown in field.

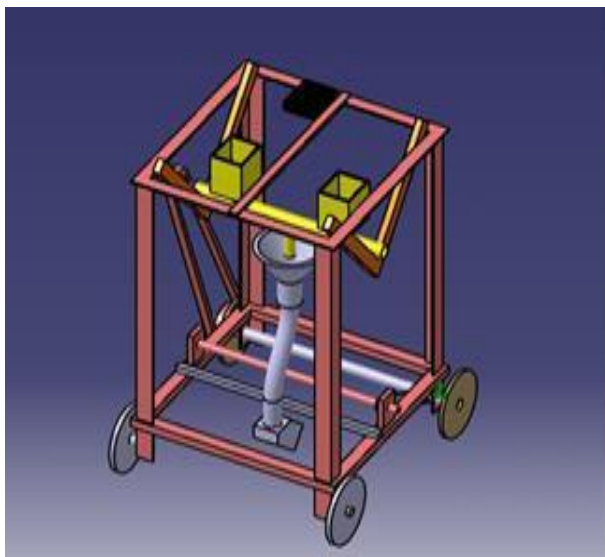

Fig.2 3D MODEL

VI. CONCLUSION

The design was fabricated and tested successfully. The following are the conclusions drawn, required distance between seeds and fertilizers at desired depth. It operates with less effort. Seed sowing equipment's has remarkable influence in agriculture. By using this project of seed sowing equipment we can save more time required for sowing process and also it reduces lot of labour cost. It is very helpful for small scale farmers as it weighs less. After comparing the different method of seed sowing it is concluded the seed sowing machine can maintain row spacing and controls seed rate, we would like to present it before this prosperous world.

REFERENCES

- [1] D. Ramesh, H. P. Girishkumar, July 2014 "Agriculture Seed Sowing Equipments: A Review", ISSN NO.: 2278-7798, Volume:3.
- [2] A. Kannan, K. Esakkiraja, S. Thimmarayan, January 2014 "Design and Modification of Multipurpose Sowing Machine", Volume:2, ISSN (ONLINE):2321-3051.
- [3] D. Ramesh, H.P. Girishkumar, "development of Agriculture Seeding equipment", International Journal of Informative & Futuristic Research, ISSN (Online): 2347-1697 Volume-1 Issue-10, June 2014.
- [4] A. kawadaskar, Dr. S.S. Chaudhari, "Review of method of seed sowing and concept of multi-purpose seed sowing machine", International journal of Pune & Applied Research in Engineering & Technology, ISSN: 2319-507X, volume 1(8):267-276.
- [5] Roshnan V. Marode, P. Gajanan, and K. Swapnil, October 2013 "Design & Implementation of Multiseed Sowing Machine", Volume: 2, NO. 4, ISSN NO.: 2278-0149, Planted.
- [6] A. Rohokale, 2004 "International Journal of Advanced Agriculture System with Proper Seed Spraying". Volume: 3.
- [7] B. Shivprasad, M. Ravishankara, B. Shoba, 2010 "Design and Implementation of Seeding and Fertilizing Agriculture Robot", Volume:1(3)190-213.