

A Study on Hybrid Energy System Comprising of PV, Wind and Hydrogen Cell for Grid Connected System

Aditya Saluja, Anil Kumar
Scholar, Assistant Professor,
Department of Electrical Engineering,
DCRUST, Murthal, India

Abstract : The paper deals with the hybrid generating system comprising of wind, PV& fuel cell synchronized to the grid system. Now a day's world relies on fossil fuels for their energy demand. These fossil fuels are going to exhaust soon and will lead to energy crises for the world. Also they cause various environmental problems for the planet.

Hence the need of non-conventional resources with good technology at lower cost is the utmost requirement of today's generation. Renewable energy systems especially dealing with PV, Wind and Fuel cell are in research with past few years. MATLAB stimulations provide verified and effective results of the proposed models.

IndexTerms - Wind energy, PV, fuel cell, hybrid system, Grid synchronized, MATLAB modeling

1. INTRODUCTION

A fast reduction of the fossil fuels worldwide has created an alarming condition for the energy requirement of tomorrow. The alternate energy resources taken into consideration like solar, wind, hydro are clean i.e. environment friendly and of great potential. PV power can be easily harnessed in the countries with good amount of sunny days. [1] The non-renewable energy resources provide a continuous and stable power to the grid whereas considering the climatic conditions there may be variations in the generation by PV, Wind and hybrid of both, which may cause problems like extreme frequency variation to the grid. For attaining the reliability of a system it is required to associate it with some other power source for getting continuous power generation. A convenient solution to this problem can be attained by using fuel cells in combination with the system [2]. PEMFCs are an electrochemical arrangement that converts chemical energy straight into electrical energy with a very high efficiency. While hydrogen is hauling out from water by using surplus electricity obtained from the renewable energy resources, it can be considered as an eco-friendly fuel. Usage of such energy sources can reduce the emission of CO₂ to almost zero [3]. In this paper we are combining the PEMFCs with the combination of PV and wind in order to attain a reliable system for grid Synchronization. The combination of three provides a system with good efficiency, proper response time and flexibility.

2. WIND ENERGY

Wind energy hitch the energy from motion of wind and converts it into electrical power. The formation of wind takes place due to change in temperature in the atmosphere. The wind is created by movement of air, as the warm air raises up the cold air takes its place and these movement results in formation of wind. The windmill harnesses energy from the moving air and produces mechanical power as torque which is then used for pumping of water or grinding of seeds, but now a day these windmills are modified to generate electrical power by attaching electrical generator to moving shaft. The kinematic energy of the breeze is converted into electrical energy and these modern modified windmills are called are called wind turbines. The advances in understanding the furling has resulted in being incorporated in the wind turbines. [4]

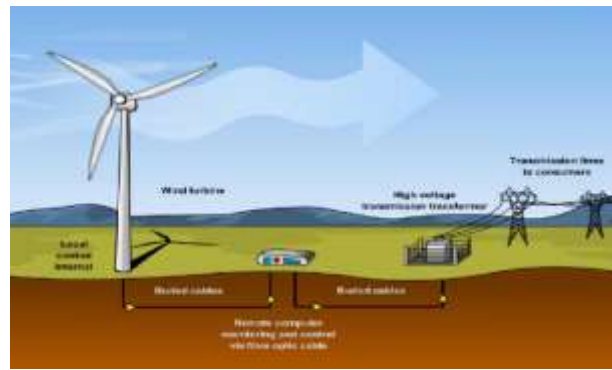

Figure 1: Block diagram of wind generating system

Although wind turbine technology appears simple but there are many mechanical complication in modern wind turbine. Wind rotates turbine’s blade around a central hub, which turns a gearbox shaft at low speed, this in turn rotates a high speed generator in order to produce electricity. Hence the generator converts kinetic energy into electrical energy which is carries via cables to electrical sub stations for distribution.

The Wind power is measured in watts, it is determined by the size of rotor blades the wind velocity and the density of air. Theoretically the power in moving air is proportional to rate of flow of kinetic energy per second through a wind turbine. The equation of wind power is given by

$$P = 0.5 \times \rho \times A \times V^3 \times C_p \text{ (Watts)} \tag{1}$$

Where

P = Wind power (watts)

ρ (rho) = Air density (kg/m³)

A = circular region in (m²) swept by rotors

V = air velocity in m/s or mph

C_p = power coefficient efficiency (0.35-0.45%)

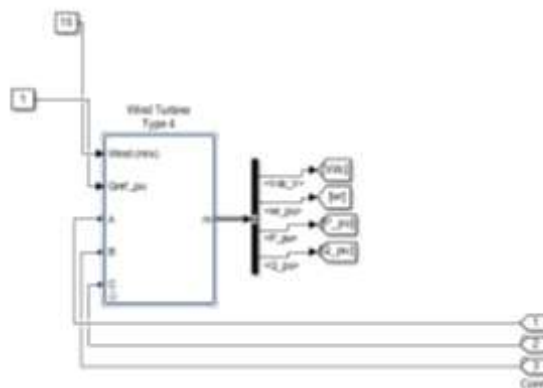

Figure 2: Model of Wind Energy System

The mathematical equations of above model are demonstrated using MATLAB as Simulink model shown in figure 2. The system is designed for 5 KW and the output profile of the system is as shown in figure 3.

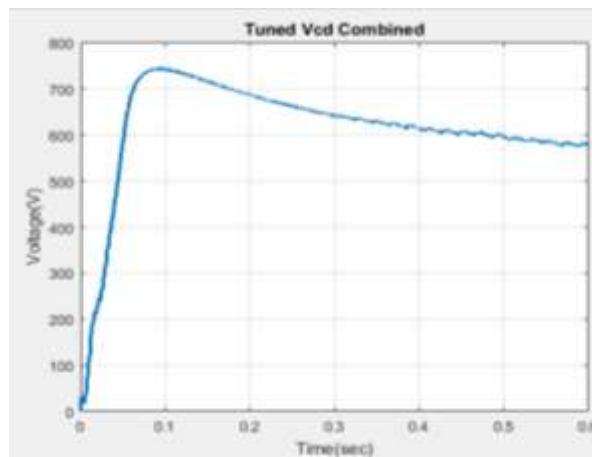

Figure 3: Output of Wind Energy System

2.2 PV ENERGY SYSTEM

PV cells are semi-conductor device used in the conversion of solar energy into electrical energy directly. Most of the PV cells produced today are made up of crystalline silicon as a semiconductor material. A typical PV cell has an efficiency of about 15 % that means it converts 1/6 of the solar energy into electricity. PV cells have life expectancy of about 30 years and are made up of silicon which is a non-toxic material. They require minimal maintenance and can be almost completely recycled.



Figure 4: PV cells

According to quantum physics light has a dual character i.e. it is a particle as well as wave. The elements of the light are termed photons that are mass less and move with the speed of light. The energy of a photon can be considered by the Einstein’s rule given by:

$$E=HV \tag{2}$$

Where:

E= Photons energy

H= Plank’s constant ($6.626 \times 10^{-34} \text{Js}$)

V = Frequency of the photon

In the metals electrons exists as valance and free electron. The order for a valance electron to become a free electron it must be supplied with an energy that which is more than or equal to the binding energy. In Photo electric effects the electrons acquire this energy by their collision with photons. The free electrons so obtained are called photo electrons. The energy required to release these valance electrons is called “workout” and lasting energy is altered into kinetic energy of the free electrons.

$$HV = w_i + e_{Kin} \tag{3}$$

Where-

HV= Energy of the photons

w_i = Work out

e_{Kin} = Emitted electron kinetic energy

The effectiveness of PV solar cell is termed as percentage of electric power output to the solar radiation power. Mathematically it can be written as:

$$\eta = \frac{P^*_{el}}{p_{sol}} = \frac{u \cdot i}{e \cdot a} \tag{4}$$

Where:

P^*_{el} = Electric power output

p_{sol} = Radiation power

u = Value of output voltage

i = Value of electricity output

e = Precise radiation power

a = Region

These equations are modeled using MATLAB as Simulink model shown in figure 5 and the corresponding output graphs are shown in figure 6. . The system is designed for 5 KW

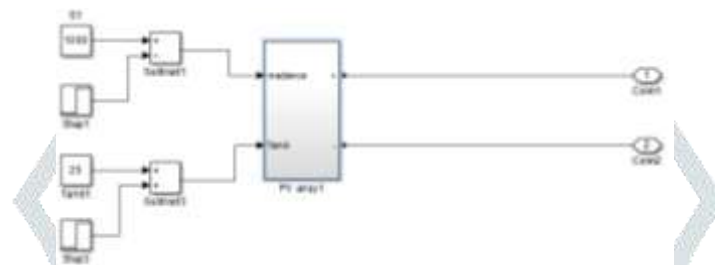

Figure 5: Simulink model of PV Energy System

3. FUEL CELL

It was early developed in 1839 by Welsh lawyer Sir William Robert Grove. The operations of the fuel cells are same. They behave like batteries but they do not need recharging this makes this cell very effective and efficient. Fuel cells work like batteries but need not to get re-energized. They produced heat and electricity as an output as long as fuel is supplied. It consists of an anode and cathode sandwiched around an electrolyte. In this system hydrogen is fed from anode and air is fed from cathode side. The electrons go through an external circuit which causes the flow of the electricity.

It is one of the most promising technologies which operate best on pure hydrogen. It also works on another fuel like natural gas, methanol and gasoline. There are very restricted studies on sustainable aspects of hydrogen energy system including fuel cells commenced by several researches [5-8]. The system is designed for 6 KW.

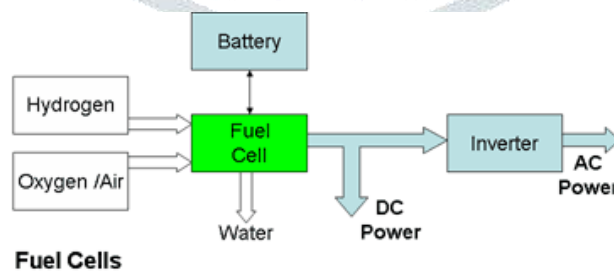

Figure6: Block diagram of Fuel Cell

The proton migrates through an electrolyte to the cathode, where they reunite with the oxygen and the electrons to produce water and the heat.

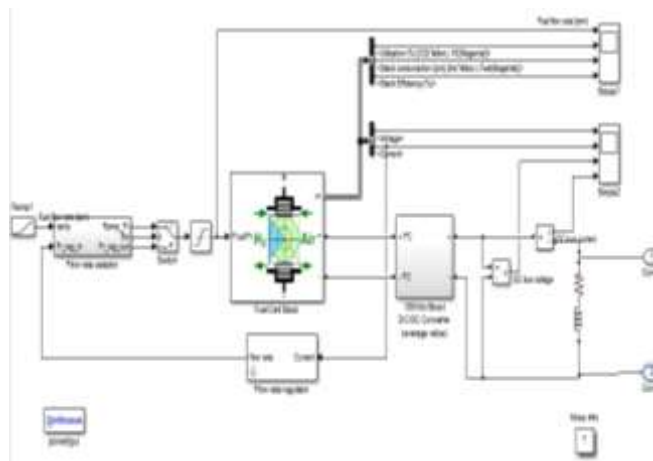

Figure 7: Simulink model of PEM fuel cells.

Preset model: **PEMFC - 6 kW - 45 Vdc**

Model detail Level: **Detailed**

Voltage at 0A and 1A [V_0(V), V_1(V)] [65 63]

Nominal operating point [Inom(A), Vnom(V)] [133.3 45]

Maximum operating point [Iend(A), Vend(V)] [225 37]

Number of cells 65

Nominal stack efficiency (%) 55

Operating temperature (Celsius) 65

Nominal Air flow rate (lpm) 300

Nominal supply pressure [Fuel (bar), Air (bar)] [1.5 1]

Nominal composition (%) [H2 O2 H2O(Air)] [99.95 21 1]

Figure 7: block parameters- fuel cell stack

Fuel cell nominal parameters:

Stack Power:

- Nominal = 5098.5 W
- Maximal = 8525 W

Fuel Cell Resistance = 0.07833 ohms

Nerst voltage of one cell [E_n] = 1.1288 V

Nominal Utilization:

- Hydrogen (H₂)= 99.95 %
- Oxidant (O₂)= 21 %

Nominal Consumption:

- Fuel = 60.38 slpm
- Air = 143.7 slpm

Exchange current [i₀] = 0.20197 A

Exchange coefficient [alpha] = 0.60845

Fuel cell signal variation parameters:

- Fuel composition [x_H2] = 99.95 %
- Oxidant composition [y_O2] = 21 %
- Fuel flow rate [FuelF] at nominal Hydrogen utilization:
 - Nominal = 50.06 lpm
 - Maximum = 84.5 lpm
- Air flow rate [AirF] at nominal Oxidant utilization:
 - Nominal = 300 lpm
 - Maximum = 506.4 lpm
- System Temperature [T] = 338 Kelvin
- Fuel supply pressure [PFuel] = 1.5 bar
- Air supply pressure [PAir] = 1 bar

Figure 8: fuel cell parameters

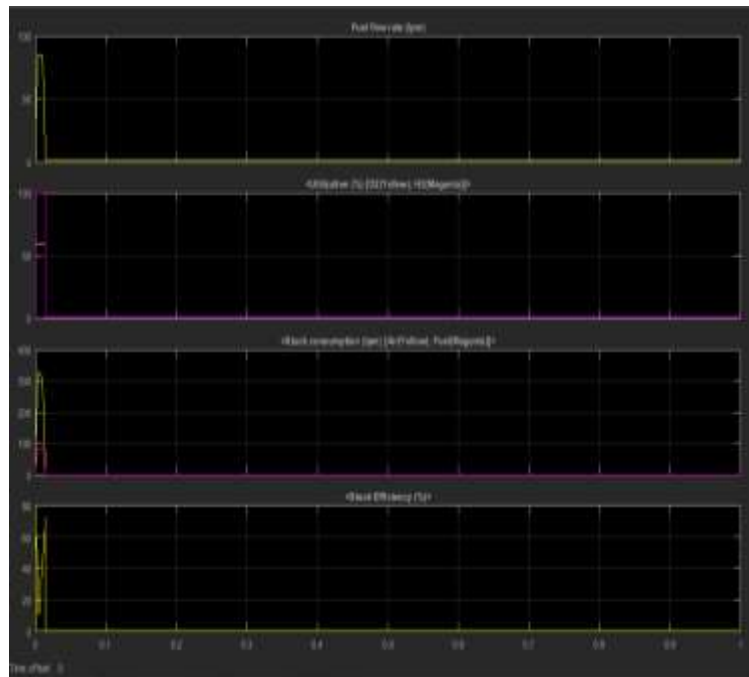

Figure 9: Output of PEM fuel cells.

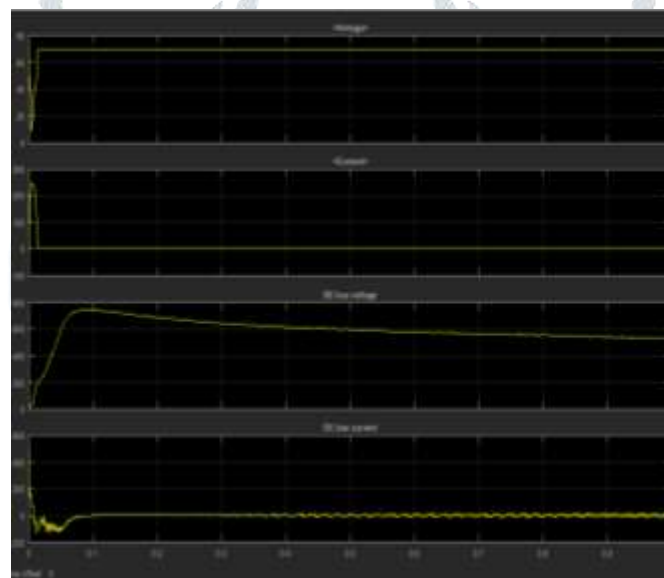

Figure 10: Output of PEMFCs in terms of voltage and current.

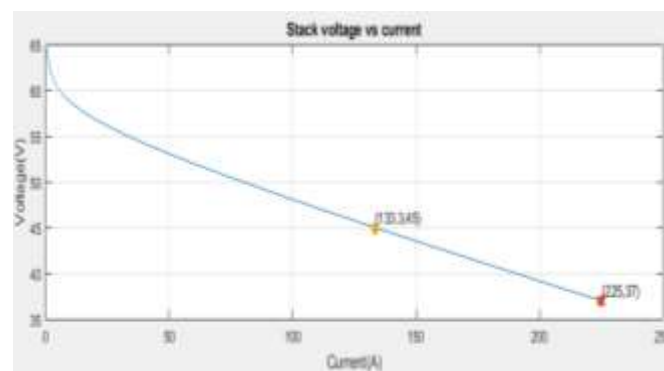

Figure 11: stack voltage vs. current

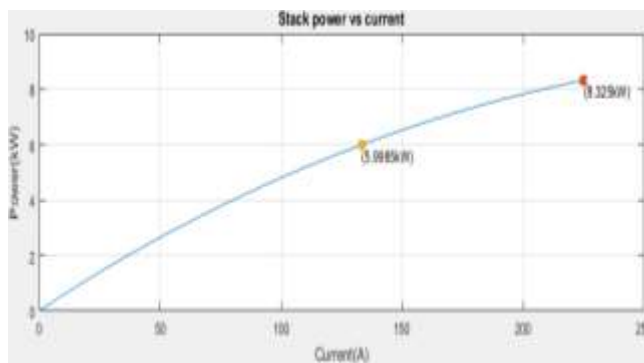

Figure 12: stack power vs. current

Proton Exchange Membrane (PEM)

1. Proton-exchange membrane fuel cells (PEMFCs) are expected to be the most accomplished type of fuel cell
2. They operate at lower temperature; they are lighter in weight and more compact which makes it ideal cell.
3. They operate about 40 to 50% efficiency and also can vary the output to match the demands.

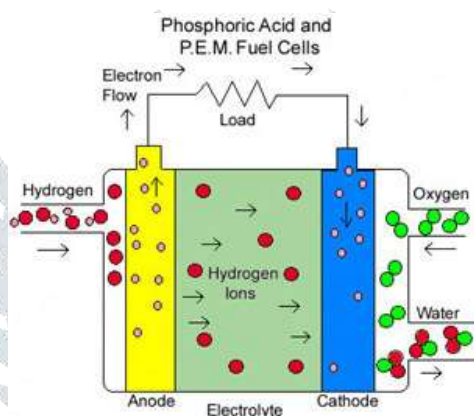

Figure 13: PEM fuel cells operate.

3.1 Controlling techniques used to synchronize the hybrid system with grid

The combination of PID and PSO is implemented in synchronizing the system with grid. The PSO is used to compute the values of PID controller. The table1 shows the value of PID used in the system synchronization.

Table 1: PID controller values

Perimeter	Value
P	-0.9
I	0.15
D	0

3.2 PID Proportional-Integral-derivative

“The controllers have diverse structures. Numerous methodologies are implemented for designing the controller in order to attain preferred performance level, but most dominant among them is (PID) type controller. Mathematical expressions for a PID controller are as”:

$$u(t) = K_p [e(t) + \tau_d \frac{de(t)}{dt} + \frac{1}{\tau_i} \int_0^t e(\tau) d\tau] \tag{5}$$

The TF of the controller is defined below:

$$C(s) = K_p \left[1 + \tau_d s + \frac{1}{\tau_i s} \right] \tag{6}$$

Terms of the controller are defined as:

- K_p = Proportional gain
- τ_d = Derivative time, and
- τ_i = Integral time.

3.3 Particle Swarm Optimization (PSO)

The PSO is a computational process that enriches a problem by iteratively trying to develop a solution with concern to a given measure of quality.

I. Hybrid system implementing wind, PV & Fuel cell

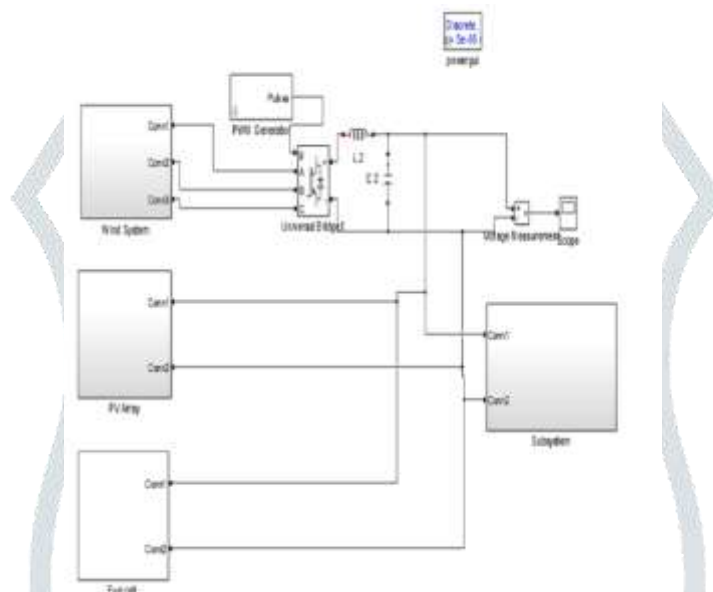

Figure 14: Hybrid system implementing wind, PV & Fuel cell

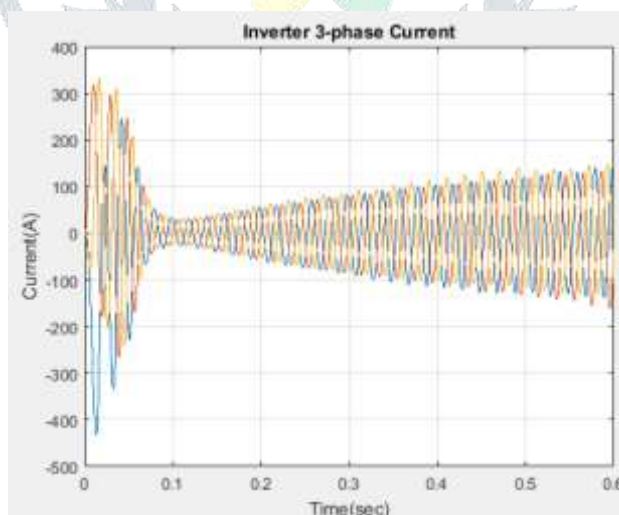

Figure 15: Inverter 3 phase current

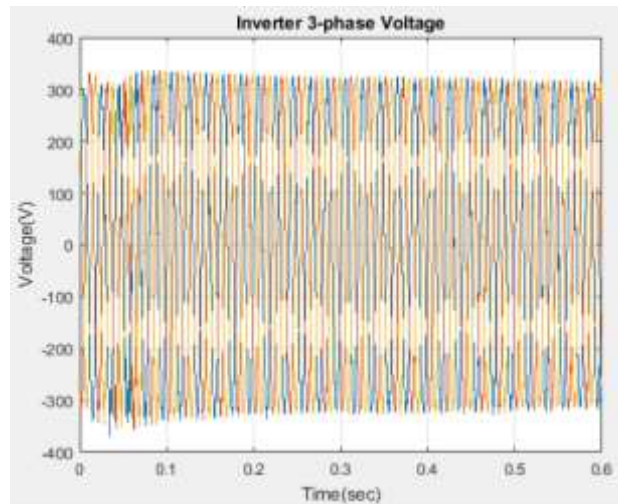

Figure 16: Inverter 3 phase voltage

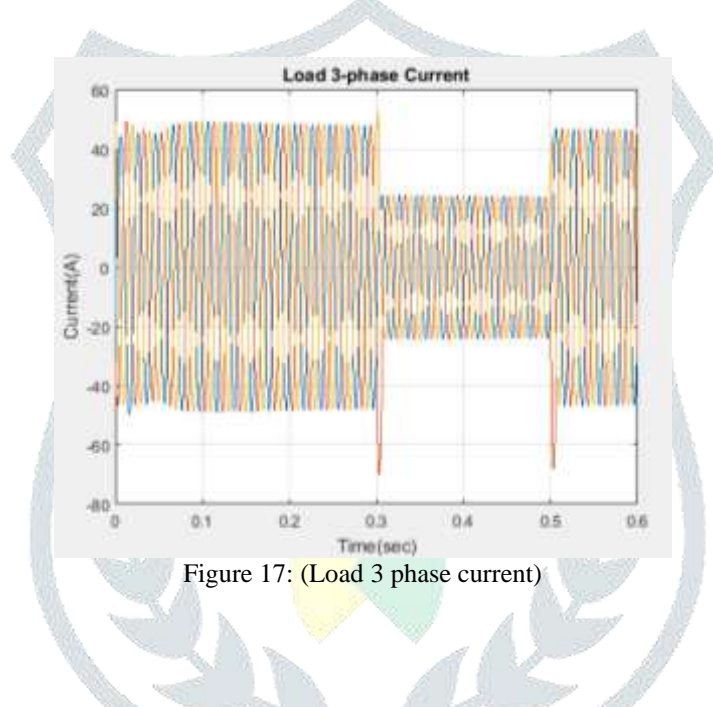

Figure 17: (Load 3 phase current)

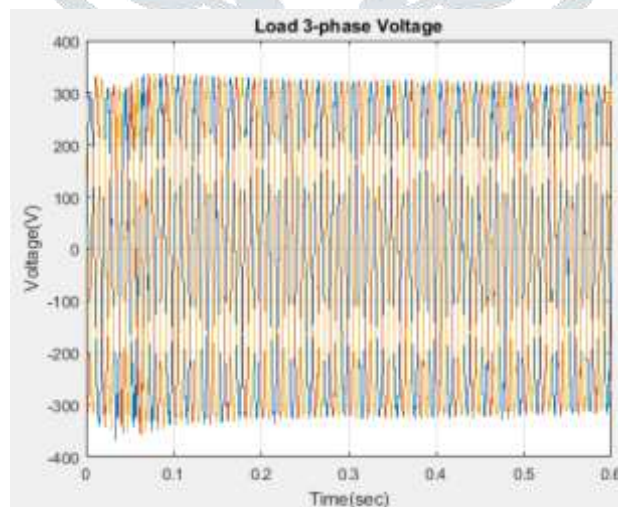

Figure 18: (Load 3 phase voltage)

4. CONCLUSION

The PV-wind-Fuel cell hybrid system is successfully implemented and the V_{dc} is tuned using PSO-PID controller. The gating pulse is generated using current hysteresis control and its voltage and current gets synchronized with GRID using PLL (phase locked loop). The renewable source is getting consumed first as per demand and then the lasting power is delivered by the grid to the load.

REFERENCES

Journal Articles:

- [1] B. S. Borowy and Z. M. Salameh, "Optimum Photo-voltaic Array Size for a Hybrid Wind/PV System," IEEE Transactions on Energy Conversion, Vol. 9, No. 3, 1994, pp. 482-488. doi:10.1109/60.326466.4
- [2] K. Agbossou, M. Kolhe, J. Hamelin, T. K. Bose, "Performance of a stand-alone renewable energy system based on energy storage as hydrogen", IEEE Transactions on Energy Conversion", Vol. 19, No. 3, pp. 633-640. 2004
- [3] Maleki, Akbar, and Alireza Askarzadeh. "Artificial bee swarm optimization for optimum sizing of a stand-alone PV/WT/FC hybrid system considering LPSP concept." Solar Energy 107 (2014): 227-235.
- [4] Davis, Dean A; Hansen, A. Craig; and Laino, David J.(2003). "Estimates the maximum design loads for a whisper H40 using Etrapolation methods." Proceedings of the wind power 2003 Conference, 18-21 May, 2003, Austin, TX, Washington D.C. American Wind Energy Association; session 4C.
- [5] Hart, D. "Sustainable energy conversion: fuel cells-the competitive options". Journal of Power Sources, Vol. 86, 2000, 23-27.
- [6] Pehnt, M. "Assessing future energy and transport systems: the case of fuel cells. Part I: methodological aspects". International Journal of Life Cycle Assessment, Vol. 8, No.5, 2003, 283-289.
- [7] Baretto, L., Makihira, A., and Riahi, K. "The hydrogen economy in the 21st century: a sustainable development scenario". International Journal of Hydrogen Energy, Vol. 28, 2003, 267-284.
- [8] Hopwood, B. Mellor, M. and O'Brien, G. "Sustainable development: mapping different approaches". Sustainable Development, Vol. 13, 2005, 38-52.

