

Bus Detection Module For Blind People

K.Bhavana¹ B.Lalitha² k.lalitha³

^{1,2,3}Prasad V Potluri Siddhartha Institute Of Technology, Kanuru,Vijayawada, Andhra Pradesh, India

Approved by AICTE and Affiliated to JNTUK: Kakinada

^{1,2,3}Department of electrical and electronics

Abstract--This project will shed the light on the field of transportation to improve the life quality of visually impaired persons (VIPs) using Radio Frequency module. The Idea behind this project is to develop a prototype that would use the technological advancements to assist the daily commuters, especially visual impaired person to access public transport.

This system will allow blind people to safely catch buses and other transportation with the help of vibrating device, alarm and a tactile interface through a wireless communication system between the transmitter and the receiver..

VIPs will have the opportunity to get information about bus arrival and departure time as well as assist the bus operator to know the presence of a VIP on the road. The motivation behind this project is that buses are vital in enabling blind people to participate fully in society, access to facilities and services.

Index Terms - INTRODUCTION

This project will shed the light on the field of transportation for the improvement of the life quality for visually impaired persons (VIP's) using the technology like radio frequency module. The idea behind this project is to develop a prototype that would use the technological advancements to assist the daily commuters, especially visual impaired person to access public transport.

This system will allow blind people to safely catch buses with the help of vibrating device, alarm and a tactile interface through a wireless communication system between the transmitter and the receiver. VIP's will have the opportunity to get information about bus arrival and departure time as well as assist the bus operator to know the presence of a VIP on the road. The system is based on a distributed model.

This system can be installed over the taxis, trains, public buses, etc... all over the city so that people can very easily communicate with them. This system, if manufactured commercially, is very economic and thus can be made available at the stores so that women, children, senior citizens or any section of society can use it. With few changes in the hardware and programming, this prototype can be turned into a security device. Looking towards the present scenario of the nation, this device can be proved to be very useful, as far as women

security is concerned. Thus, this project presents a new approach to bus identification system for VIP's using RF.

HARD WARE COMPONENTS

2.1 GENERAL BLOCK DIAGRAM:

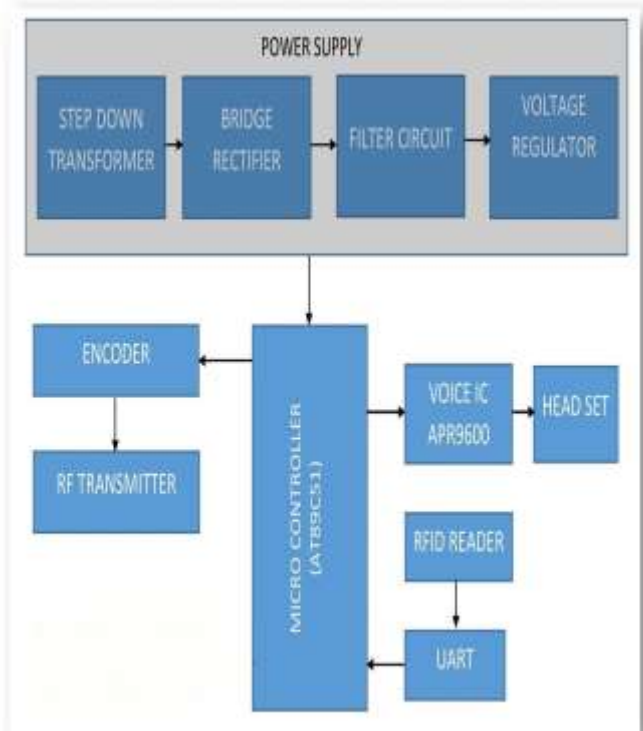

Fig 2.1 Functional Block Diagram of Blind Unit

2.2. DESCRIPTION OF COMPONENTS:

2.2.1. POWER SUPPLY:

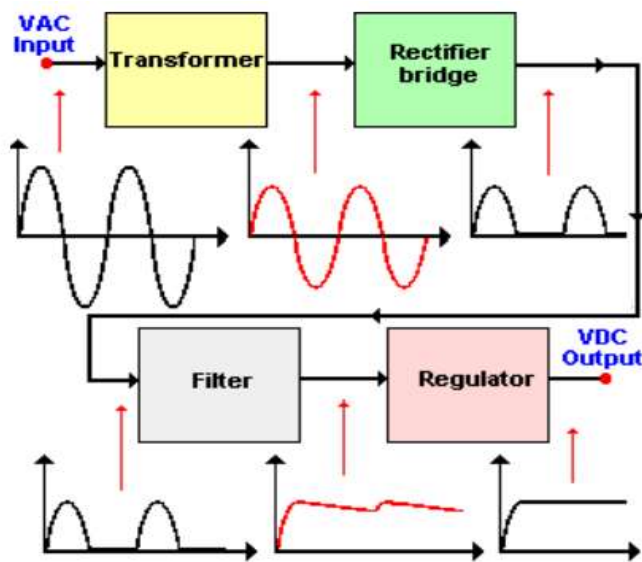

Fig 2.2 Block Diagram of Power Supply

Many electronic circuits need a direct current (DC) voltage source, but what we commonly find voltage sources of alternating current (AC). In order to achieve a direct current voltage source, the alternating current input must follow a conversion process like the one shown in the fig 2.2 which shows the operation of a voltage power supply using a block diagram and the waveforms at the beginning (AC input), at the end (DC output) and between each of the blocks. The input signal which goes to the primary of the transformer is a sine wave and its amplitude depends on the country where we live (110/220 VAC or other).

2.2.2 TRANSFORMER:

Transformers are devices that change (transform) the voltage of power supplied to meet the individuals needs of power consumers. It uses the principle of electromagnetic induction to change the voltage (alternating difference) from one value to another whether smaller or greater. A transformer is made of a soft iron coil with two other coils wound around it, but not connected with one another. The iron coils can either be arranged on top of another or be wound on separate limbs of the iron core.

The coil to which the alternating voltage is supplied is known as primary winding or primary coil while. The alternating current in the primary winding produces a changing magnetic field around it whenever an alternating potential is supplied. An alternating current is in turn produced by the changing field in the secondary coil and the amount of current produced depends on the number of windings in the secondary coil.

Step-Down Transformer:

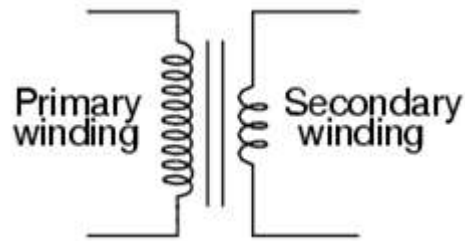

2.2.3 RECTIFIER

A rectifier is an electrical device composed of one or more diodes that converts alternating current (AC) to direct current (DC). A diode is like a one-way valve that allows an electrical current to flow in only one direction. This process is called rectification.

(OR)

A rectifier is an electrical device that converts AC to DC. AC regularly reverses direction, while DC flows in one direction only. Rectification produces a type of DC that encompasses active voltages and currents, which are then adjusted into a type of constant voltage DC, although this varies depending on the current's end use. The current is allowed to flow uninterrupted in one direction, and no current is allowed to flow in the opposite direction. Almost all rectifiers contain more than one diode in particular arrangements. A rectifier also has different waveforms, such as:

Half Wave:-Either the positive or negative wave is passed through and the other wave is blocked. It is not efficient because only half of the input wave form reaches the output. **Full Wave:** Reverses the negative part of the AC wave form and combines it with the positive

Single-Phase AC: Two diodes can form a full-wave rectifier if the transformer is center-tapped. Four diodes arranged in a bridge are needed if there is no center-tap.

Three-Phase AC: Generally uses three pairs of diodes

One of the key problems with rectifiers is that AC power has peaks and lows, which may not produce a constant DC voltage. Usually a smoothing circuit or filter needs to be coupled with the power rectifier to produce a smooth DC current.

2.2.4 FILTER

The filter, formed by one or more capacitors, flattens or smoothers the previous wave eliminating the alternating current(AC) component delivered by the rectifier. These capacitors are charged to the maximum

voltage value that the rectifier can deliver and discharge when the pulsating signal disappears .

2.2.5 VOLTAGEREGULATOR (LM7805)

The voltage regulator receives the signal from the filter and delivers a constant voltage (let's say 12 DC volts) regardless of the variations on the load or the voltage supply. A variable regulated power supply, also called a variable bench power supply, is one where you can continuously adjust the output voltage to your requirements. Varying the output of the power supply is the recommended way to test a project after having double checked parts placement against circuit drawings and the parts placement guide. This type of regulation is ideal for having a simple variable bench power supply. Actually this is quite important because one of the first projects a hobbyist should undertake is the construction of a variable regulated power supply. While a dedicated supply is quite handy e.g. 5V or 12V, it's much handier to have a variable supply on hand, especially for testing. Most digital logic circuits and processors need a 5 volt power supply. To use these parts we need to build a regulated 5 volt source. Usually you start with an unregulated power supply ranging from 9 volts to 24 volts DC (A 12 volt power supply is included with the Beginner Kit and the Microcontroller Beginner Kit.). To make a 5 volt power supply, we use a LM7805 voltage regulator IC (Integrated Circuit). The IC is shown in fig 2.2.3

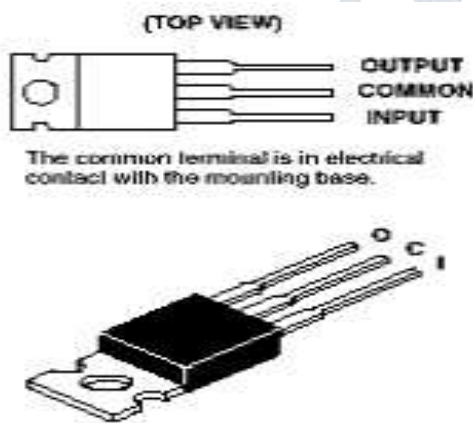

Fig 2.2.3 Voltage Regulator

2.3. RFID SYSTEM:

RFID System can be effectively used for material management and asset tracking. In the few years, Radio Frequency Identification technology has gained a lot of importance and many innovative applications are being developed using this technology. RFID technology is going to revolutionize the business all over the world in coming years.

2.3.1 RFID TRANSMITTER AND RECEIVER

The RF module, as the name suggests, operates at Radio Frequency. The corresponding frequency range varies between 30 kHz & 300 GHz. In this RF system, the digital data is represented as variations in the amplitude of carrier wave. This kind of modulation is known as Amplitude Shift Keying (ASK). Transmission through RF is better than IR (infrared) because of many reasons. Firstly, signals through RF can travel through larger distances making it suitable for long range applications. Also, while IR mostly operates in line-of-sight mode, RF signals can travel even when there is an obstruction between transmitter & receiver. Next, RF transmission is more strong and reliable than IR transmission. RF communication uses a specific frequency unlike IR signals which are affected by other IR emitting sources.

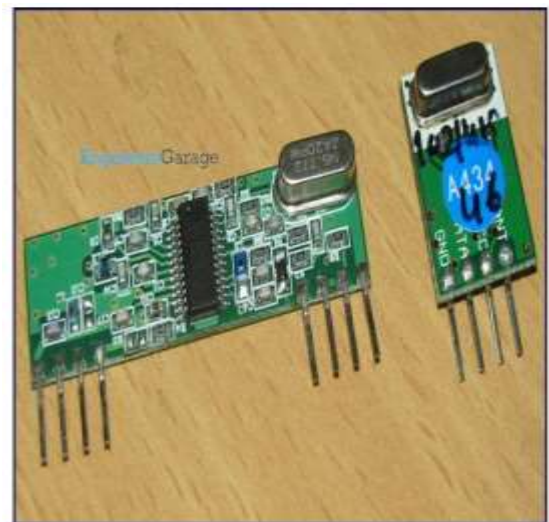

Fig 2.3.1 RF Transmitter and RF Receiver

This **RF module** comprises of an **RF Transmitter** and an **RF Receiver** as shown in fig 2.3.1. The transmitter/receiver (Tx/Rx) pair operates at a frequency of **434 MHz**. An RF transmitter receives serial data and transmits it wirelessly through RF through its antenna connected at pin4 as shown in fig 2.3.2. The transmission occurs at the rate of 1Kbps - 10Kbps. The transmitted data is received by an RF receiver operating at the same frequency as that of the transmitter. The RF module is often used along with a pair of encoder/decoder. The encoder is used for encoding parallel data for transmission feed while reception is decoded by a decoder. [HT12E-HT12D](#), HT640-HT648, etc. are some commonly used encoder/decoder pair ICs.

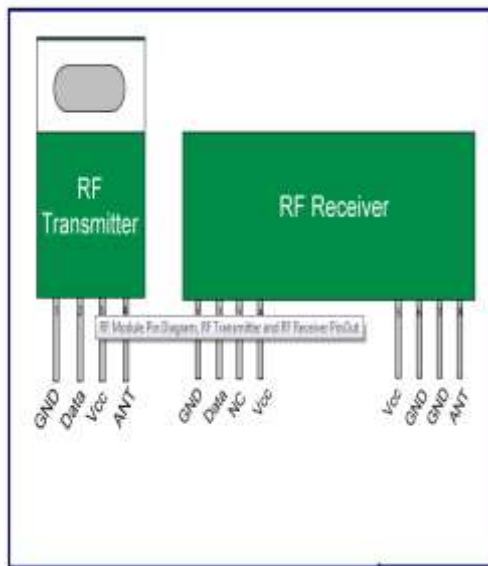

Fig 2.3.2 Pin Diagram of RF Transmitter and Receiver

Pin Description:

RF Transmitter

Pin No	Function	Name
1	Ground (0V)	Ground
2	Serial data input pin	Data
3	Supply voltage: 5V	Vcc
4	Antenna output pin	ANT

RF Receiver

Pin No	Function	Name
1	Ground (0V)	Ground
2	Serial data output pin	Data
3	Linear output pin, not connected	NC
4	Supply voltage: 5V	Vcc
5	Supply voltage: 5V	Vcc
6	Ground (0V)	Ground
7	Ground (0V)	Ground
8	Antenna input pin	ANT

2.3.2 RF TAGS

RFID tag is a compact “system on chip” with a micro-controller, memory, modern circuitry and radio module along with an antenna. Data can be written into the memory of the tag from the RFID reader. The communication between the reader and the tag is through radio frequencies and hence there is no need for a physical contact between the tag and the reader. As a result, all the drawbacks listed for bar code system do not exist for RFID systems. The RFID reader reads the data from the RFID tag and, is so capable of writing data onto the tag. When the tag is in the radio vicinity of the

reader, the reader reads the data from the tag and then the data can be transferred through RS232 or USB interface to a PC. The PC can be connected to a backbone network. It is the backbone network that gives the power to the RFID system. The data on the tag can be made accessible anywhere in the world leading to gobble supply chain management system.

RFID tagging is an ID system that uses small [radio frequency identification](#) devices for identification and tracking purposes. An RFID tagging system includes the tag itself, a read/write device, and a host system application for data collection, processing, and transmission. An RFID tag (sometimes called an RFID [transponder](#)) consists of a [chip](#), some memory and an [antenna](#). RFID tags that contain their own power source are known as *active* tags. Those without a power source are known as *passive* tags. A passive tag is briefly activated by the radio frequency (RF) scan of the reader. The electrical current is small -- generally just enough for transmission of an ID number. Active tags have more memory and can be read at greater ranges.

Increasingly, RFID tagging is used in [supply chain management](#) as an alternative to [bar code](#) technology. Although more expensive to use than the bar code stickers, RFID tags don't get dirty or fall off or require an unobstructed line-of-sight between the tag and the reader. There are almost endless possible uses for RFID tagging. Injectable ID chips have been used to track wildlife and livestock for over a decade. An injectable RFID tag called the [VeriChip](#) can be used to help medical personnel identify a patient who is unable to speak and even provide access to the person's medical records. RFID tagging is somewhat controversial because the tags could theoretically be cloned or used for illicit tracking.

2.3.3 RFID READER

A RFID reader is a device used to gather information from an RFID tag, which is used to track individual objects. Radio waves are used to transfer data from the tag to a reader. RFID is a technology similar in theory to bar codes. However, the RFID tag does not have to be scanned

directly, nor does it require line-of-sight to a reader. The RFID tag it must be within the range of an RFID reader, which ranges from 3 to 300 feet, in order to be read. RFID technology allows several items to be quickly scanned and enables fast identification of a particular product, even when it is surrounded by **identify every item. RFID technology may be used in a variety of applications** including: pass ports, smart cards, air plane luggage, monitoring heart patients, home appliances several other items. RFID tags have not

replaced bar codes because of their cost and the need to individually

RFID technology uses digital data in an RFID tag, made up of circuits containing a tiny antenna for transferring information to an RFID transceiver. The majority of RFID tags contain at least an integrated circuit for modulating and demodulating radio frequency and an antenna for transmitting and receiving signals. Frequency ranges vary from low frequencies of 125 to 134 kHz and 140 to 148.5 kHz, and high frequencies of 850 to 950 MHz and 2.4 to 2.5 GHz. Wavelengths in the 2.4 GHz range are limited because they can be absorbed by water.

2.3.3.APPLICATIONS::

Each and every product/ item can be attached with an RFID tag. And, when the tag comes in the vicinity of the reader, the contents of the tag can be read by him then processed/ sent over a network. The power of the RFID Technology comes integrating this information with the corporate network or even the global internet. Some important applications are

Asset Tracking: Every valuable asset can be tracked using RFID. Computers, Instruments, Machinery, etc., in an organization can be attached with tags to make asset verification easier. When assets are moved from one place to another, their moment can be tracked easily. RFID tags are used for tracking of animals also.

Inventory Management: Manufacturing organizations can use RFID Technology for efficient Inventory management. Automobile Industry uses this technology in the production facilities. Each Manufactured part of the car is attached with a tag, the tag stores the details of the part.

Transport Management: Transport organizations have been the greatest beneficiaries of RFID Technology. In public transport systems, a lot of money is spent on ticketing. Ticketing can be automated completely using RFID system. Each bus can have an RFID reader and the public can given debit cards. The pair will be automatically deducted from the card at the time of entry in to 3the bus, the reader will write in to the tag the point of entry and when the user alights from the bus, the pair will be calculated and deducted from the card.

Sensor Networks: The RFID tags can be Integrated with sensors such as Temperature sensors, Pressure sensors etc., so that the sensors information can be transferred to the reader and from the reader to another controlling device.

2.4 IR SENSOR

IR Sensors work by using a specific light sensor to detect a select light wavelength in the Infra-Red (IR) spectrum. By using an LED which produces light at the same wavelength as what the sensor is looking for, you

can look at the intensity of the received light. When an object is close to the sensor, the light from the LED bounces off the object and into the light sensor as shown in fig 2.4.1. This results in a large jump in the intensity, which we already know can be detected using a threshold.

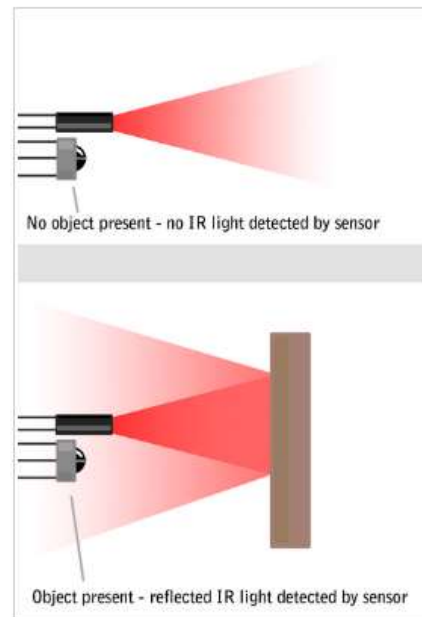

Fig 2.4.1a Depiction of the Operation of the IR Sensor

2.4.1 Detecting Brightness:

Since the sensor works by looking for reflected light, it is possible to have a sensor that can return the value of the reflected light. This type of sensor can then be used to measure how "bright" the object is as shown in fig 2.5.2. This is useful for tasks like line tracking.

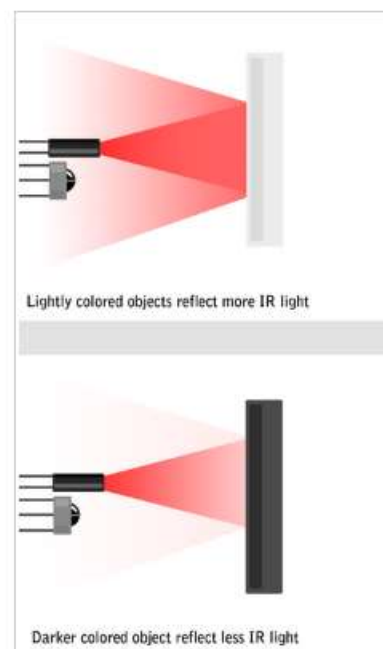

Fig 2.4.1b Depiction of the Operation of the IR Sensor to Measure Brightness

2.4.2 FEATURES:

- Very low supply current
- Photo detector and preamplifier in one package
- Internal filter for PCM frequency
- Supply voltage: 2.5 V to 5.5 V
- Improved immunity against ambient light
- Insensitive to supply voltage ripple and noise
- Material categorization:

Uno means one in Italian and is named to mark the upcoming release of Arduino 1.0. The Uno and version 1.0 will be the reference versions of Arduino, moving forward. The Uno is the latest in a series of USB Arduino boards.



Fig 2.5.1 General Diagram of Arduino

Infrared radiation is the portion of electromagnetic spectrum having wavelengths longer than visible light wavelengths, but smaller than microwaves,

2.5 ARDUINO UNO R3 (Micro controller)

The Arduino Uno is a microcontroller board based on the ATmega328. It has 14 digital input/output pins (of which 6 can be used as PWM outputs), 6 analog inputs, a 16 MHz ceramic resonator, a USB connection, a power jack, an ICSP header, and a reset button. It contains everything needed to support the microcontroller; simply connect it to a computer with a USB cable or power it with a AC-to-DC adapter or battery to get started. The Uno differs from all preceding boards in that it does not use the FTDI USB-to-serial driver chip. Instead, it features the Atmega16U2 (Atmega8U2 up to version R2) programmed as a USB-to-serial converter. The Uno board has a resistor pulling the 8U2 HWB line to ground, making it easier to put into DFU mode. The board has the following new features:

- 1.0 pinout are to added SDA and SCL pins that are near to the AREF pin and two other new pins placed near to the RESET pin, the IOREF that allow the shields to adapt to the voltage provided from the board. In future, shields will be compatible with both the board that uses the AVR, which operates with 5V and with the Arduino Due that operates with 3.3V. The second one is a not connected pin, that is reserved for future purposes.
- Stronger RESET circuit.
- Atmega 16U2 replace the 8U2, as shown in fig 2.5.2.

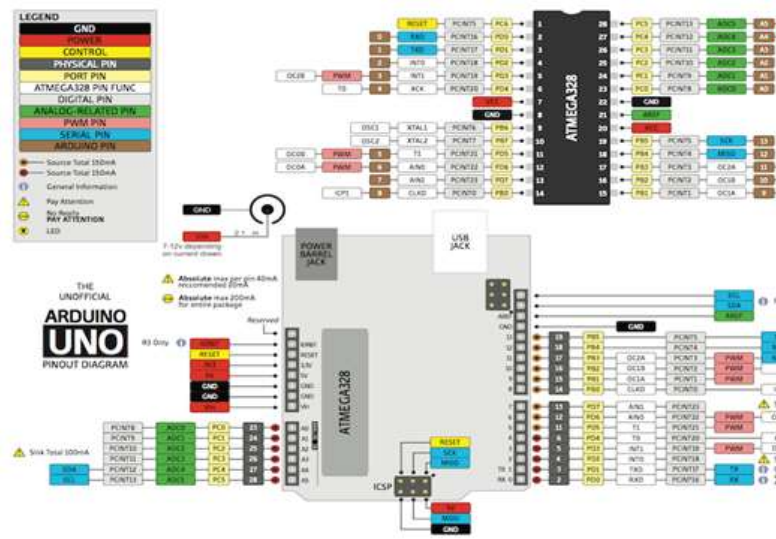

Fig 2.5.2 Pin Diagram of Arduino

2.5.1 Description:

Microcontroller	ATmega328
Operating Voltage	5V
Input Voltage(recom)	7-12V
Input Voltage (limits)	6-20V
Digital I/O Pins	14 (of which 6 provide PWM output)
Analog Input Pins	6
DC Current per I/O Pin	40 mA

DC Current for 3.3V Pin	50 mA
Flash Memory	32 KB (ATmega328) of which 0.5 KB used by bootloader
SRAM	2 KB (ATmega328)
EEPROM	1 KB (ATmega328)
Clock Speed	16 MHz
Length	68.6 mm
Width	53.4 mm
Weight	25 g

2.6 L293D MOTOR DRIVER

We discuss about L293D motor driver working for motors. The L293 and L293D are quadruple high-current half-H drivers. Here we learn about hybrid bridges (H-BRIDGE). The hi-bridges which are mainly used in change of polarities. There are two polarities in every motor. In L293D two h-bridges are present. Four transistors are present in each h-bridge. If we give logic bits 1, 0 then current flow is Vcc to motor positive after that motor positive to negative and then flows to ground. Then motor rotates in one direction. We change the logic bits as 0, 1 then current flow is Vcc to motor negative after that motor negative to positive and then flows to ground. Then motor rotate in opposite direction. If we give logic bits 1, 1 then Vcc and ground are short. So motor does not rotate. If we give logic bits 0, 0 then motor does not start. Because two pins are given to zero.

The L293 is designed to provide bidirectional drive currents of up to 1 A at voltages from 4.5 V to 36 V. The L293D is designed to provide bidirectional drive currents of up to 600-mA at voltages from 4.5 V to 36 V. Both devices are designed to drive inductive loads such as relays, solenoids, dc and bipolar stepping motors, as well as other high-current/high-voltage loads in positive-supply applications. All inputs are TTL compatible. Each output is a complete totem-

pole drive circuit, with a Darlington transistor sink and a pseudo-Darlington source. Drivers are enabled in pairs, with drivers 1 and 2 enabled by 1,2EN and drivers 3 and 4 enabled by 3,4EN. When an enable input is high, the associated drivers are enabled and their outputs are active and in phase with their inputs. When the enable input is low, those drivers are disabled and their outputs are off and in the high-impedance state. With the proper data inputs, each pair of drivers forms a full-H (or bridge) reversible drive suitable for solenoid or motor applications. On the L293, external high-speed output clamp diodes should be used for inductive transient suppression. A VCC1 terminal, separate from VCC2, is provided for the logic inputs to minimize

device power dissipation. The L293 and L293D is characterized for operation from 0°C to 70°C. The pin diagram is shown in fig 2.6

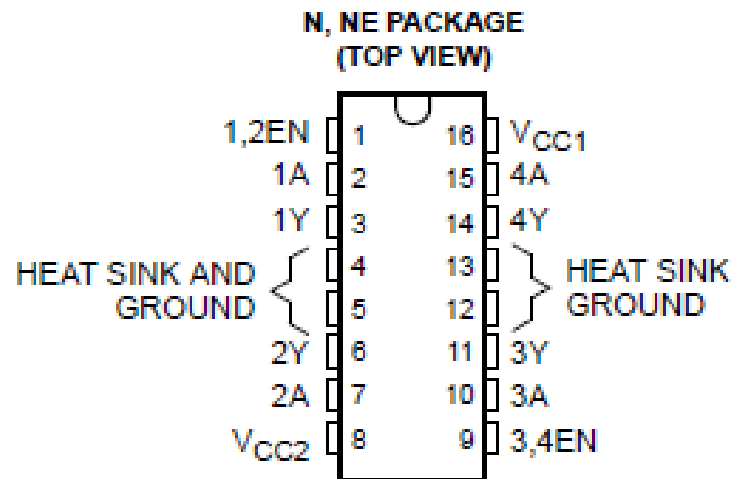

Fig 2.6 Pin Diagram of Motor Driver

2.7 PUSH BUTTONS

A push-button shown in fig 2.7 is a simple switch mechanism for controlling some aspect of a machine or a process. Buttons are typically made out of hard material, usually plastic or metal. The surface is usually flat or shaped to accommodate the human finger or hand, so as to be easily depressed or pushed. Buttons are most often biased switches, though even many un-biased buttons (due to their physical nature) require a spring to return to their un-

pushed state. Different people use different terms for the "pushing" of the button, such as press, depress, mash, hit, and punch.



Fig 2.7 General Diagram of Push Button

2.7.1 USES:

- The "push-button" has been utilized in calculators, push-button telephones, kitchen appliances, and various other mechanical and electronic devices, home and commercial.
- In industrial and commercial applications, push buttons can be connected together by a mechanical linkage so that the act of pushing one button causes the other button to be released. In this way, a stop button can "force" a start button to be released. This method of linkage is used in simple manual operations in which the machine or process have no electrical circuits for control.
- Pushbuttons are often color-coded to associate them with their function so that the operator will not push the wrong button in error. Commonly used colours are red for stopping the machine or process and green for starting the machine or process.
- Red pushbuttons can also have large heads (called mushroom heads) for easy operation and to facilitate the stopping of a machine. These pushbuttons are called emergency-

-stop buttons and are mandated by the electrical code in many jurisdictions for increased safety. This large mushroom shape can also be found in buttons for use with operators who need to wear gloves for their work and could not actuate a regular flush-mounted push button. As an aid for operators and users in industrial or commercial applications, a pilot light is commonly added to draw the attention of the user and to provide feedback if the button is pushed. Typically this light is included into the centre of the pushbutton and a lens replaces the pushbutton hard centre disk. The source of the energy to illuminate the light is not directly tied to the contacts on the back of the pushbutton but to the action the pushbutton controls. In this way a start button when pushed will cause the process or machine operation to be started and a secondary contact designed into the operation or process will close to turn on the pilot light and signify the action of pushing the button caused the resultant process or action to start.

2.8 DC MOTOR INTERFACING

In this project the d.c motor interfacing consists of two motors .One motor is used to open & close the car door and the other is used to move the car forward. This uses L293D IC interfacing.

2.8.1 PUSH-PULL FOUR CHANNEL DRIVER (load driver)

Description

Output current is 1A or 600mA per channel respectively. Each channel is controlled by a TTL-compatible logic input and each pair of drivers (a The L293 and L293D are quad push-pull drivers capable of delivering full bridge) is equipped with an inhibit input which turns off all four transistors. A separate supply input is provided for the logic so that it may be run off a lower voltage to reduce dissipation. Additionally the L293D includes the output clamping diodes

Within the IC for complete interfacing inductive loads. Both devices are available in 16-pin Batwing DIP packages. They are also available in Power SOIC and Hermetic DIL packages.The general block diagram of load drive is shown in

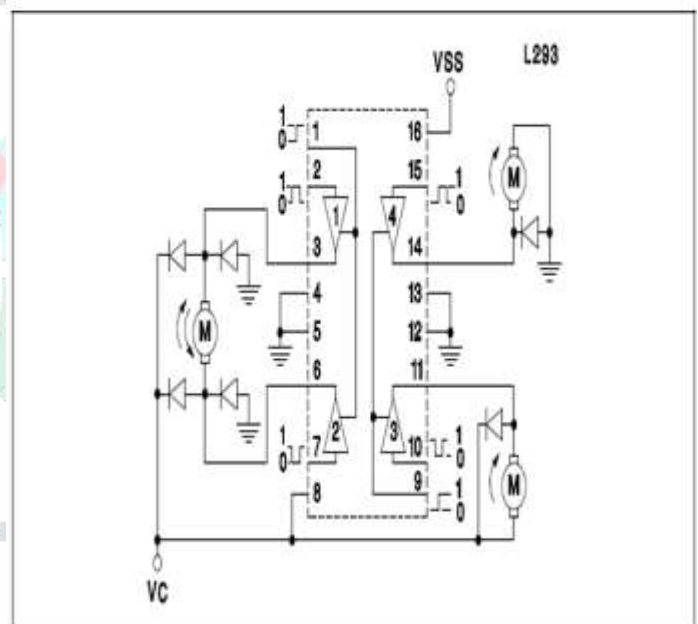

Figure 2.8.1: block diagram of load driver L293D

2.8.2 FEATURES:

- Output Current 1A Per Channel (600mA for L293D)
- Peak Output Current 2A Per Channel (1.2A for L293D)
- Inhibit Facility
- High Noise Immunity
- Separate Logic Supply
- Over-Temperature Protection

2.9 RFID TECHNOLOGY

Radio-frequency identification (RFID) uses electromagnetic fields to automatically identify and track tags attached to objects. The tags contain electronically stored information. Passive tags collect energy from a nearby RFID reader's interrogating radio waves. Active tags have a local power source such as a battery and may operate at hundreds of meters from the RFID reader. Unlike a barcode, the tag need not be within the line of sight of the reader, so it may be embedded in the tracked object. RFID is one method for Automatic Identification and Data Capture (AIDC).

RFID tags are used in many industries, for example, an RFID tag attached to an automobile during production can be used to track its progress through the assembly line; RFID-tagged pharmaceuticals can be tracked through warehouses; and implanting RFID microchip in livestock and pets allows positive identification of animals. Since RFID tags can be attached to cash, clothing, and possessions, or implanted in animals and people, the possibility of reading personally-linked information without consent has raised serious privacy concerns.^[21] These concerns resulted in standard specifications development addressing privacy and security issues. ISO/IEC 18000 and ISO/IEC 29167 use on-chip cryptography methods for untraceability, tag and reader authentication, and over-the-air privacy. ISO/IEC 20248 specifies a digital signature data structure for RFID and barcodes providing data, source and read method authenticity. This work is done within ISO/IEC JTC 1/SC 31 Automatic identification and data capture techniques (AIDC).

AUTOMATIC IDENTIFICATION AND DATA CAPTURE (AIDC): Automatic identification and data capture (AIDC) refers to the methods of automatically identifying objects, collecting data about them, and entering that data directly into computer systems (i.e. without human involvement). Technologies typically considered as part of AIDC include bar codes, Radio Frequency Identification (RFID), biometrics, magnetic stripes, Optical Character Recognition (OCR), smart cards, and voice recognition. AIDC is also commonly referred to as “Automatic Identification,” “Auto-ID,” and “Automatic Data Capture”

AIDC is the process or means of obtaining external data, particularly through analysis of images, sounds or videos. To capture data, a transducer is employed which converts the actual image or a sound into a digital file. The file is then stored and at a later time it can be analysed by a computer, or compared with other files in a database to verify identity or to provide authorization to enter a secured system.

Capturing of data can be done in various ways; the best method depends on application.

AIDC also refers to the methods of recognizing objects, getting information about them and entering that data or feeding it directly into computer systems without any human involvement. Automatic identification and data capture technologies include barcodes, RFID, bokodes, OCR, magnetic stripes, smartcards and biometrics (like iris and facial recognition system). In biometric security systems, capture is the acquisition of or the process of acquiring and identifying characteristics such as finger image, palm image, facial image, iris print or voice print which involves audio data and the rest all involves video data.

Radio-frequency identification (RFID) is relatively a new AIDC technology which was first developed in 1980s. The technology acts as a base in automated data collection, identification and analysis systems worldwide. RFID has found its importance in a wide range of markets including livestock identification and Automated Vehicle Identification (AVI) systems because of its capability.

2.10 VOICE MODULE

Today's consumers demand the best in audio/voice. They want crystal-clear sound whenever they are in whatever format they want to use. APLUS delivers the technology to enhance a listener's audio/voice experience

The APR33A3[5] is a powerful audio processor along with high performance audio analog to digital converter (ADC) and digital to analog converter (DAC). The APR33 is a fully integrated solution offering high performance and unparalleled integration with analog input, digital processing and analog output functionality. The APR33A incorporates all the functionality required to perform demanding audio/voice applications. High quality audio/voice systems with lower bill of material costs can be implemented with the APR33A3 because of its integrated analog data converters and full suite of quality enhancing features such as sample rate converter

The APR33A series C3.1 is Tape mode manages messages sequentially much like traditional cassette tape recorders. Within tape mode two options exist, auto rewind and non-auto rewind. Auto rewind mode configures the device to automatically rewind to the beginning of the message immediately following recording or playback of the message. In tape mode, using either option, messages must be recorded or played back sequentially, much like a traditional cassette tape

recorder specially designed for simple key trigger, user can record and playback the message. Meanwhile, this mode provides the power-management system. Users can let the chip enter power-down mode when unused. It can effectively reduce electric current consuming to 15uA and increase the using time in any projects powered by batteries.

2.10.1 FEATURES:

- Operating Voltage Range:3V-6.5V
- Single Chip ,high Quality Audio/voice Recording &Play black solution No External ICs Required
- Minimum External Components user Friendly ,Easy to Use Operation
- Programming & Development Systems Not Required
- Non-volatile Flash Memory Technology
- No Battery Backup Required External Reset Pin.
- Low Power Down Current:15micro amp
- Resolution Up to 16 –bits

2.10.2 Pin Configuration of IC

Speakers are the final components of the audio chain—the interface between electrical signals and sound. With few exceptions, a typical speaker enclosure contains several transducers that disperse sound into your living room. The sound seemingly spreads every which way and may bounce off the walls, carpet, or furniture several times and to various degrees before it arrives at your ears. The more I think about this the harder I find it to understand why this does not result in total sonic chaos.

To make it easier to understand, I could ignore the living room for now and look at speakers in an anechoic chamber. But since I don't own a speaker lab, I'd have to drag the speakers out into my back yard, put them on a high pole, and have them speak towards the sky. This has a similar benefit as the anechoic chamber in that hardly any sound bounces off my lawn and none off the sky. If I looked at the speakers from above, with a microphone attached to an even higher pole, this should give me almost anechoic results. Unfortunately, living in the

Pacific Northwests [*sic*], this is not an option either, at least most of the time.

Enter the computer. My speaker design software ([Lspcad](#)) lets me simulate many of these things. Understanding that simulations likely simplify reality, I still find them *very* educational. For instance, to simulate the behaviour of speakers in a room, the software lets me specify width, length, and height of my living room, along with the size of the speakers, the transducer positions on the enclosure, the rates at which my walls, floor, and ceiling absorb or reflect sound, and the position of my ear. Granted, my living room is L-shaped, and I have two ears, but it's a start, and it is way easier to change the speaker position in a dialog box than constantly moving around large pieces of furniture.

I still remember the first time I saw the simulated in-room frequency response curve after entering all the numbers, particularly my haphazard speaker positioning choices. These choices can ruin the best speakers, and my speakers were nowhere nearly the best. I played around with

SOFTWARE REQUIREMENTS

3.1 Introduction:

<http://Arduino.cc/en/Main/Software>

Otherwise, the USB stick in your kit2 has the software under the Software Directory. There are two directories under that. One is “Windows” and the other is “Mac OS X”. If you are installing onto Linux, you will need to follow the directions at ref.[2].

3.1 The Integrated Development Environment (IDE):

You use the Arduino IDE on your computer (picture following) to create, open, and change sketches (Arduino calls There are step-by-step directions and the software available at:programs “sketches”. We will use the two words interchangeably in this book.). Sketches define what the board will do. You can either use the buttons along the top of the IDE or the menu items.

Fig: 3.1 Environment of IDE.

3.1.1 Parts of the IDE: (from left to right, top to bottom)

1. **Compile-** Before your program “code” can be sent to the board, it needs to be converted into instructions that the board understands. This process is called compiling.
2. **Stop-** This stops the compilation process.(I have never used this button and you probably won't have a need to either).
3. **Create new Sketch-** This opens a new window to create a new sketch.
4. **Open Existing Sketch-** This loads a sketch from a file on your computer.

5. **Save Sketch-** This saves the changes to the sketch you are working on.
 6. **Upload to Board-** This compiles and then transmits over the USB cable to your board.
 7. **Tab Button-** This lets you create multiple files in your sketch. This is for more advanced programming.
 8. **Sketch Editor-** This is where you write or edit sketches.
-
9. **Text Console-** This shows you what the IDE is currently doing and is also where error messages display if you make a mistake in typing your program (often called a syntax error).
 10. **Line Number-** This shows you what line number your cursor is on. It is useful since the compiler gives error messages with a line number.

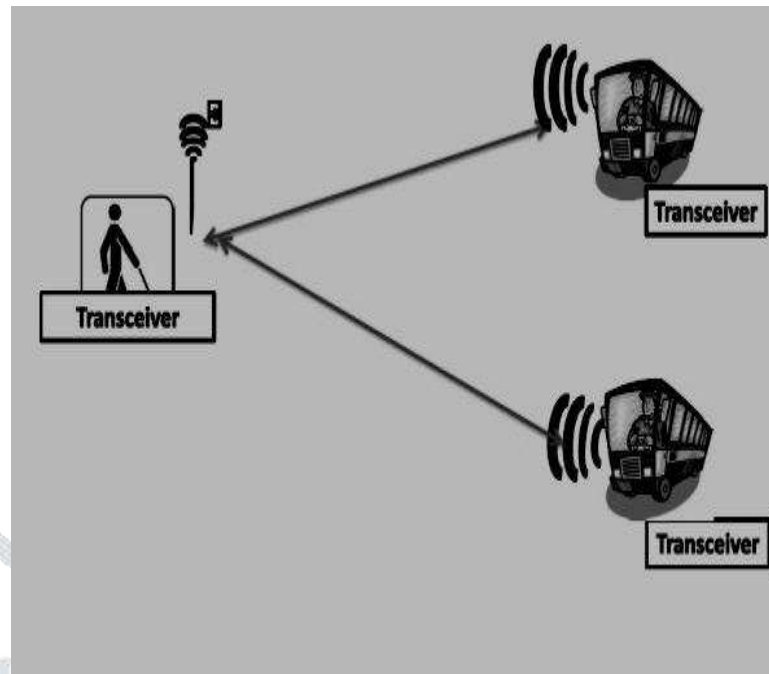

3.2 Features of Arduino Programming:

- Easy-to-use.
- Full Arduino™ compatible
- Supported file formats and programming languages: Arduino, C, C++, Header, HTML, HTML5, JavaScript, CSS, Text
- IDE languages (English, German)
- Supports all Arduino libraries.
- Object & Function Explorer.
- Code Autocompletion.
- Code Folding.
- Bookmarks.
- Hints & Information about the Arduino commands.
- Advanced Reference Search Function (File Cross-Search)
- Website editor for IoT applications with Arduino.
- Comfortable and powerful code editor.
- Export function to Arduino IDE (good way for older Arduino versions less 1.6.x)
- Manage full project without project files in one editor
- Value Converter (DEC, HEX, BIN, ASCII)

WORKING OF THE MODEL

4.1 VIP MODULE:

The blind people section consists of RFID reader, AT89C51 microcontroller, power supply, voice synthesizer, headset, RF transmitter as shown in fig. The 5V dc is given to operate the microcontroller. When the tag is interpreted or decoded, the sequence is displayed as numbers unique to the tag. Since it makes use of the Radio frequency interference technique, Radio frequency helps in decoding the information. The radio frequency used to decode the data in the RFID tag is produced by the RFID reader. The RFID reader obtains the address of the desired RFID tag (the address differs from each tag) the identified tag when attached to the bus will be the reference to that bus and is indirectly detected. Then the RS 232 is used to transmit the serial information to the microcontroller and it is designed to provide a voice based announcement for the user. So that the user gets the voice which pronounces the destination location. APR9600 device offers true single chip voice recording, non-volatile

storage and play back capability for 40-60 seconds. Then the information in the voice IC is heard in the speaker.

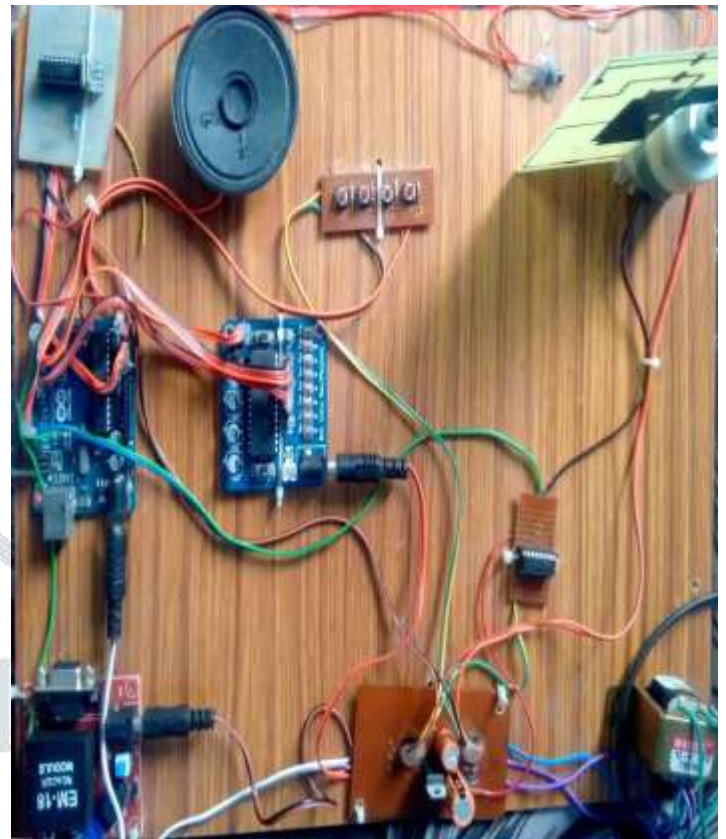

4.2 BUS MODULE:

The bus section consist of RFID tag,RF receiver, buzzer and battery as shown in fig. The first step of application is to intimate the bus driver about the bus stop, so that the driver can provide the special attention at VIP Person is boarding bus.By using wireless communication of transmitters and receivers nature of RF protocols using TWS 434 and RWS 434. The TWS-434 transmitter accepts both linear and digital inputs can operate from 1.5 to 12 Volts-DC. The P2_0, P2_1, P2_2and P2_3 pin of controller is assumed as data transmit pins. The DATA_OUT pin of encoder is connected to the DATA_IN pinof RF Transmitter and then the RF Transmitter transmits the data to the receiver. The RWS 434receiver operates from 4.5 to 5.5 volts-DC and has both linear and digital out puts. The P2_0, P2_1, P2_2 and P2_3 pin of controller is assumed as data transmit pins. The DATA_OUT pin of RF Transmitter is connected to the DATA_IN pin of DECODER and then the data is processed by the decoder.The receiver which has the 12Vbattery receives the radio wave from the transmitter which activates the buzzer. The buzzer issued to indicate the presence of VIP person to the driver

CONCLUSION:

Since the estimated number of blind people over the world is between 40 to 45 million, special services should be provided to them in order to give them the right to live as others do. In this paper, we presented a bus detection system for blind people using RFID. The proposed system is easy and provides a convenient service for all the passengers; not only the blind ones. The system has two subsystems which are: the bus subsystem and the station subsystem. Bus subsystem announces the coming stations in the bus route for all passengers. 50 Moreover, the bus driver will be provided with the number of blind people who required the bus and their destinations. The station sub-system will give announcement of the approaching buses. A prototype of the proposed system was successfully built and tested. Our design is promising in terms of its performance and functionality.

FUTURE SCOPE:

This prototype to assist the Visionless people while boarding the bus has wide applications other than just helping the blind people inform their presence to the bus driver. In further stages of development this project can be used to enhance the safety and comfort of a

larger section of society. Following are some of the anticipated future scopes: 1. This system can be installed over the taxis and not just public buses, all over the city so that people can very easily communicate with them. 2. This system, if manufactured commercially, is very economic and thus can be made available at the stores so that women, children, senior citizens or any section of society can use it. 3. With few changes in the hardware and programming, this prototype can be turned into a security device. Women may have this all the time with them while they are out of their homes. Each policeman will also be handed over one device. So whenever any woman feels any kind of danger,

REFERENCE

- 1 New York Transportation Statistics. Available from: <http://transportation-modescity.findthedata.org/q/1447/1033/Howmany-people-use-public-transportation-to-commute-in-New-YorkNew-York>. Accessed 25 November 2015.
- 2 Hersh, M.A., Johnson, M.A. Assistive Technology for Visually Impaired and Blind People, Springer, 2008. 51
- 3 Miesenberger, K. [et al.] [eds.] Computers Helping People with Special Needs, LNCS, vol. 4061 Springer Berlin / Heidelberg, 10th International Conference, ICCHP 2006, Linz, Austria, July 11-13, 2006.
- 4 Implementation of RFID for blind bus boarding system B.N Kiran, Smitha B.C, Sushma K.N, Varsha R.Gowda,"International Journal of Science Engineering and Applied Science(IJSEAS)-Volume 1.
- 5 Myat K Khine, Thiri Thandar Aung,"RFID- based Audio Guidance Cane For Blind and Visually Impaired Person, International Journal of Engineering Research & Technology(IJERT), Vol. 3 Issue 8, August -2014.
- 6 Quoc T., Kim M., Lee H. and Eom k., "Wireless Sensor Network apply for the Blind U-bus System," International Journal of u- and eService, Science and Technology Vol. 3, No. 3, September, 2010.
- 7 On The Bus Public Transport. Available at: <http://www.onthebusproject.com>, Accessed 25 November 2015.