

MODELLING AND OPTIMAL CONTROL OF TWO LINK PLANAR ARM

¹Mohan Bukya, ²K.Naresh

¹Assistant Professor, ² Assistant Professor

¹Department of EEE, ²Department of EEE

¹Vardhaman College of Engineering, Hyderabad, Telangana, India.

¹Usha Rama College of Engineering and Technology, Vijayawada, Andhra Pradesh, India.

Abstract- This paper focuses on the modelling and control of a two-link planar arm that emulates a human arm. The system model derived both in the 2nd-order differential equation formulation and state-variable formulation, the system is linearized around equilibrium point for analysis. The arm is subjected to a disturbance at a specific location on the arm while performing trajectory tracking tasks in two-dimensional space. A closed-loop control system is applied using LQR control to observe the system responses like state tracking, position and velocity control. These results of the study show the effectiveness of the proposed method in eliminating the unwanted disturbance effect to produce robust position, velocity and accurate tracking performance of the system.

Index Terms - Lagrange's equation, Modelling, Linearization, Linear Quadratic Regulator, State tracking.

1. Introduction

The dynamics of planar manipulator is highly nonlinear which makes difficult their efficient control, there are many conventional control methods are available however they are inefficient for powerful nonlinearities in the model. On the other hand nonlinear controllers give rise to better performance but the nonlinear design and analysis is not easy as much linear case[1]. Optimal control theory plays a key role in the study of biological movement[2]. The dynamics of robot could change significantly by an operation such as picking of a payload or changing relative orientation of linkages[3]. LQR is an optimal multivariable feedback control approach that minimizes the deviation in state trajectories of a system while requiring minimal control effort. The behaviour of a LQR controller is determined by two parameters: state and control weighted matrices[4]. This paper was organized in following manner, section 2. Derivation of dynamics of two link arm, 2.2. Linearization of two link arm, 2.3. Linear Quadratic Regulator problem formulation, 2.4. Position control, 2.5. Simulation and 3. Conclusion.

2. The dynamics of two link arm

The arm dynamical equations are derived both in the 2nd-order differential equation formulation and state-variable formulations. In this paper, we first formulate the kinematics and dynamics of a 2-link arm and then add realistic muscle actuators to it.

2.1. Lagrange's Equations of Motion: Lagrange's equation of motion for a conservative system are given by [Marion 1965]

$$T = \frac{d}{dt} \left(\frac{\partial L}{\partial \dot{q}} \right) - \left(\frac{\partial L}{\partial q} \right) \quad (1)$$

Where q is an n -vector of generalized coordinates q_i , is an n -vector of generalized forces T_i , and the Lagrangian, L is the difference between the kinetic(K) and potential(P)energies,

$$L = K - P \quad (2)$$

In our usage, q will be the joint-variable vector, consisting of joint angles θ_i (in degrees or radians). Then T is a vector that has components n_i of torque (Newton-meters) corresponding to the joint angles.

To determine its dynamics, we have assumed that the link masses are concentrated at the ends of the links Fig. 1.

The joint variable is $q = [\theta_1 \quad \theta_2]^T$ and the generalized torque vector is $T = [T_1 \quad T_2]^T$, where T_1, T_2 torques supplied by the actuators.

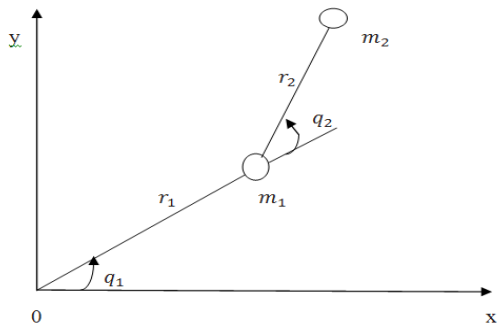

Fig. 1. Two Link Planar Arm

According to Lagrange's equation, the arm dynamics are given by the two coupled nonlinear differential equations[3].

$$T_1 = [(m_1 + m_2)r_1^2 + m_2r_2^2 + 2m_2r_1r_2 \cos \theta_2 + J_1 + J_2] \ddot{\theta}_1 + [m_2r_2^2 + m_2r_1r_2 \cos \theta_2 + J_2] \ddot{\theta}_2 - m_2r_1r_2(2\dot{\theta}_1\dot{\theta}_2 + \dot{\theta}_2^2) \sin \theta_2 + (m_1 + m_2)gr_1 \cos \theta_1 + m_2gr_2 \cos(\theta_1 + \theta_2) \quad (3)$$

$$T_2 = [m_2r_2^2 + m_2r_1r_2 \cos \theta_2 + J_2] \ddot{\theta}_1 + (m_2r_2^2 + J_2) \ddot{\theta}_2 + m_2r_1r_2\dot{\theta}_1^2 \sin \theta_2 + m_2gr_2 \cos(\theta_1 + \theta_2) \quad (4)$$

Based on the equation (3) and (4) we can compute the forward dynamic

$$\ddot{q} = M(q)^{-1}(T - C(q, \dot{q}) - G(q)) \quad (5)$$

and write the 2-link human arm system into a state space form with the state variable $x \in R^4$, Control input $u \in R^2$ as

$$\dot{x} = Ax + bu \quad (6)$$

Where $x = (\theta_1, \theta_2, \dot{\theta}_1, \dot{\theta}_2)^T$, $u = T = (T_1, T_2)^T$

From equations (3) and (4)

$$T_1 = d_{11}\ddot{\theta}_1 + d_{12}\ddot{\theta}_2 + C_1\dot{\theta}_1\dot{\theta}_2 + C_2\dot{\theta}_1^2 + C_3 \quad (7) \quad T_1 = d_{21}\ddot{\theta}_1 + d_{22}\ddot{\theta}_2 + C_4\dot{\theta}_1^2 + C_5 \quad (8) \quad \text{Where}$$

$$d_{11} = (m_1 + m_2)r_1^2 + m_2r_2^2 + 2m_2r_1r_2 \cos \theta_2 + J_1 + J_2 \quad d_{12} = d_{21} = m_2r_2^2 + m_2r_1r_2 \cos \theta_2 + J_2$$

$$C_1 = -2m_1r_1r_2 \sin \theta_2$$

$$C_2 = -m_2r_1r_2 \sin \theta_2$$

$$C_3 = (m_1 + m_2)gr_1 \cos \theta_1 + m_2gr_2 \cos(\theta_1 + \theta_2)$$

$$d_{22} = m_2r_2^2 + J_2$$

$$C_4 = m_2r_1r_2 \sin \theta_2$$

$$C_5 = m_2gr_2 \cos(\theta_1 + \theta_2)$$

Let us consider the state variable as

$$x_1 = \theta_1; \quad x_2 = \dot{\theta}_1; \quad x_3 = \theta_2; \quad x_4 = \dot{\theta}_2$$

by solving the equations (10) and (11) we get the expressions for $\ddot{\theta}_1$ and $\ddot{\theta}_2$ as from equation (11).

$$\ddot{\theta}_1 = \frac{1}{d_{21}} (T_2 - d_{22}\ddot{\theta}_2 - C_4\dot{\theta}_1^2 - C_5) \quad (9)$$

Substitute equation (6) into (5), then we get

$$\ddot{\theta}_2 = \frac{1}{(d_{12}d_{21} - d_{11}d_{22})} (d_{11}C_4\dot{\theta}_1^2 - d_{21}C_2\dot{\theta}_2^2 - d_{21}C_1\dot{\theta}_1\dot{\theta}_2 + d_{11}C_5 - d_{21}C_3 + d_{21}T_1 - d_{11}T_2) \quad (10)$$

Substitute (13) into (12) we get

$$\ddot{\theta}_1 = \frac{1}{(d_{11}d_{22} - d_{12}d_{21})} (d_{12}C_4\dot{\theta}_1^2 - d_{22}C_2\dot{\theta}_2^2 - d_{22}C_1\dot{\theta}_1\dot{\theta}_2 + d_{12}C_5 - d_{22}C_3 + d_{22}T_1 - d_{12}T_2) \quad (11)$$

Thus, the state space model for the two link planar arm can be formed as $\dot{x}_1 = \dot{\theta}_1 = x_2$ (12)

$$\dot{x}_2 = \ddot{\theta}_1 = \frac{1}{(d_{11}d_{22} - d_{12}d_{21})} (d_{12}C_4x_2^2 - d_{22}C_2x_4^2 - d_{22}C_1x_2x_4 + d_{12}C_5 - d_{22}C_3 + d_{22}T_1 - d_{12}T_2) \quad (13)$$

$$\dot{x}_3 = \dot{\theta}_2 = x_4 \quad (14)$$

$$\dot{x}_4 = \ddot{\theta}_2 = \frac{1}{(d_{12}d_{21} - d_{11}d_{22})} (d_{11}C_1x_2^2 - d_{21}C_2x_4^2 - d_{21}C_1x_2x_4 + d_{11}C_5 - d_{21}C_3 + d_{21}T_1 - d_{11}T_2) \quad (15)$$

Where

$$d_{11} = (m_1 + m_2)r_1^2 + m_2r_2^2 + 2m_2r_1r_2 \cos x_3 + J_1 + J_2$$

$$d_{12} = d_{21} = m_2r_2^2 + m_2r_1r_2 \cos x_3 + J_2$$

$$C_1 = -2m_1r_1r_2 \sin x_3$$

$$C_2 = -m_2r_1r_2 \sin x_3$$

$$C_3 = (m_1 + m_2)gr_1 \cos x_1 + m_2gr_2 \cos(x_1 + x_3)$$

$$d_{22} = m_2r_2^2 + J_2$$

$$C_4 = m_2r_1r_2 \sin x_3$$

$$C_5 = m_2gr_2 \cos(x_1 + x_3)$$

2.2. Linearization of two link arm

The non-linear dynamics of the two link will be linearized around the equilibrium point

$$x = [x_1 \ x_2 \ x_3 \ x_4]^T = \left[\frac{\pi}{2} \ 0 \ 0 \ 0\right]^T \text{ using the Taylor series expansion.}$$

Expanding the system dynamics (12) (13) (14) (15) around the equilibrium point, we can write the approximated linear model of the system as

$$\begin{bmatrix} \dot{x}_1 \\ \dot{x}_2 \\ \dot{x}_3 \\ \dot{x}_4 \end{bmatrix} = \begin{bmatrix} 0 & 1 & 0 & 0 \\ \frac{\partial \dot{x}_2}{\partial x_1} & \frac{\partial \dot{x}_2}{\partial x_2} & \frac{\partial \dot{x}_2}{\partial x_3} & \frac{\partial \dot{x}_2}{\partial x_4} \\ 0 & 0 & 0 & 1 \\ \frac{\partial \dot{x}_4}{\partial x_1} & \frac{\partial \dot{x}_4}{\partial x_2} & \frac{\partial \dot{x}_4}{\partial x_3} & \frac{\partial \dot{x}_4}{\partial x_4} \end{bmatrix} \begin{bmatrix} x_1 \\ x_2 \\ x_3 \\ x_4 \end{bmatrix} + \begin{bmatrix} 0 & 0 \\ \frac{\partial \dot{x}_2}{\partial T_1} & \frac{\partial \dot{x}_2}{\partial T_2} \\ 0 & 0 \\ \frac{\partial \dot{x}_4}{\partial T_1} & \frac{\partial \dot{x}_4}{\partial T_2} \end{bmatrix} \begin{bmatrix} T_1 \\ T_2 \end{bmatrix} \quad (16)$$

From equation (12) (13) (14) (15) and (16) the linearized model can be

written as

$$\begin{bmatrix} \dot{x}_1 \\ \dot{x}_2 \\ \dot{x}_3 \\ \dot{x}_4 \end{bmatrix} = \begin{bmatrix} 0 & 1 & 0 & 0 \\ \frac{d_{22}g_1(m_1+m_2)-d_{12}m_2r_2}{d_{11}d_{22}-d_{12}d_{21}} & \frac{d_{22}gm_2r_2-d_{12}m_2r_2}{d_{11}d_{22}-d_{12}d_{21}} & 0 & 0 \\ 0 & 0 & 0 & 1 \\ \frac{d_{21}g[r_1(m_1+m_2)+m_2r_2]-d_{11}m_2r_2}{d_{12}d_{21}-d_{11}d_{22}} & \frac{d_{21}gm_2r_2-d_{11}m_2r_2}{d_{12}d_{21}-d_{11}d_{22}} & 0 & 0 \end{bmatrix} \begin{bmatrix} x_1 \\ x_2 \\ x_3 \\ x_4 \end{bmatrix} + \begin{bmatrix} 0 & 0 \\ \frac{d_{22}}{d_{11}d_{22}-d_{12}d_{21}} & \frac{-d_{12}}{d_{11}d_{22}-d_{12}d_{21}} \\ 0 & 0 \\ \frac{d_{21}}{d_{12}d_{21}-d_{11}d_{22}} & \frac{-d_{11}}{d_{12}d_{21}-d_{11}d_{22}} \end{bmatrix} \begin{bmatrix} T_1 \\ T_2 \end{bmatrix} \quad (17)$$

Table.1. Consider typical parameters for two link planar arm as[3]

Symbol	Parameters	Value	Unit
m_1	Mass of link 1	1.4	kg
m_2	Mass of link 2	1.1	kg
r_1	Length of link 1	0.3	m
r_2	Length of link 2	0.33	m
I_1	Movement of inertia of link1	0.025	kg m ²
I_2	Movement of inertia of link 2	0.045	kg m ²

2.3. Linear Quadratic Regulator

We deal with the closed loop optimal control of linear system with quadratic performance index. This leads to the linear quadratic regulator system dealing with state regulation, output regulation and state tracking.

Problem Formulation:

Consider a linear, time varying system

$$\dot{x}(t) = Ax(t) + Bu(t) \quad (18)$$

$$y(t) = Cx(t) \quad (19)$$

with a Performance Index (PI)

$$J(u(t)) = J(x(t_0), u(t), t_0)$$

$$J(u(t)) = \frac{1}{2} x'(t_f)F(t_f)x(t_f) + \frac{1}{2} \int_{t_0}^{t_f} [x'(t)Q(t)x(t) + u'(t)R(t)u(t)]dt \quad (20)$$

Where $x(t)$ is n^{th} state vector, $y(t)$ is m^{th} output vector, $u(t)$ is r^{th} control vector. $A(t)$ is $n \times n$ state matrix, $B(t)$ is $n \times r$ control matrix and $C(t)$ is $m \times n$ output matrix. We assume that the control $u(t)$ is unconstrained, $0 < m \leq r \ll n$ and all the states and/or outputs are measurable. Under these assumptions, we will find that the optimal control $u(t)$ is a function of the state $x(t)$ or output $y(t)$. Here our objective is to keep the state $x(t)$ near zero, then we call it state regulator system. In other words, the objective is to obtain a control law $u(t)$ which takes the plant described by (18) and (19) from a nonzero state to zero state.

Let us consider the various matrices in the cost functional (20) and their implications.

- The Error weighted matrix $Q(t)$: In order to keep the error $e(t)$ small and error squared non-negative, the integral of the expression $\frac{1}{2} e'(t)Q(t)e(t)$ must be positive. Thus the matrix $Q(t)$ must be positive semi-definite.
- The Control weighted matrix $R(t)$: The quadratic nature of the control cost expression $\frac{1}{2} u'(t)R(t)u(t)$ indicates that one has to pay higher cost for larger control effort. Since the cost of the control has to be a positive quantity, the matrix $R(t)$ should be positive definite.
- The Terminal cost weighted matrix $F(t_f)$: The main purpose of this term is to ensure that the error $e(t)$ at the final time t_f is as small as possible. To guarantee this, the corresponding matrix $F(t_f)$ should be positive semi-definite.

Further, we assume that the weighted matrices $Q(t)$, $R(t)$ and $F(t_f)$ are symmetric.

- Infinite final time: When the final time t_f is infinity, the terminal cost term involving $F(t_f)$ does not provide any realistic sense since we are always interested in the solutions over finite time. Hence, $F(t_f)$ must be zero.

2.4. Position Control of Human Arm, Shoulder Angle (θ_1), elbow angle (θ_2)

Consider the table I. Parameters, substitute values into equation (20) and initial condition as

$$q_{10} = \frac{\pi}{2}, q_{20} = 0 \text{ then we get the linearized model as } \begin{bmatrix} \dot{x}_1 \\ \dot{x}_2 \\ \dot{x}_3 \\ \dot{x}_4 \end{bmatrix} = \begin{bmatrix} 0 & 1 & 0 & 0 \\ 32.79 & 0 & 6.625 & 0 \\ 0 & 0 & 0 & 1 \\ -67.38 & 0 & -8.92 & 0 \end{bmatrix} \begin{bmatrix} x_1 \\ x_2 \\ x_3 \\ x_4 \end{bmatrix} + \begin{bmatrix} 0 & 0 \\ 4.65 & -7.94 \\ 0 & 0 \\ -7.94 & 27.27 \end{bmatrix} \begin{bmatrix} T_1 \\ T_2 \end{bmatrix}$$

$$C = \begin{bmatrix} 1 & 0 & 0 & 0 \\ 0 & 1 & 0 & 0 \\ 0 & 0 & 1 & 0 \\ 0 & 0 & 0 & 1 \end{bmatrix} \tag{21}$$

The state vector \dot{x} has two joint angles and two angular velocities for two link arm dynamics. The state feedback system minimizes the performance index equation (20).

The Control Law is $u = T = -Kx$ (22)

The LQ gain matrix K is calculated by

$$K = R^{-1}B^T P \tag{23}$$

Where P is definite positive solution of Riccati equation:

$$A^T P + PA - PBR^{-1}B^T P + Q = 0 \tag{24}$$

Q, R are arbitrary weighting matrices of performance index. Outputs from the state-space dynamics feed through LQ gains to provide joint angles θ_1, θ_2 .

2.5. Simulation Results of Two link planar Arm Model

The simulation results of planar arm model by using Linear Quadratic Regulator given below.

Optimal gain matrix, $K = \begin{bmatrix} 11.65 & 3.848 & 2.85 & 0.49 \\ 0.23 & 0.466 & 2.76 & 2.42 \end{bmatrix}$

Solution of Riccati equation, $P = \begin{bmatrix} 23.68 & 5.104 & 5.55 & 1.46 \\ 5.104 & 1.704 & 1.56 & 0.51 \\ 5.55 & 1.56 & 6.84 & 0.55 \\ 1.46 & 0.51 & 0.55 & 0.23 \end{bmatrix}$

Eigen values of $(A-BK) = [-66.76 \quad -6.44 \quad -2.106 \quad -1.013]$

Eigen values of $P = [0.074 \quad 0.6484 \quad 5.176 \quad 26.56]$

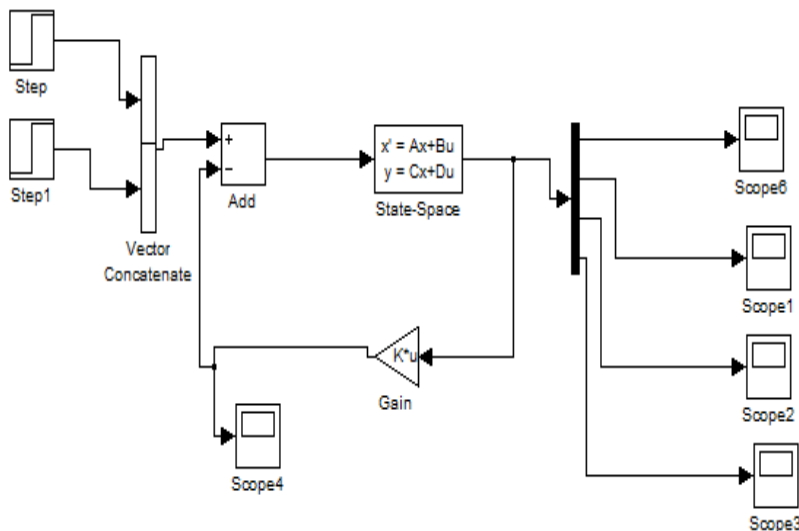
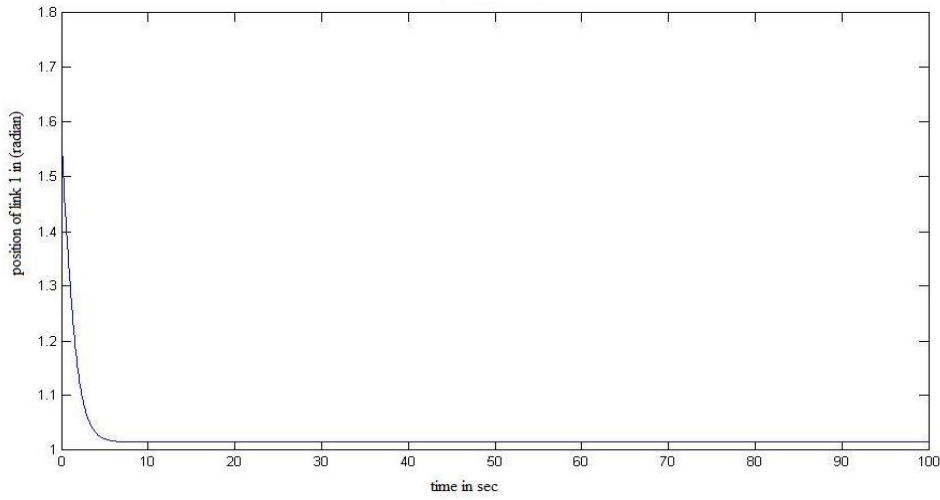
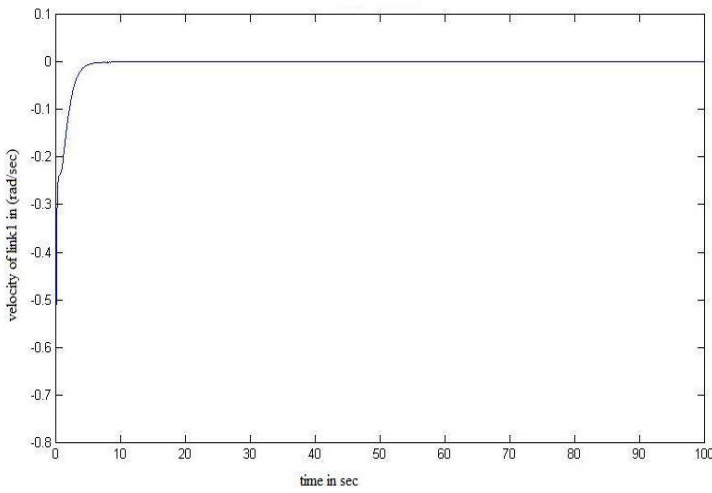

Fig. 2.LQR Simulation Basic Block Diagram.



Fig(a)



Fig(b)

Fig.3.LQR State Tracking, Position and Velocity of Link 1 Shown in Fig (a) and Fig (b). Initially The Position is at 1.55 radian when a Step Input of 1 radian is applied, the State track with Steady State Error of 2%.

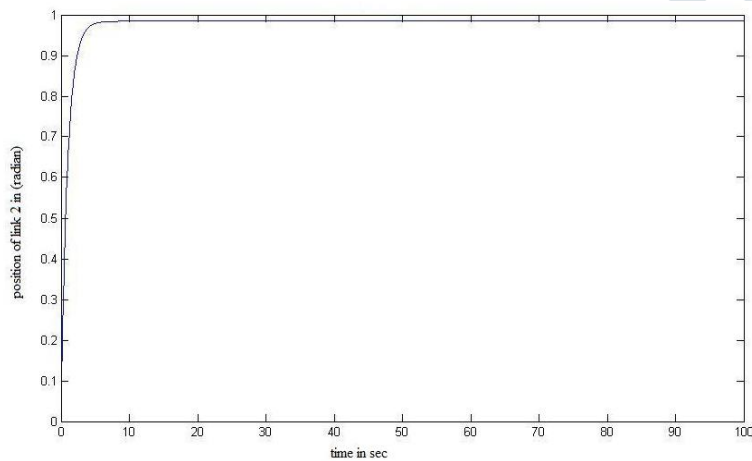

Fig. (c).

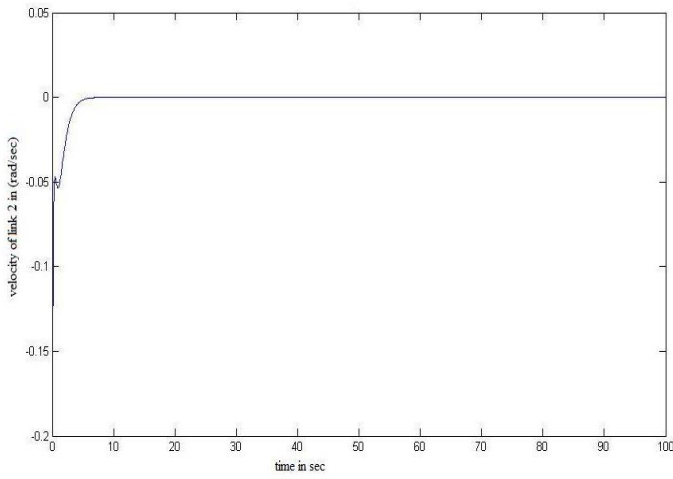

Fig. (d).

Fig.4. LQR State Tracking, Position and Velocity of Link 2 Shown in Fig (c) and Fig (d). Initially the State is at 0.15 radian and it tracks the applied Step Input of 1 radian with 2% Steady State Error.

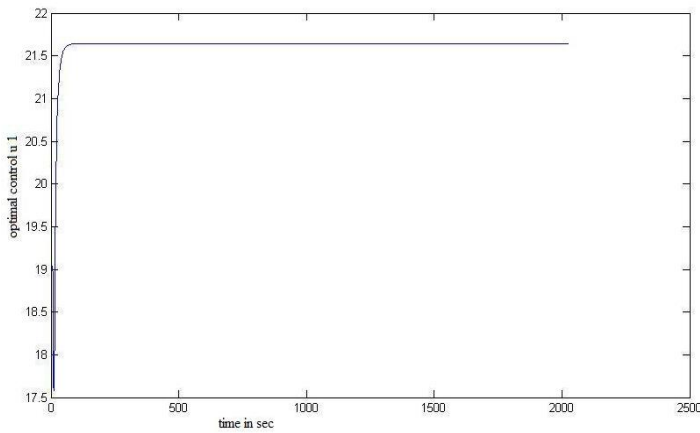

Fig. (e).

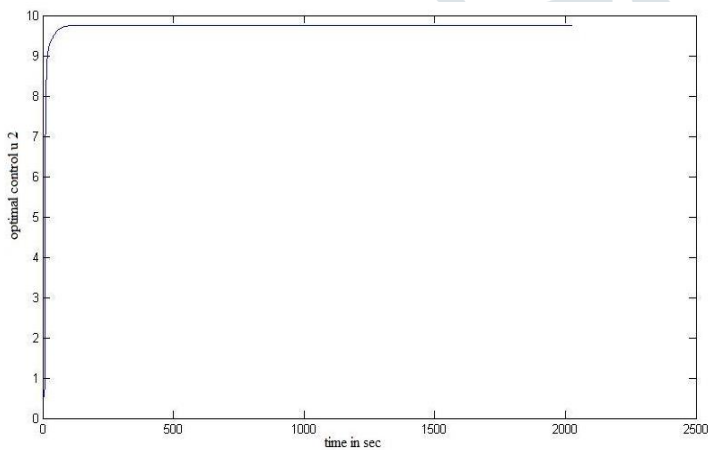

Fig. (f).

Fig.5. Optimal Control, u of Link 1 and Link 2 Shown in Fig (e) and Fig (f), which drives the State to desired State.

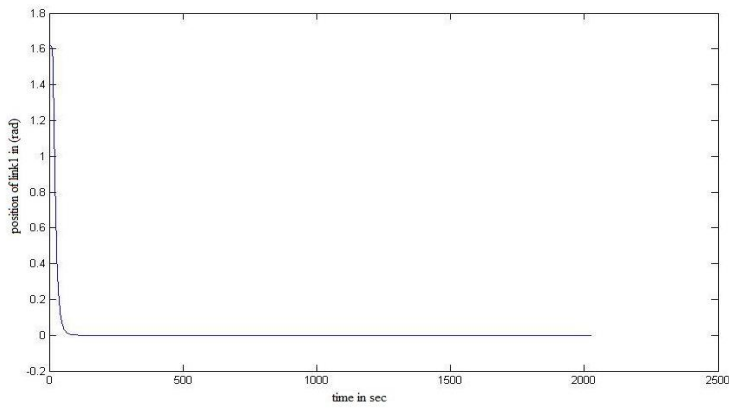

Fig. (g).

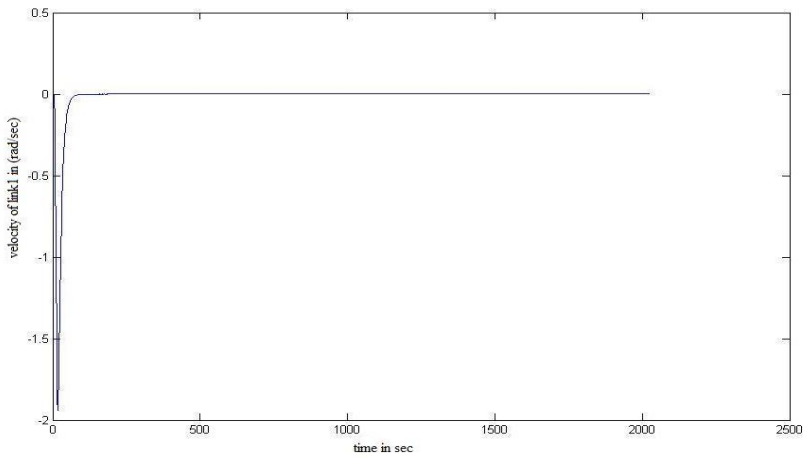

Fig. (h).

Fig.6. LQR State Control, Position and Velocity of Link 1 shown in Fig (g) and Fig (h). Initially the State is at 1.16 radian and it reaches Zero State.

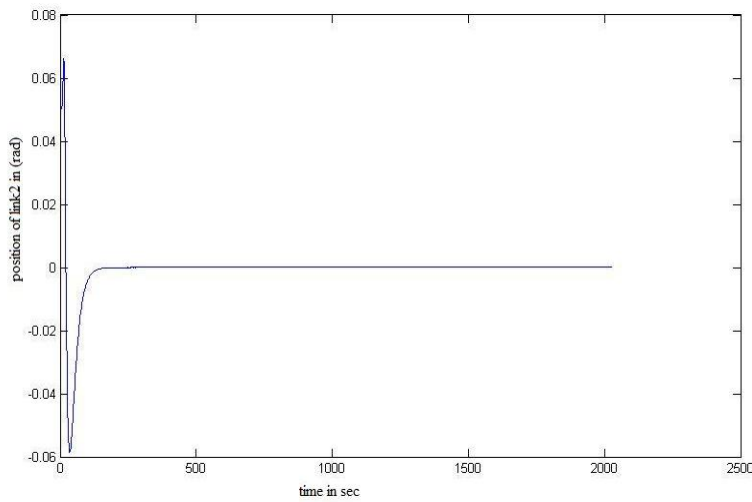

Fig. (i).

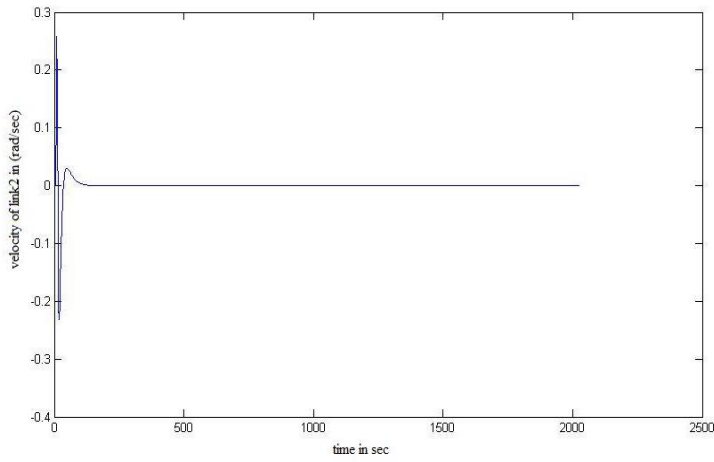

Fig. (j).

Fig.7. LQR State Control, Position and Velocity of Link 2 Shown Fig (i) and Fig (j). Initially the State is at 0.05radian and reaches to Zero State.

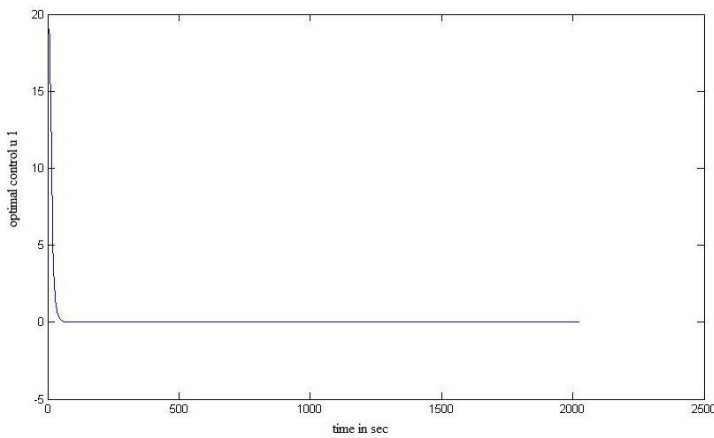

Fig. (k).

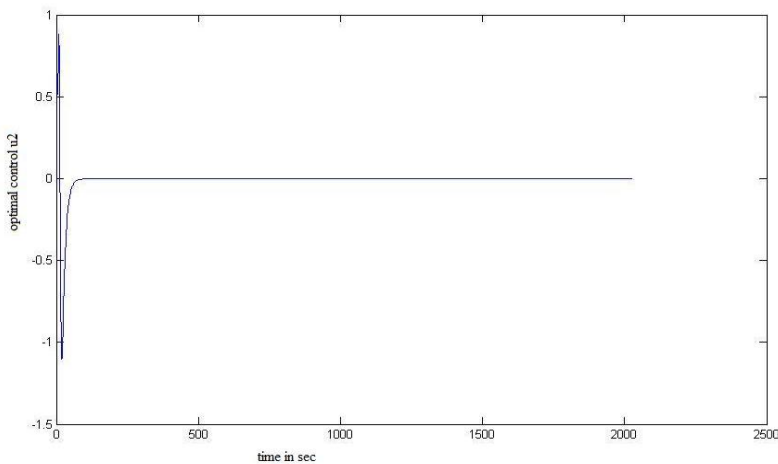

Fig. (l).

Fig.8. LQR Optimal Control, u of Link 1 and Link 2 shown in Fig(k) and Fig(l).

3. Conclusion: The optimal gain matrix, K, designed such that initially, the position of link 1 is at 1.55 radian when a step input of 1 radian is applied, the state tracks with steady state Error of 2%. For link 2 the state is at 0.15radian and it tracks the applied step input of 1 radian with 2% steady state error. The corresponding Optimal Control, u of Link 1 and Link 2 shown above which drives the state to

desired state, indicates optimal state tracking .Also LQR State Control, Position and Velocity of Link 1 and Link 2 obtained such that for link 1 initially the state is at 1.16 radian and it reaches Zero state, for Link 2 initially the state is at 0.05radian and reaches to Zero State, indicates optimal state control.

- [1] Kaveh Hassani, Won-Sook Lee, “Optimal tuning of Linear Quadratic Regulators using Quantum particle swarm optimization”, Proceedings of the Int.Conference of control, dynamics systems, and Robotics, OTTAWA, Ontario, Canada, May 2014.
- [2] J.A.Tenreiro Machado, J.L.Martins de Carvalho, and Alexanra M.S.F.Galhano, “ Analysis of robot dynamics and compensation using classical and computed torque techniques ”, IEEE Transactions on Education , vol.36, no.4, Nov.1993.
- [3] Weiwei Li, “optimal Control for Biological Movement Systems University of California, San Diego, 2006.
- [4] Musa Mailah , H.Jahanbadi, MZMZain, and G.Priyanadako; “Modelling and control of a human like arm incorporating muscle models”Proc.IMechE partC; Journal of mechanical engineering science,vol.223,pp.1569-1577, July 2008.

About Author:



¹**Mr.Mohan Bukya**, is currently working as Assistant Professor in the Dept. of EEE, He has completed B. Tech from Kakatiya University in 2008. He has completed M. Tech in Control Systems specialization at IIT Kharagpur in 2011.He has 9-years teaching and research experience. He has published 05- international research papers. His research area interest in Control Systems, Hybrid Electric Vehicle and Renewable Energy Integration.



²**K. Naresh**, is currently working as HOD in Dept. of EEE ,Usha Rama College of Engineering and Technology. He has completed B. Tech from VIIT in 2006. He has completed M. Tech in Control Systems specialization from IIT Kharagpur in 2011 and Pursuing Ph.D from JNTUA Ananthapuram. He has 12- years teaching and research experience. He has published 18- international research papers. He has written three monographs. His research area interest in Control systems, Power systems and Renewable energy control.