

Advantages of using PVC material for Ventilation Ducts over Conventional G.I. Ducts.

Laxman Mandal¹, Ganesh Satve², Shadab Khan³, Eesa Rakhange⁴, Aslam Hirani⁵

^{1, 2, 3, 4, 5}Department of Mechanical Engineering, Anjuman-I-Islam's Kalsekar Technical Campus, New Panvel, India.

Abstract– In VRF systems Ventilation ducting is used for fresh air supply. Generally these ducts are made of Galvanized Iron. This article describes the implementation of PVC as a material for ventilation ducts instead of common GI ducts for a commercial office located in Pune, Maharashtra. Duct designing and calculations are done with the help of Computer based software applications and standard data. PVC ducting is efficient, low power and Cost effective alternative for the conventional ducting systems.

Keywords – VRF system, HVAC system, Ventilation, Duct, Software applications, Cost.

I. INTRODUCTION

A Variable Refrigerant Flow System is silent, precise and highly energy efficient HVAC technology, best for individualized comfort control. But the system has no provision for outside air supply to the air conditioned space. The ventilation air is delivered to the occupied space through a duct.

G.I ducts are most commonly used for the ventilation purpose and this paper suggests PVC for duct material as it has many advantages over G.I ducts. PVC is light in weight and smooth than G.I. Its absolute roughness is only 10% of roughness of galvanized iron. Thus it has less pressure drop. A PVC duct has around 33% less pressure drop per 100ft of duct length. Therefore the power requirement for the fan unit is also low. Therefore the PVC ducts become very cost effective and energy efficient solution over conventional ducting.

Ducts are designed by either manual calculation method or with the help of software application. Manual calculation is based on standard data or charts (e.g. duct friction chart). For the current office layout the ducts are designed using McQuay DuctSizer 6.4. Pressure calculations are done using ASHRAE Duct Fitting Database 6.0. Total pressure drop is required to determine the thickness and Fan selection. The detailed procedure is shown in subsequent sections.

Office layout for Ducting:

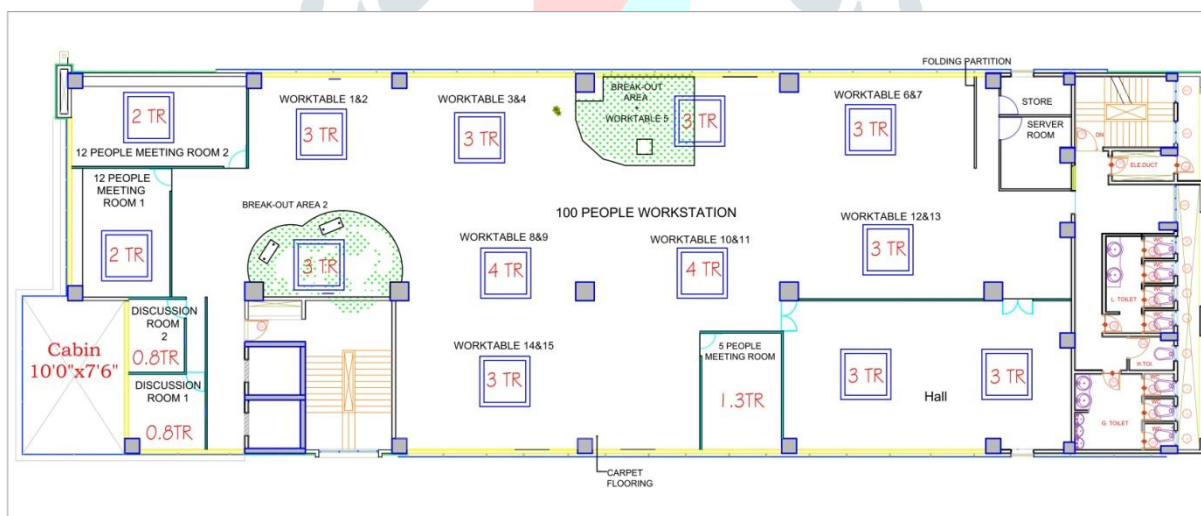

Fig.1. Office layout

II. DESIGNING OF DUCTS

Designing of ducts includes different shapes of ducts as rectangular ducts, circular ducts, oval ducts. In this paper design of ducts is obtained by circular ducts by using PVC. For designing of ducts different methods are used [1][2] as flows:

1. Equal friction method.
2. Velocity reduction method.
3. Static regain method.

In these methods the calculations are either done manually using standard friction charts or by using Duct Sizer application as discussed below:

A. Using Friction chart [1][2]:

Horizontal lines describes the flow rate or air quantity in (CFM) cubic feet per minute

Vertical lines depicts the head loss in (in WC/100 ft) inches of water column per 100 feet.

Inclined lines show the velocity in (fpm) feet per minute and equivalent diameter in inches. It can be seen easily in figure 2.

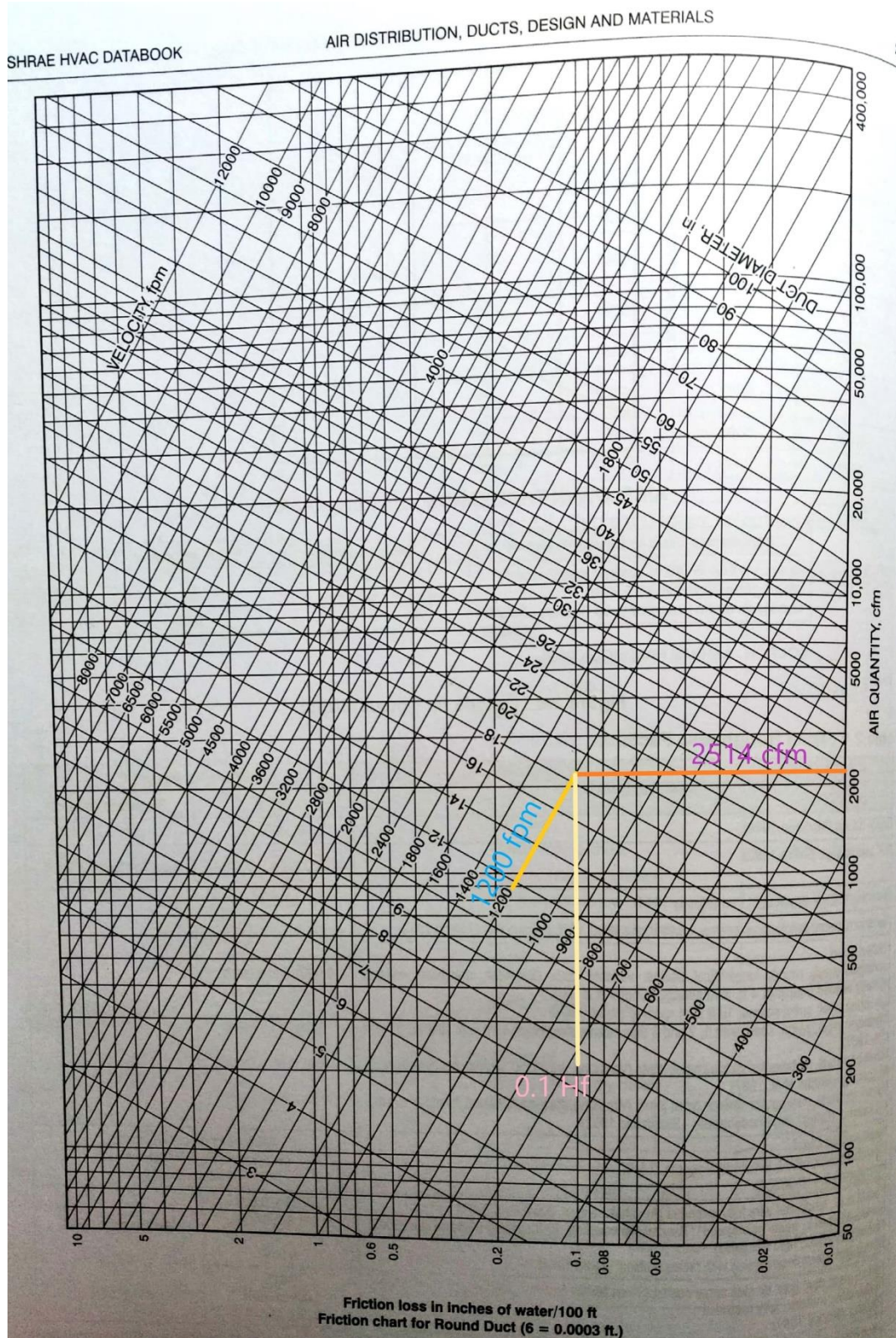

Fig.2. Friction Chart

Figure 2 shows the friction chart which evaluates the value of head loss as 0.1 in WC/100 ft by plotting the value of air quantity is equal to 2514 CFM as total flow rate and velocity equal to 1200fpm for office building [1][2][10].

B. Using Duct Sizer application:

To overcome some difficulties while plotting friction chart and for time saving, for removing error and for increasing accuracy, Duct Sizer application is used. It is simple to use as compared to friction chart

Duct Sizer application work on algorithm which gives the approximate value as we can get from the friction chart

Different parameters are required for designing by using duct sizer are as follows:

- Flow rate in cubic feet per minute (CFM): Total flow rate is equal to 2514 CFM
- For private offices duct velocity is equal 1200 feet per minute (fpm) [10]
- Equivalent Diameter of ducts in inches

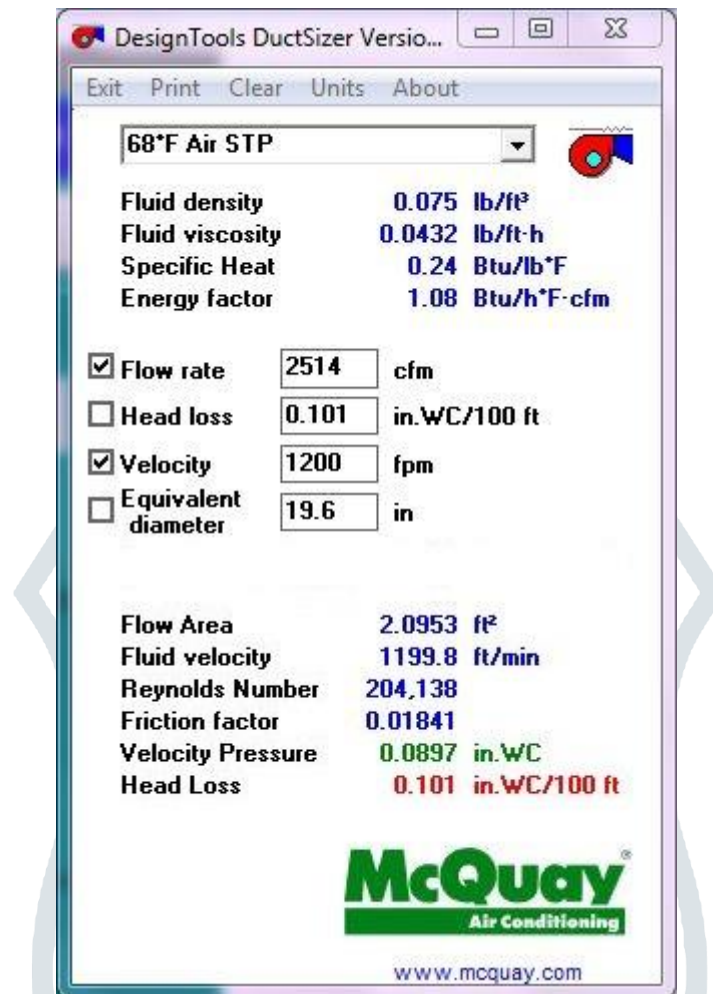

Fig.3. Calculation of Head loss and eq. Dia by using McQuay DuctSizer 6.4

From figure 3, By using total flow rate equal to 2514 CFM and velocity equal to 1200 fpm and we got head loss as 0.101 inch of water per 100 feet (in WC/100 ft)

It can be determined by using head loss as 0.101 in WC/100ft as constant value got from previous evaluation and 15% of CFM corresponding to each indoor unit.

For example,

- 2TR requires 800 CFM of air supply
- Therefore, 15% of 800cfm is equal to 120cfm which is required for ducting respectively.

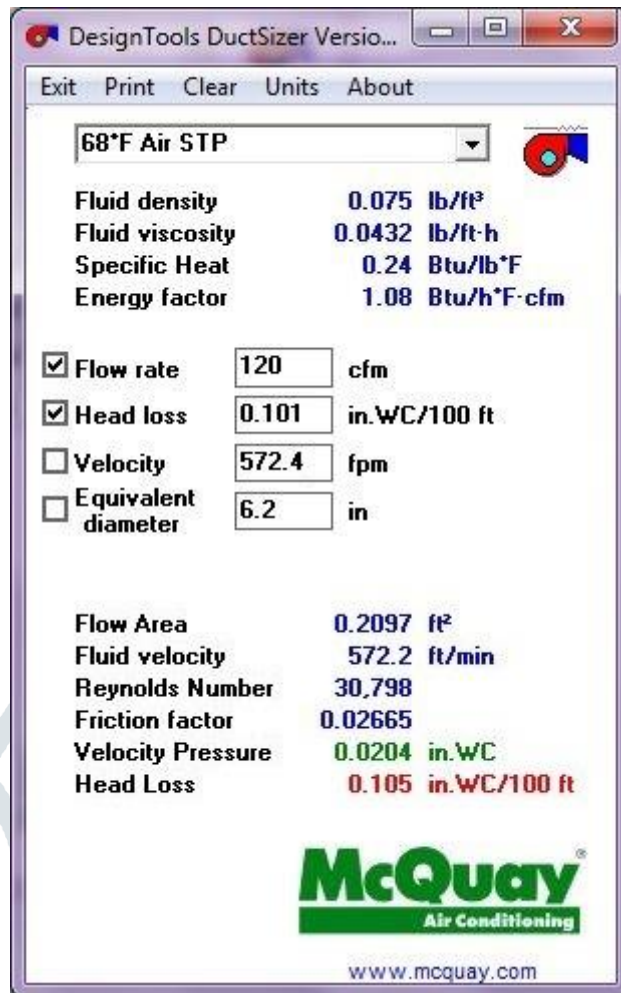

Fig.4. Calculation of eq. Dia with help of previous head loss value

From figure 4, we got equivalent diameter of specific duct equal to 6.2 inch and the method used as equal friction method and same is used to find further ducts diameters.

Similarly remaining ducts diameters are shown in the below diagram.

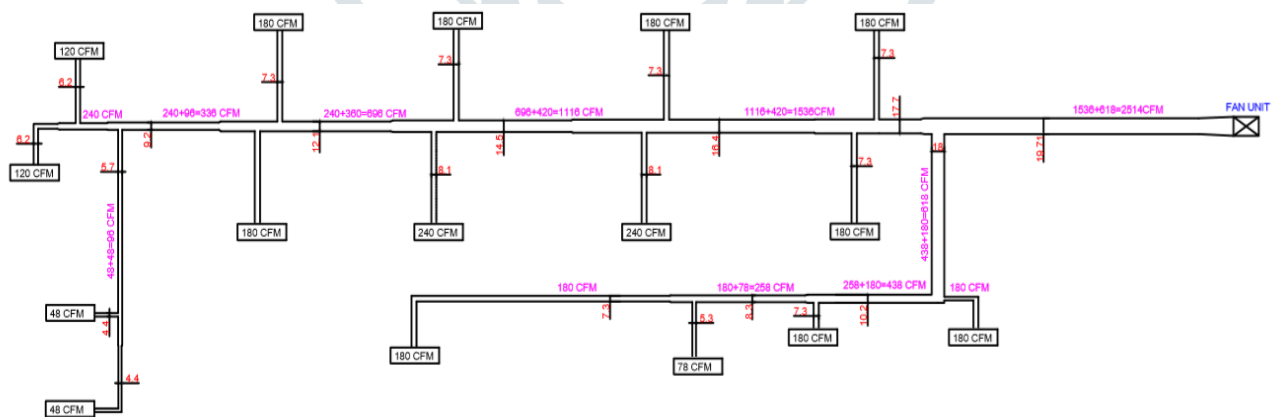

Fig.5. Duct layout (Diameters)

III. CALCULATION OF PRESSURE LOSS

In duct designing Pressure calculation refers to calculation of duct internal resistance to the flow of air. That is the pressure required for efficient flow of air through the duct.

There are mainly three types of pressure losses calculated while designing the ducts [1]

1. Static pressure: It is resistance provided by the duct walls for the flow of air, which needs to overcome to make the flow possible.

2. Velocity pressure: It is the pressure developed by the flowing fluid. For calculation purpose it can be referred as pressure required to flow the air with required velocity.
3. Total pressure: It is the Sum of static and velocity pressure. This is the total pressure generated by the air when it flows through the duct.

For a particular path the pressure is estimated by adding all the pressures at every sections of the path. [1]

For the calculation of total pressure loss and fan selection the path with highest pressure loss is taken into the consideration and that path is called as 'Critical Path'. It is either the longest path for fluid flow or a path with maximum duct fittings or bends to yield maximum resistance (pressure). [1][2]

Types of pressure losses (Calculated using ASHRAE Duct fitting database 6.0) [1]

1. Duct fitting losses;
 - i. Straight duct friction loss

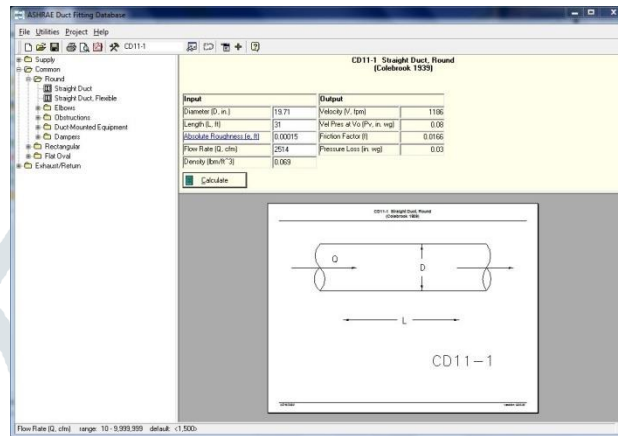

Fig.6. Pressure loss for straight duct

- ii. Branching friction loss

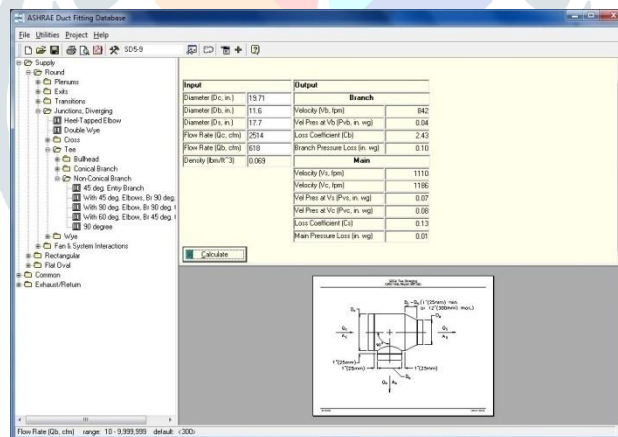

Fig.7. Pressure loss for Branching

- iii. Elbow

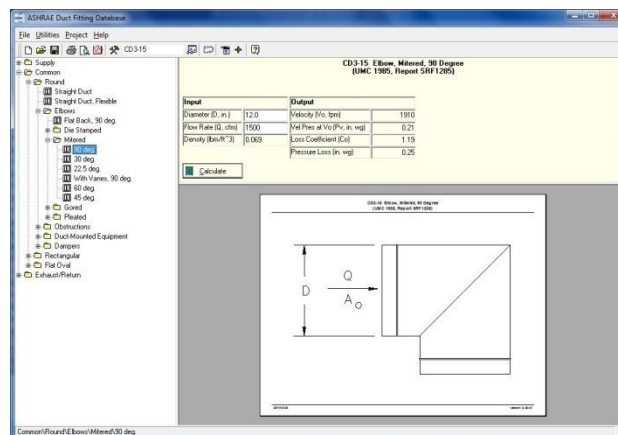

Fig.8. Pressure loss in elbow joint

2. Equipment losses (Determined directly from manufactures catalogs) [7][8]
 - i. Air Filters (AAFL catalogue) [7]
 - ii. Volume control dampers (VFCD Catalogue) [8]

A. Duct System layout

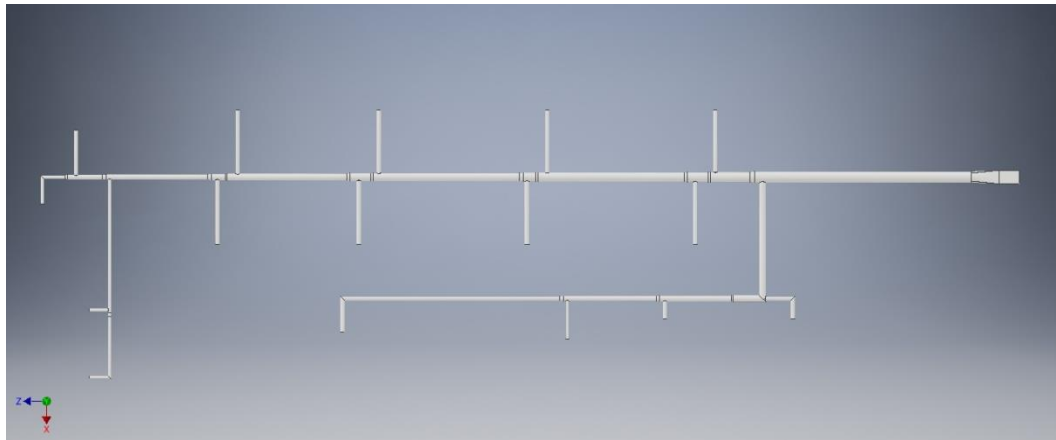

Fig.9. Ducting layout for given office

B. Critical Path for Pressure calculation [1][2]

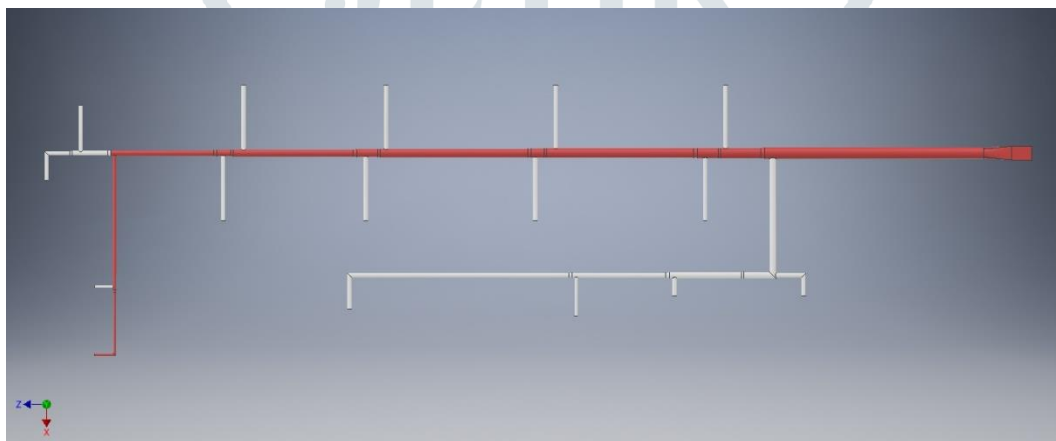

Fig.10. Critical path

C. Total pressure:

The pressure for this path is calculated with help of ASHRAE Duct fitting Database 6.0. [1] the result is:

For the Critical path,

Total pressure = 1.89 inches of WC. = 472 Pa

IV. ESTIMATION OF DUCT THICKNESS

Thickness of the duct is directly estimated from IS - 655 / 2006 [6]

Table 6 Thickness of Sheet for Rigid Polyvinyl Chloride Duct

(Clause 6.2.1)

| Classification of Duct by Pressure (1) | Low Pressure Duct and Medium Pressure Duct | High Pressure Duct Pa | | Thickness of Sheet, Min mm (5) |
|---|--|---------------------------------|---------------------------------|-----------------------------------|
| | $p \leq 1\,000$ (2) | $1\,000 < p \leq 1\,500$ (3) | $1\,500 < p \leq 2\,000$ (4) | |
| Long side of duct | $l \leq 500$ | $l \leq 500$ | — | 3 |
| | $500 < l \leq 1\,000$ | — | $l \leq 500$ | 4 |
| | $1\,000 < l \leq 2\,000$ | $500 < l \leq 2\,000$ | $500 < l \leq 2\,000$ | 5 |
| | $2\,000 < l$ | $2\,000 < l$ | $2\,000 < l$ | 6 |

Fig.11. IS standard thickness chart for PVC

For 472 Pa internal pressure, Thickness = 3mm

V. FAN SELECTION

Fan is selected according to pressure required in the duct and the total flow rate. Fans are selected according to Fan curves. Fan curves are plotted as Pressure Vs Flow rate. [1][2]

Properties which are determined from fan curve [1][2][9]

- i. Fan speed
- ii. Pitch angle
- iii. Motor Power

Selection of Fan for the Current duct layout:

- Pressure = 472 Pa
- Air flow rate = 2514 CFM
= 4271 m³/hr
= 1.19 m³/s
- On the fan curve vertical axis shows the pressure and horizontal axis is for flow rate [9]. Above values are plotted on Fan curve to determine the required fan properties.



Performance Curve

AXV 500-7, 50 Hz

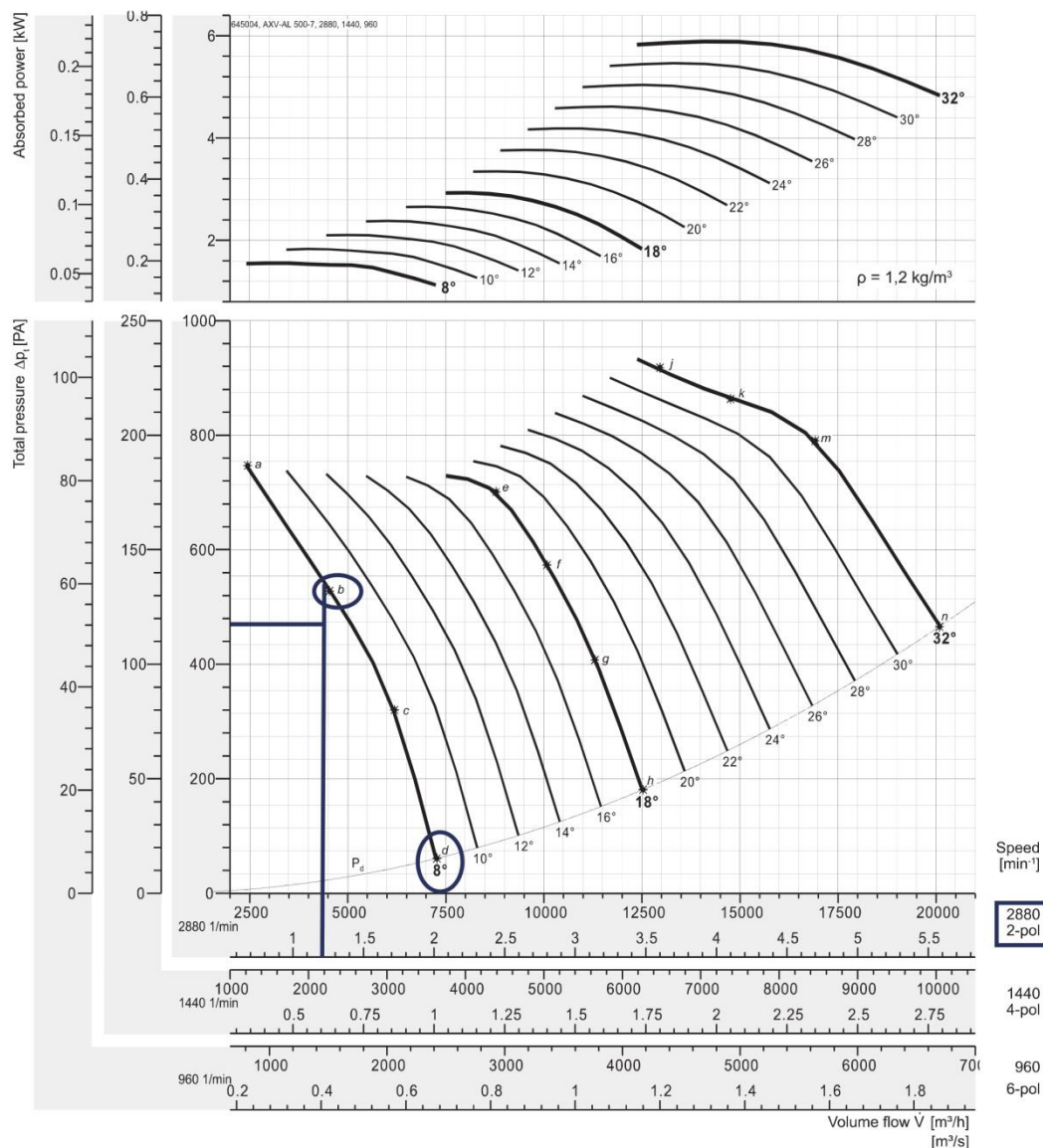

Peak absorbed power [kW]

| n [min ⁻¹] | Pitch angle [°] | | | | | | | | | | | | | | | | |
|---------------------------|-----------------|-------|-------|-------|-------|-------|-------|-------|-------|-------|-------|-------|-------|----|----|----|----|
| | 8 | 10 | 12 | 14 | 16 | 18 | 20 | 22 | 24 | 26 | 28 | 30 | 32 | 34 | 36 | 38 | 40 |
| 960 motor | 0,058 | 0,068 | 0,078 | 0,088 | 0,098 | 0,108 | 0,124 | 0,141 | 0,155 | 0,171 | 0,187 | 0,202 | 0,218 | - | - | - | - |
| 1440 motor | 0,194 | 0,228 | 0,262 | 0,297 | 0,331 | 0,366 | 0,419 | 0,471 | 0,524 | 0,577 | 0,630 | 0,683 | 0,736 | - | - | - | - |
| 2880 motor | 1,55 | 1,83 | 2,10 | 2,37 | 2,65 | 2,93 | 3,35 | 3,77 | 4,19 | 4,61 | 5,04 | 5,46 | 5,89 | - | - | - | - |
| | 2,2 | | | | | | | 4 | 5,5 | | | | 7,5 | | | | |

Fig.12. Fan selection using fan curve

Fan properties selected from Fan Curve [9]

- i. Fan Speed: 2880 rpm
- ii. Pitch angle: 8°
- iii. Motor Power: 1.55 kW

VI.COST COMPARISON

Initial cost and running cost is to be considered while cost comparison. Material cost, cost of fan-motor and damper is considered to be initial cost. Energy consumption, maintenance and many other are to be considered in running cost.

Figure 13 represent the mass of PVC material required for ducting which is 885.843 lb.

As, 1 lb = 0.453592 kg So, 885.83 lb = 401.81 kg.

Considering standard rate 1kg PVC material to be 72 Rs.\kg [12] (finished product)

The total cost of material accounts for: $401.81 * 72 = 28,930.32$ Rs.

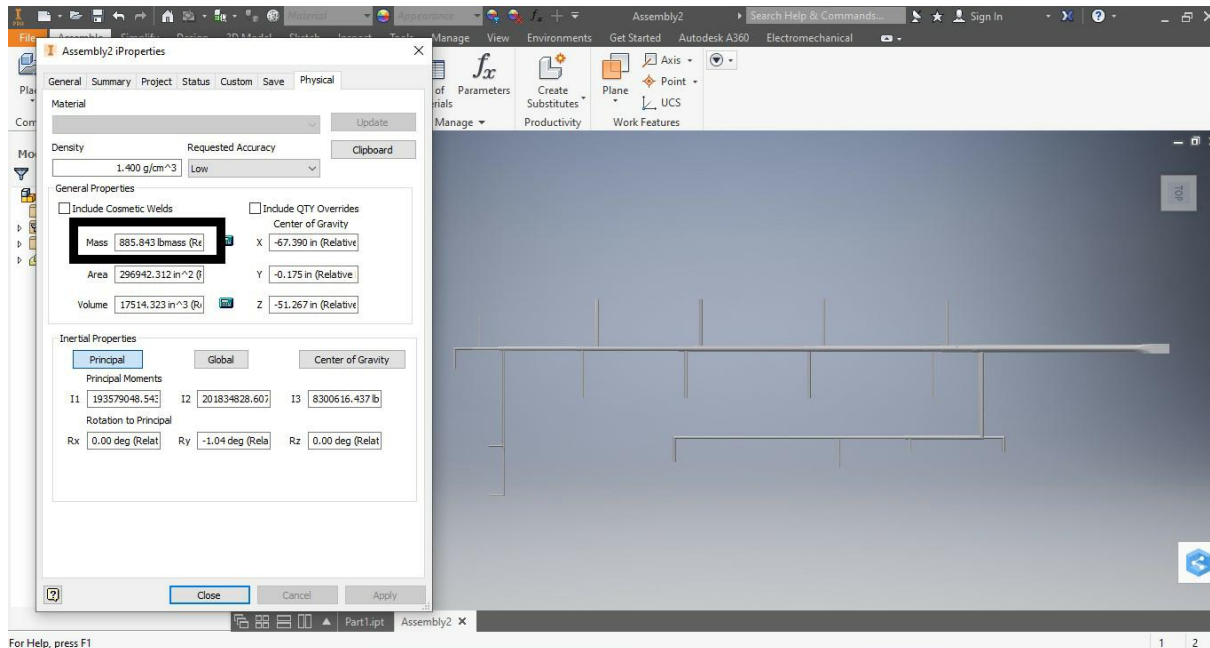

Fig.13. Mass estimation of PVC ducting using Inventor Software

Figure 14 represent the mass of GI material required for ducting which is 1728.94 lb, which is equivalent to 784.23 kg. When considered standard rate of 1 kg of GI to be 70 Rs\kg [13].

Therefore, total cost is $784.23 * 70 = 54,896.1$ Rs.

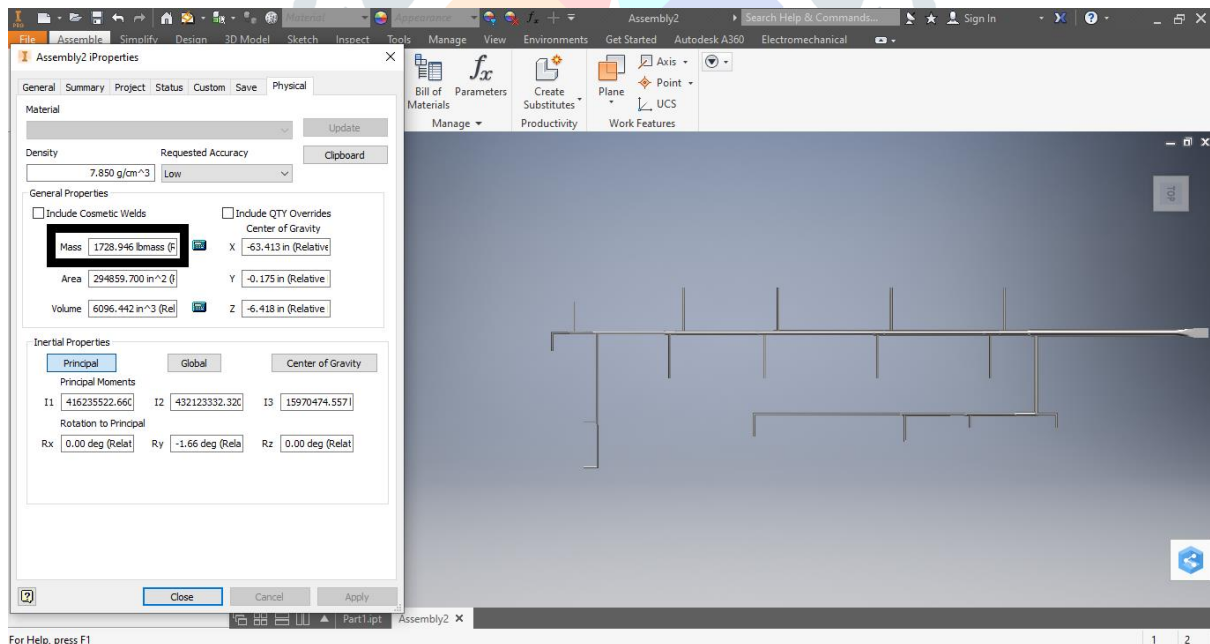

Fig.14. Mass estimation of G.I ducting using Inventor Software

Savings in rupees (for material) = $54,896.1 - 28,930.32 = 25,965.78$ Rs.

While considering fan-motor cost there is no substantial difference in fan size so the cost also don't differ a lot as mentioned in Table III – motor specification for PCV and GI. Where the cost 1.55 kW motor, required in PVC ducting is 13,037 Rs. [17], conversely cost of 2.2 kW motor, required in GI ducting is 13,958.2 Rs. [18]

Saving in rupees (fan-motor) = $13958.2 - 13037 = 921.2$ Rs.

Other costs which are present are shown in Table I.

TABLE I
COST ELEMENTS PRESENT IN PVC OR GI DUCT SYSTEMS [1][2][11-16]

| Material | PVC | GI |
|------------------------|---------|---------|
| Fasteners (nut & bolt) | Absent | Present |
| Adhesive | Present | Absent |
| Thermal insulation | Absent | Present |

As we can see from the above table that ducting of PVC requires less equipment as compared to GI ducting.

For a rough estimation consider 3 kg of adhesive will be required (advised by normal contractor), cost per kg of adhesive is 140 Rs/kg [14] so the total cost accumulates to $3 \times 140 = 420$ Rs.

Now let's assume that total 10 kg of nuts and bolts are required in ducting per kg cost of nuts and bolts are 55 Rs./kg [15]. The cost of nuts and bolts would be $55 \times 5 = 275$ Rs.

Thermal insulation is available per sq. ft and the price is 20 Rs./sq. ft [16]. From figure 15 total surface area for GI ducting is 294859.7 sq. inch i.e. 2047.63 sq. ft, so the cost for insulation comes to $2047.63 \times 20 = 40,940$ Rs.

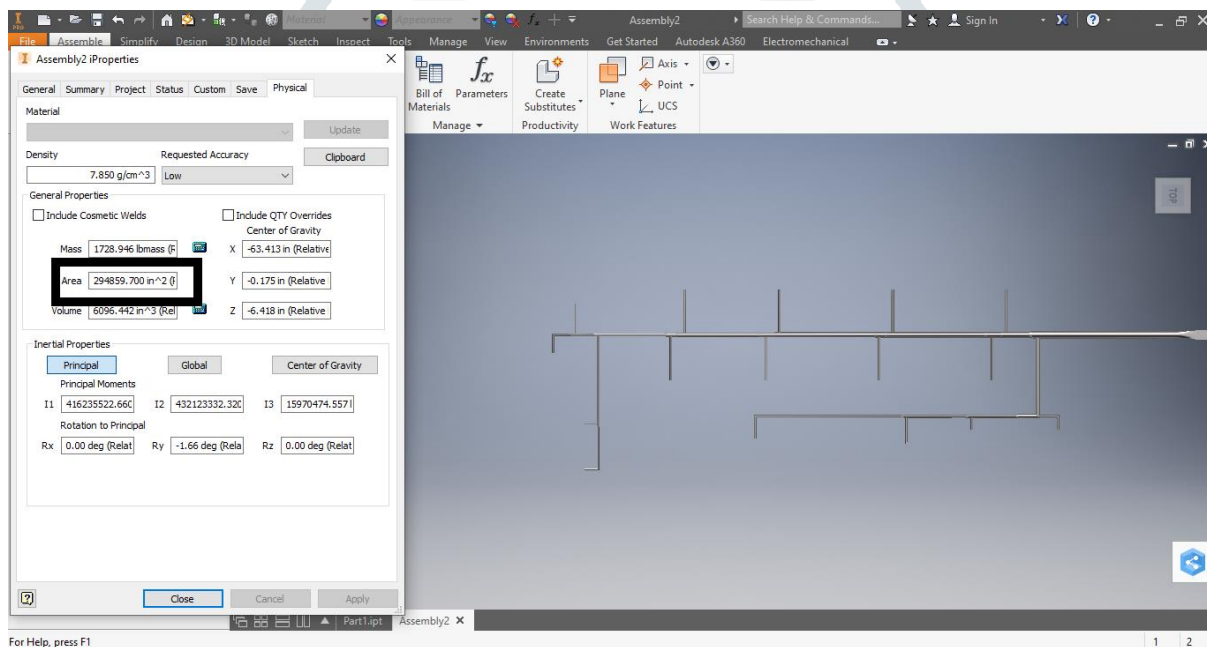

Fig.15. Surface area of G.I ducting using Inventor Software

TABLE II
COST COMPARISONS OF PVC DUCTING & G.I DUCTING [12-18]

| Items | GI Ducting (Rs) | PVC Ducting (Rs) | Difference (Rs) |
|------------------------|-----------------|------------------|-----------------|
| Material | 54,896.1 | 28,930.32 | 25,965.78 |
| Fan-motor | 13,958.2 | 13,037 | 921.2 |
| Adhesive | - | 420 | - 420 |
| Fasteners (nut & bolt) | 275 | - | 275 |
| Thermal insulation | 40,940 | - | 40,940 |
| Total: | | | 67681.98 |

From Table II we get total saving in initial cost, there many other factor such as labour and time i.e. not much skilled labour is required for ducting of PVC compared to GI ducting, also the time required for PVC ducting is less.

Consider running cost, the cost associated with electricity consumption and maintenance of ducts.

Motor installed in both systems has power capacity as follows:

Motor installed in PVC ducting consumes a power of 1.5 kW compared to 2.2 kW required in GI ducting. Average per unit watt rate in different regions of India has been taken from [5] PHD chamber of commerce and industry, which is 9.85 Rs. /kW for Maharashtra.

Cost in rupees:

$$\text{Cost per day} = \text{per unit rate} * \text{Power consumed (kW)} * \text{no. of hours in a day}$$

$$\text{Cost in PVC ducting} = 9.85 * 1.5 * 12 = 177.3 \text{ Rs. \day}$$

$$\text{Cost GI ducting} = 9.85 * 2.2 * 12 = 252.16 \text{ Rs. \day}$$

Similarly it can be calculated for different time period. Graphically the cost comparison is shown below:

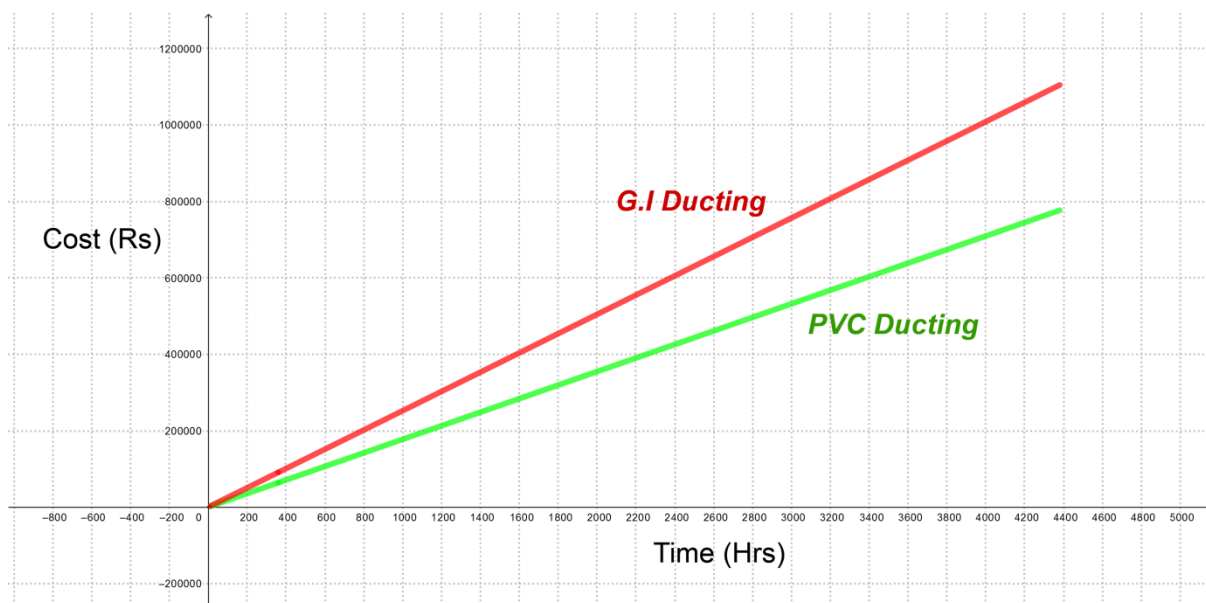

Fig.16. Power consumption cost vs. Time graph

VII. PHYSICAL PROPERTIES

Availability of shape and size: PVC pipes are easily available as compared to GI pipes for ducting.

Weight: PVC pipes are lighter than GI pipes and are easy for installation.

Cost: Cost of PVC Pipes are comparatively lower than GI pipes as already proved above [11].

G.I pipes are not always suitable for duct work due to its corrosive, heavy weight, inflexible properties as well as high cost. Because of these reasons use of PVC pipes may solve the above problems [3].

TABLE III
COMPARISON BETWEEN PVC DUCTING AND G.I DUCTING

| Sr. No. | Particulars | GI ducting | PVC ducting |
|---------|-----------------------------------|-------------------------|-------------------------|
| 1 | Roughness | 0.003 ft | 0.00015 ft |
| 2 | Pressure loss | 0.12 in WC/ 100ft | 0.08 in WC/ 100ft |
| 3 | System Pressure | 710 Pa | 472 Pa |
| 4 | % Pressure loss | - | 33% less |
| 5 | Density | 7.850 g/cm ³ | 1.400 g/cm ³ |
| 6 | Mass | 1729 lbs (784 kg) | 886 lbs (402 kg) |
| 7 | Duct thickness | 0.6 mm | 3 mm |
| 8 | Fan Motor Power Pitch angle | 2.1 kW 12° | 1.5 kW 8° |

VIII. LIFE

The average lifespan of PVC pipes is 50 to 70 years. While according to many of the plastic manufacturer it may last up to 100 years or more. The lifespan of the PVC pipes is also depending upon the environmental conditions and where it has been fitted [19].

Whereas galvanized steel pipes have an average life expectancy of 30 to 40 years. This is comparably lower than PVC pipes [4].

IX. CONCLUSION

From Table II difference in cost can be easily compared. With 45.47% saving in material, 6.6% saving in fan motor and 98.98% saving in other accessories. Average percentage saving while using PVC ducting over GI ducting accumulates to 50.35%, further long term saving can be achieved in terms of running cost and maintenance cost. From figure 16 one can easily depict the substantial increase energy consumption and its cost for GI ducting with respect to PVC ducting and long term gain can easily be achieved with PVC ducting.

X. FUTURE SCOPE

Few disadvantages of PVC material include material transportation is difficult, custom GI duct shapes are easily available in the field than PVC duct shapes which often must be specially ordered from a manufacturer, damaged parts can be easily replaced in GI ducting and PVC material is more prone to cracking and failure in term of strength as it is weaker. Fitting for PVC cost more but it can be overcome by custom manufacturing. Although having few disadvantages PVC ducting can be used in application specific places. With upcoming advancement in technology these disadvantages can be overcome with time.

REFERENCES

- [1] *Duct System Design Guide*, McGill AirFlow Corporation, USA, 2003, ch. 1,2,4, Appendix
- [2] *ISHRAE HVAC Data book*, ISHRAE, HVAC Engineers Data Book, Inch – pound version, 1st edition, 2017.
- [3] Takeshi IWASAKI, Jun OJIMA, *et al.*, “Friction loss in Straight Pipes of Unplasticized Polyvinyl Chloride”, National institute of Industrial Health, Kawasaki, Japan, 1996.
- [4] Viral P. Shah, David Dabella, Robert Ries, “Life Cycle assessment of residential heating and cooling systems in four regions in the in the United States”, Elsevier, 2007, *Energy and Buildings* 40 (2008) 503–513.
- [5] “An analysis of power tariffs across India”, PHD Research Bureau, PHD Chamber of Commerce and Industry, New Delhi, India. [Online]. Available: <https://www.phdcci.in/wp-content/uploads/2018/11/4.-An-analysis-of-power-tariffs-across-India-feb-2013.pdf>
- [6] *Indian Standards Air Ducts – Specification (Second Revision)*, IS 655:2006, Bureau of Indian Standards, New Delhi, India, BIS 2006, ICS 91.140.30, pp 6
- [7] *Air Filtration Products Catalog*, AAF International, USA, pp 78. [Online]. Available: https://www.turtle.com/ASSETS/DOCUMENTS/ITEMS/EN/AAF_3102040808_Catalog.pdf
- [8] *VOLUME CONTROL DAMPERS Catalog*, Air Master Equipments India Pvt. Ltd., India. [Online]. Available: http://www.airmasteremirates.com/downloads/Chapter_16-volume%20control%20damper.pdf
- [9] *Axial Flow Fans*, AMCA Oriented Ratings, Wolter Ventilation Co Ltd, Thailand, A09. V2012/June, pp 1-22. [Online]. Available: https://my.amca.org/members/documents/catalogs/16368_Approved%20Catalogs_A09-G%20V2012%20June%202012_2012_06_20.pdf
- [10] Engineering Toolbox, *Velocity classification of Ventilation Ducts*, Accessed 23rd April 2020 <https://www.engineeringtoolbox.com/velocities-ventilation-ducts-d_211.html>
- [11] Hunker, *Can I Use PVC Pipe for Air & Heating Ducts?*, Accessed 3rd May 2020, <<https://www.hunker.com/12581972/can-i-use-pvc-pipe-for-air-heating-ducts>>
- [12] Indiamart, *PVC Resin(Product search)*, Accessed 5th May 2020 <<https://dir.indiamart.com/impcat/pvc-resin.html>>
- [13] Anand Sales, Uttar Pradesh, *Iron plain sheet (Product search)*, Accessed 5th May 2020 <<https://www.anandsales.in/iron-plain-sheet.html>>
- [14] Indiamart, *Liquid PVC pipe adhesive*, Accessed 7th May 2020, <<https://www.indiamart.com/proddetail/pvc-pipe-adhesive-20290715591.html>>
- [15] Indiamart, *Nut and bolt*, Accessed 7th May 2020, <<https://www.indiamart.com/proddetail/ms-nut-and-bolt-12423834588.html>>
- [16] Indiamart, *HVAC insulaton*, Accessed 7th May 2020, <<https://www.indiamart.com/proddetail/hvac-duct-insulation-11697251530.html>>
- [17] Vashi Electricals™, *ABB Motor(1.5kW)*, Accessed 10th May 2020 <<https://vashielectricals.com/p/abb-motor-m2bax100la6-ie2-1-5kw-2-hp-6-pole-1000-rpm-flange-mounting-b5-frame-1001-415v-50hz-ip55/>>
- [18] Vashi Electricals™, *ABB Motor(2 – 3 kW)*, Accessed 10th May 2020 <<https://vashielectricals.com/p/abb-motor-m2bax100lb4-ie3-2-2kw-3-hp-4-pole-1500-rpm-foot-cum-flange-mounting-b35-frame-1001-415v-50hz-ip55/>>
- [19] Plastic Pipe org., *Standard Specifications, Standard Test Methods and Codes for PE Piping Systems*, ch.5, pp 125 – 147, Accessed 10th May 2020 <<https://plasticpipe.org/pdf/chapter05.pdf>>