

# Arduino based Smart Pill Box for Diabetic Patients

<sup>1</sup>Gopireddy Ganga Sathya Vani <sup>2</sup>T.Venkata Ramana

<sup>1</sup>PG Scholar, <sup>2</sup> Associate Professor

<sup>1,2</sup>Department of ECE, Siddartha Educational Academy Group of Institutions, Tirupati, Andhra Pradesh, India.

**Abstract:** The project's main aim is to make a Smart medicine box for those users who regularly take medicines and the prescription of their medicine is very long as it is hard to remember to patients and also for their care giver. Also Old age patients suffer from problems of forget to take pills on proper time which causes certain health issues for patients having Permanent diseases like diabetes, blood pressure, breathing problem, heart problems, cancer diseases etc. These problems in hospitals & people around us who have such kind of diseases and thus based on these two problems we made smart medicine box which solve these problems by Setting up time table of prescribed medicines through push buttons as given in prescription. Therefore at the time of taking medicine system generate Notification sound and display the Bright light in certain pill boxes. So, patient can know the specific number of box from which he has to take out medicines.. And also we have another future is that to find the heart rate of the patient.

**Index Terms** – Arduino UNO, Pill box, Buzzer,etc.

## I. INTRODUCTION

Currently, worldwide aging and regularity of persistent diseases are flatterer a broad concern. Numerous countries are undergoing hospital restructuring by reducing number of hospital beds and escalating home healthcare, which is envisioned to perk up health care quality, has fascinated wide-ranging attention. In order to track the physical status of the elderly and, in the meanwhile, to keep them healthy, the proposed idea will be helpful. IOT expands the Internet into our everyday lives by wirelessly connecting various smart objects, and will bring significant changes in the way we live and interact with smart devices. The new wave in the era of computing will be outside the sphere of the conventional desktop. Internet of Things (IOT) is a network where many of the objects that surround us will be networked in one form or another. By using this technology the health statistics of medication are observed. In this process of encryption the schedule data or doctor's prescription are send to pill box through mobile app. The LEDs are placed for indication and buzzer for alarm alerts and reset button is used to count for medicine in cloud platform. The existing techniques to the market for the reminder include a pill box. But this does not help in checking the medicine. This proposed idea is valuable solution to the medical noncompliance problem. The innovation scheme to help patient keep trail of their medicine consumption through a series LED alarm indicator signal and audio alarm indicator signals.

**The main objectives of the project are:**

- Dispense of medicines from pill box at scheduled time.
- Medical alerts to care taker and retailer.
- Online report generation of medicine.
- Real-time health statistics monitoring of medicines.
- Configuration data is send through IoT.
- Easy to find temperature and Heart Rate of the patient.

## II. INTERNET OF THINGS

The Internet of Things (IOT) is an important topic in technology industry, policy, and engineering circles and has become headline news in both the specialty press and the popular media. This technology is embodied in a wide spectrum of networked products, systems, and sensors, which take advantage of advancements in computing power, electronics miniaturization, and network interconnections to offer new capabilities not previously possible. An abundance of conferences, reports, and news articles discuss and debate the prospective impact of the "IOT revolution"— from new market opportunities and business models to concerns about security, privacy, and technical interoperability.

IOT systems like networked vehicles, intelligent traffic systems, and sensors embedded in roads and bridges move us closer to the idea of "smart cities", which help minimize congestion and energy consumption. IOT technology offers the possibility to transform agriculture, industry, and energy production and distribution by increasing the availability of information along the value chain of production using networked sensors. However, IOT raises many issues and challenges that need to be considered and addressed in order for potential benefits to be realized

## III. LITERATURE SURVEY

[1] *A Smart Pill Box with Remind and Consumption Confirmation Functions* Author: Huai-Kuei Wu, Member, Chi-Ming Wong, Pang-Hsing Liu, Sheng-Po Peng, Xun-Cong Wang.

Population aging could be a international issue that affects several developing countries like Taiwan. The natural decline in physical operate with aging results in a rise in incidences of assorted chronic diseases in older individuals, most patients with chronic diseases ought to take medications over a chronic amount of your time so as to stabilize their conditions. making certain that the patients consume the proper medication at the acceptable time becomes crucial. This paper proposes a wise pill box equipped with a camera

and supported the drugs bag conception. The matrix Universal Product Code written on the drugs luggage is employed to act with the pill box up order to perform pill prompt and ensure functions. The members of the family or patients ought to fill the drugs within the pill box manually, this can be an extra responsibility for members of the family of the older, or maybe the patients.

**[2] IoT Platform Based Intelligent Medicine box Author: Ninu P.J.1, Varun Kesav M.N.2 M.Tech Student, Department of ECE, Vidya Academy of Science and Technology, Thrissur.**

Most of the elders have multiple chronic diseases, and that they use medicines to stabilize their health conditions. Pharmacists Association suggested that the family ought to be a lot of involved on medication safety of the elders. Most patients with chronic diseases ought to take medications over a long amount of your time so as to stabilize their health conditions. Confirming that the patients consume the proper medication at the right time becomes crucial. associate IoTbased intelligent home-based health care platform, that absolutely connects sensible sensors connected to the bod for biological watching and intelligent medical packaging for daily medication management. The system will offer timely reminders to patients concerning their medication, and precisely management the kind and quantity of prescribed medicines, therefore avoiding medication misuse and abuse. once a patient consults a doctor, his/her details as well as drugs prescription are uploaded to the online server. From the remote physician's perspective, it's terribly convenient to form or update a prescription for a selected patient.

**[3] A Mobile Phone Based Medicine In-take Reminder and Monitor Author: Mei-Ying Wang, John K. Zao, P.H. Tsai, J.W.S. Liu**

Out-patient medication administration has been identified as the most error-prone procedure in modern healthcare. Under or over doses due to erratic in-takes, drug-drug or drug-food interactions caused by un-reconciled prescriptions and the absence of in-take enforcement and monitoring mechanisms have caused medication errors to become the common cases of all medical errors. Most medication administration errors were made when patients bought different prescribed and over-the-counter medicines from several drug stores and use them at home without little or no guidance. Elderly or chronically ill patients are particularly susceptible to these mistakes. A smart phone application designed to help patients avoiding these mistakes. It can remind its users to take the correct medicines on time and record the in-take schedules for later review by healthcare professionals. It is equipped with user friendly interfaces to help its users to recognize the proper medicines and obtain the correct instructions of taking these drugs. It can maintain the medicine in-take records on board, synchronize them with a database on a host machine or upload them onto a Personal Health Record (PHR) system.

**[4] ArduMed - smart medicine Reminder for old people Author: Mayuresh Waykole, Vatsalya Prakash, Himanshu Singh, Nalini N VIT University, Vellore**

It's a frequent observation that people provide a lot of preference to their work and alternative material things than

taking care of their health. If smart, working adults will forget taking correct medications, the situation will only be worse for our folks and grandparents. usually they forget to require their medications or take drug of it, leading to any health deterioration. Our system aims to reduce this downside by reminding patients regarding their medications and showing them the proper quantity of medication to require. it's a combination of physical and digital reminder that may be useful for individuals of any age, however is specially useful to previous people that forget taking their medications.

**[5] Medication reminder and healthcare – an android application Deepti Ameta, Kalpana Mudaliar and Palak Patel Gandhinagar Institute of Technology, Gandhinagar, Gujarat, India**

This is an Android-based application during which an automatic alarm ringing system is enforced. It focuses on doctor and patient interaction. Patients need not keep in mind their medication dose timings as they'll set an alarm on their dose timings. The alarm are often set for multiple medicines and timings together with date, time and medication description. A notification are sent to them through email or message within the system ideally chosen by the patients. they'll search doctor malady wise. The patients can get the contact details of doctors as per their convenience. additionally the users will see totally different articles associated with medical fields and health care tips. The system focuses on straightforward navigation and smart interface. several such Medical Reminder Systems are developed wherever a new hardware is needed however in our work we have created an effort to develop a system that is economical, time-saving and supports medication adherence

#### IV. PROPOSED SYSTEM

To ensure the people consume medicines as per schedule time table, here we developed a smart pill box. The schedule data/configuration data is send to the pill box through IoT. The smart pill box contains Arduino MCU, LED display, LEDs, buzzer, buttons ,Pulse Sensor and Temperature Sensor.

The LED are used to display the commands in pill box by MCU. The Wi-Fi module is configured with IoT. The configuration data is send to the smart pillbox when the configuration is in ON mode. The concerned LED glow with buzzer at schedule time

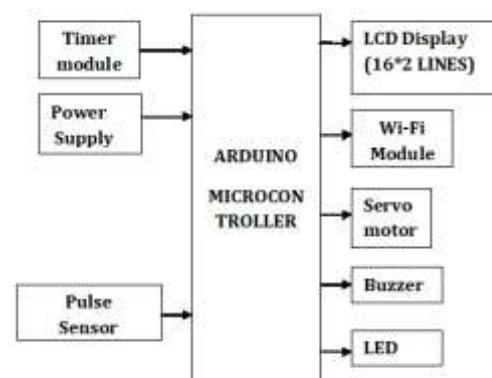

Fig.1 Proposed Block diagram

## A. Explanation of Block Diagram

### Arduino UNO:

We are using Arduino UNO because it use 8 bit microcontroller ATmega328P and it has 32KB flash memory. These features are beneficial in our project and that's why we used Arduino UNO. Arduino UNO board is connected with all other modules also it controls all other modules & made the interfacing easier. It also has internal EEPROM which stores real time data in it. Our project is based on embedded system we are using Arduino Uno for interfacing all things In that Arduino is an open-source which is easy-to-use hardware and connected software. So Arduino is path between hardware and software. Arduino boards read inputs from a press a button- and turn it into an output, turning on an LED and buzzer, you can tell your board what to do by sending a set of instructions to the microcontroller of Arduino. To do so you use the Arduino programming language , and the Arduino Software (IDE), based on Processing. The programming platform is Arduino IDE and programming language is standard C. we made program for all different module that we are using in our project. Like RTC module, LCD module 16\*2 so firstly we have to add library in Arduino IDE software and after that we made programming.

### LCD:

We used 16\*2 LCD module in our project which is connected to Arduino UNO through a LCD interface IC or directly to its address and data bus and few control pins. LCD shows the current time and date which RTC sends the data to LCD module.

### RTC module:

We used Tiny RTC I2C module which uses I2C protocol and it is useful in our project. RTC module has internal CMOS cell so it does not needs external power supply to update time and date.

### Buzzer:

Buzzer will ring at proper time when pills have to be taken.

### LED:

We have 7 boxes having an LED in each box which blinks to show us the specific box from which the pills needs to be taken at given time.

### Pushbuttons:

We used 3 push buttons from which first one is used for setting medicine, second one is used for increment and third one is used for next. First button takes us to the menu of setting medicine, second button is used to increment the number of hour and minute which we needs to set and third button takes us forward from hour to minute and from minute to the next time.

### Pulse Sensor:

This sensor is used to find the heart rate of the patient continuously.

### Temperature Sensor

This sensor is used to detect the temperature of the patient.

### Servo Motor:

Servo Motor is used to make easy to open and close the box to take pills.

## B. ADVANTAGE

### Cost efficient:

Our product cost is affordable compare to other product available in market.

### User friendly:

User can set time table of medicine by himself.

### Highly reliable:

Good in quality and performance; able to be trusted for patients & old age people.

### Provide comfort and health:

Comfortable for old age people and provide healthy life for patients who are regularly take medicines.

### Long-Lasting:

The product can be used for long time.

### Easy to use and manufacture:

It is very easy to use and manufacture.

### Accurate result:

Alarm will ring at proper time which is set by user previously.

### Easy to maintain:

It need less Maintenance. It is one time investment afterwards it can be used continuously.

## V. EXPERIMENTAL RESULTS

We made our project as useful for the patient who needs this and all related users. We conclude result that our project is useful for those people who are taking pills regularly, prescription of medicine is very long and hard to remember for those users. Our product is so useful that it can cure those patients illness and there will no need of taking care of these types of patients so caregiver has no tension about their health and they will live healthy and tension free life.



Fig.2 practical prototype model



Fig.3 LCD Showing the Pulse sensor operation

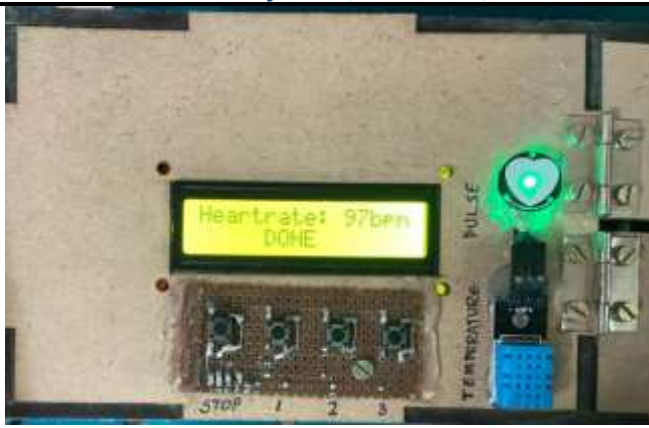

**Fig.4 LCD Showing the Heart rate when put finger on Pulse sensor**

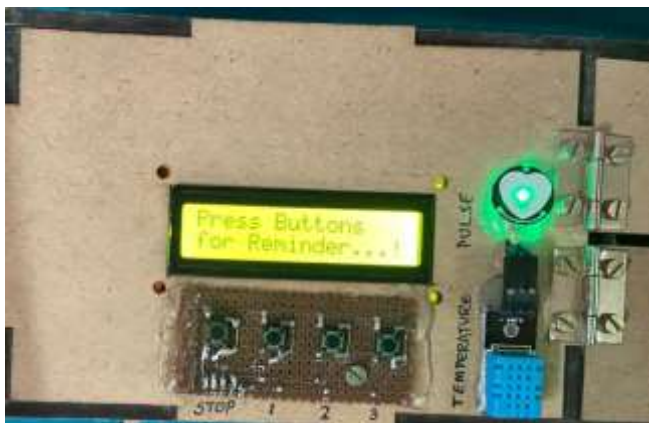

**Fig.5 LCD Showing the setting remainder for pills**

## VI. CONCLUSION

The goal of our project is to provide healthy and tension free life to those users who are taking regularly pills and to provide this product at affordable cost also. Our project is also reusable by exchanging those other medicine box that has only alerting system and are non-usable or unaffordable compare to our product.

### Future Work

While this paper has demonstrated the potential of the assistive technology, from an specific and effective pillbox device, many opportunities for extending the study of this paper is remain.

### • Infrared System

As pointed on section 5, there will be an additional study of the actual modules; one of them is the IR system. The IR 333-A transmitter and PD 333-3B\HO\L2 receptor are used but they have a lot of problems on its operating distance and receiver angle. Therefore the study more precise IR system is needed.

### • Touch Screen CTE 50

Another module marked as inconclusive is the TFT LCD Touch Screen. In this process the touch function is not available, but the goal is to use this interface to configure the medication scheme.

### Design

This prototype is "a proof of concept". Based on studies and the interviews the final design will be made. The

goal is to create a device with 28 compartments, 4 doses every day during 7 days. A 3D printer will be used.

### • Security

After the design is selected, a lock system will be added. The device will be used only by; doctors, keepers, and patients without significant disorders. They would only program the device with a personal password.

## REFERENCES

- [1] N. Sriskanthan and Tan Karand. "Bluetooth Based [1] Viral Shah, Jigar Shah, Nilesh Singhal, Harsh Shah & Prof. Prashant Uapdhayay, "Smart Medicine Box", Imperial Journal of Interdisciplinary Research (IJIR), Vol-2, Issue-5, 2016.
- [2] Naga Udayini Nyapathi1, Bhargavi Pendlimarri2, Karishma Sk3 , Kavya Ch4," Smart Medicine Box using ARM 7 Micro controller", International Research Journal of Engineering and Technology(IRJET) , Volume: 03 Issue: 05 | May-2016.
- [3] Aakash Sunil Salgia\*, K. Ganesan and Ashwin Raghunath, "Smart Pill Box", Indian Journal of Science and Technology, Vol 8(S2), 189–194, January 2015.
- [4] P. Raga Lavimal, Mr. G. Subhramanya Sarma2, "AN IOT BASED INTELLIGENT MEDICINE BOX", IJCSMC, Vol. 4, Issue. 10, October 2015, pg.186 – 191.
- [5] Suneetha Uppala1, B. Rama Murthy2, Smart Medicine Time Indication Box, International Journal of Science and Research (IJSR), Volume 6 Issue 1, January 2017.
- [6] Aakash Sunil Salgia\*, K. Ganesan and Ashwin Raghunath(January 2015), Smart Pill Box, US2009/0299522 A1.
- [7] Bo pi, Halton pi (May 5, 2016), Smart pill container, control method and system, US 20160120758 A1.
- [8] Joram Savir, Gilad Ben-Zur (3 Dec 2009), Online smart pill box dispensing system, US 20090299522 A1
- [9] Avinash Uttamrao Kulkarni(25 Jan 2011), Intelligent pill box, US 7877268 B2
- [10] Arjun Varman Balasingam,(4 Aug 2011), Smart medicine cabinet, US 20110187549 A1
- [11] <http://www.engineersgarage.com/contribution/medicine-reminder-using-arduino?destination=node/894202>
- [12] <https://learn.adafruit.com/ds1307-real-time-clock-breakout-board-kit/understanding-the-code>
- [13] <https://www.arduino.cc/en/tutorial/blink>
- [14] <http://www.instructables.com/id/I2C-LCD-Controller-the-easy-way/>