

# Design and Simulation of Single Phase Solar Inverter for a Residential Load

<sup>1</sup>M. Tanveer Maharaj, <sup>2</sup>Dr. Akshay A. Pandya

<sup>1</sup>Student, <sup>2</sup>Associate Professor

Department of Electrical Engineering

Birla Vishvakarma Mahavidyalaya, New v.v. nagar to Vallabh Vidyanagar- India

**Abstract :** In recent time we know that solar energy are more easier and enviro-friendly energy for convert in electrical energy. A various non conventional source like coal, gas, fuel are limited, so in future it is not available for energy conversation. Solar generation is generated DC energy and for that AC load needs to convert DC to AC so that it requires solar inverter. There are many solar-inverter available i.e. Diode clamped multi-level inverter, Cascade H-bridge multi-level inverter, Flying capacitor multi-level inverter. The proposed work is to design and simulation of Diode clamped multi-level inverter and Cascaded H-bridge multi-level inverter.

**Keywords:** - Solar energy, Renewable energy, DC-AC converter, PV array, Solar inverter, Multi-level inverter.

## I. INTRODUCTION

Electrical energy neither generated only it can be converted from other energy to electrical energy. Now days we know that electrical energy converted from many sources such as a renewable and non-renewable. A various non renewable source like coal, gas, fuel are limited, so in future it is not available for energy conversation. There are many solar-inverter available. In this work, the concept of a 5-level diode-clamp and modulate principle are implemented to control the output waveform approaching to the sine-wave as close as possible.

In this proposed work, solar PV array are used as a input dc voltage for a DC to AC converter. And that DC voltage converted in a AC voltage with efficient inverter and reduce a harmonics and improve in electrical power quality. For that purpose I simulate simple single phase full bridge inverter with pulse with modulation control for convert a solar panel output into AC output. After result for the same I need to improved waveform so that I simulate a multilevel inverter (5 level) for convert a PV module DC output to a AC output. This result waveform I found that is more improved and better power quality and nearly to sinusoidal waveform as compared to a single phase full wave inverter.

Today, it is hard to connect a single power semiconductor switch directly to medium voltage grids. For these reasons, a new family of multilevel inverters has emerged as the solution for working with higher voltage levels. The inverters with voltage level 3 or more are referred as multi level inverters.

Multilevel inverters have become attractive recently particularly because of the increased power ratings, improved harmonic performance and reduced EMI emission that can be achieved with the multiple DC levels that are available for synthesis of the output voltage. New diode clamping multilevel inverter.

Developed DC link capacitor voltage balancing in a three phase diode clamped inverter controlled by a direct space vector of line to line voltages. Simulations are performed using MATLAB-SIMULINK.

### Multi-level Inverter:

In basic structure of the multilevel inverter is to a sinusoidal voltage from different levels of voltages obtained from capacitor sources. It is being considered for an increasing number of applications due to high power capability and lower harmonics and lower commutation losses. Multilevel inverters have solution for high power and low harmonics of AC load.

Multilevel inverter are classified into following types inverter

- Diode clamped multilevel inverters
- Flying capacitor multilevel inverters
- Cascaded multilevel inverters

A diode clamped multilevel inverter needs  $m-1$  capacitor,  $2*(m-1)$  switching devices, and  $(m-2)*(m-2)$  clamping diodes are needed.

- For output  $V_{an} = 0$  turn on all lower switch  $S1'$  to  $S4'$ .
- For output  $V_{an} = V_{dc}/4$  turn on switch  $S4$  and  $S1'$  to  $S3'$ .
- For output  $V_{an} = V_{dc}/2$  turn on switch  $S3, S4, S1', S2'$ .
- For output  $V_{an} = 3V_{dc}/4$  turn on switch  $S2, S3, S4, S1'$ .
- For output  $V_{an} = V_{dc}$  turn on all upper switch  $S1$  to  $S4$ .

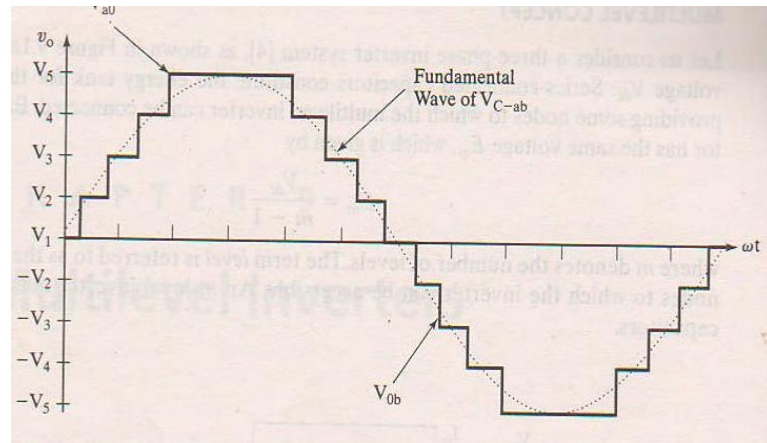

Fig. Output voltage waveform of 5 level multi inverter

## II. SIMULATIONS and RESULTS

### MATLAB Simulation of single phase inverter with PWM control-

A below circuit shows a MATLAB simulation model circuit of single phase full wave solar inverter with Pulse width modulation control. At input side of inverter low rating PV array is generated a DC voltage and its converted into an Sinusoidal AC voltage.

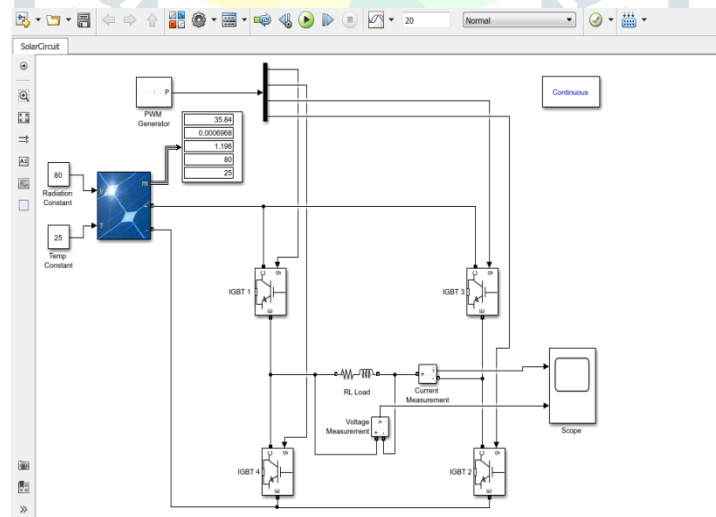

Fig. MATLAB simulation of single phase solar inverter

Following waveform are show a current and voltage waveform of a solar inverter respectively. From output side result we can say that it is nearly to the sinusoidal waveform.

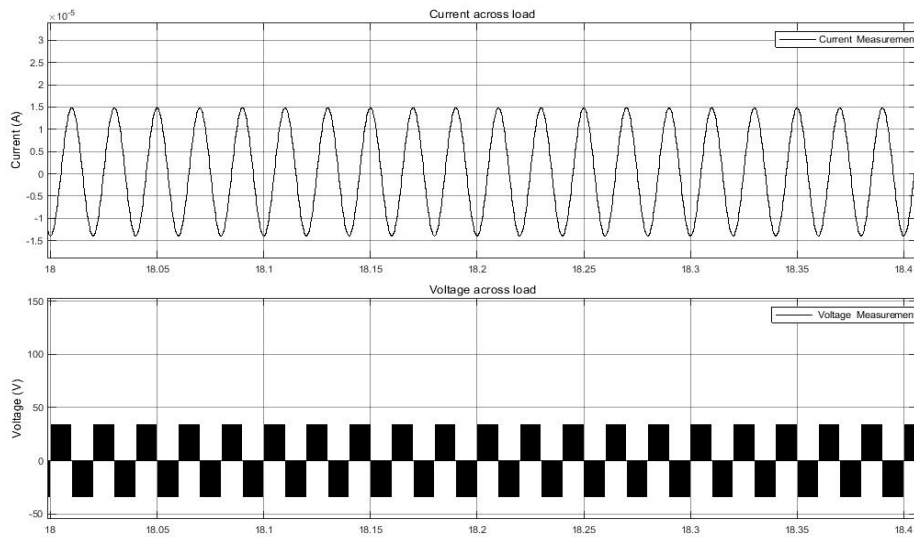

Fig. Output Current & Voltage Waveform respectively

**MATLAB Simulation of Solar multi-level inverter.**

Following figure shows a MATLAB simulation circuit of a Solar multi-level inverter with (5 level). At input side PV array connect and output of its DC voltage is given to a multilevel inverter which converts a stepped voltage waveform more nearly to sinusoidal waveform.

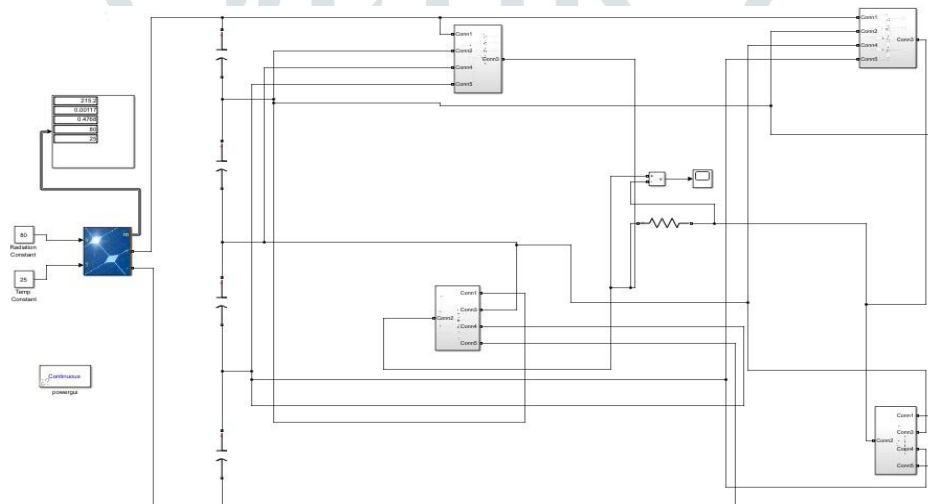

Fig. MATLAB Simulation circuit of multi-level inverter

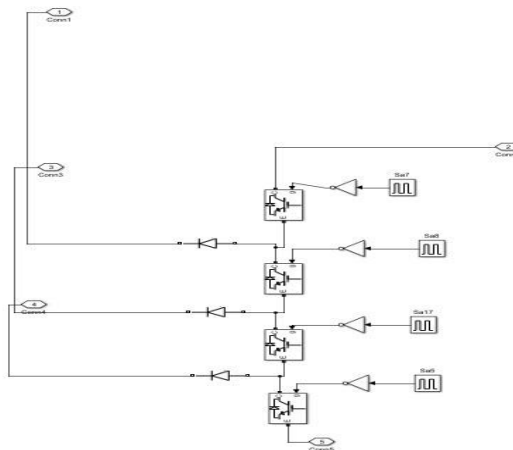

Fig. Subsystem in Multilevel inverter

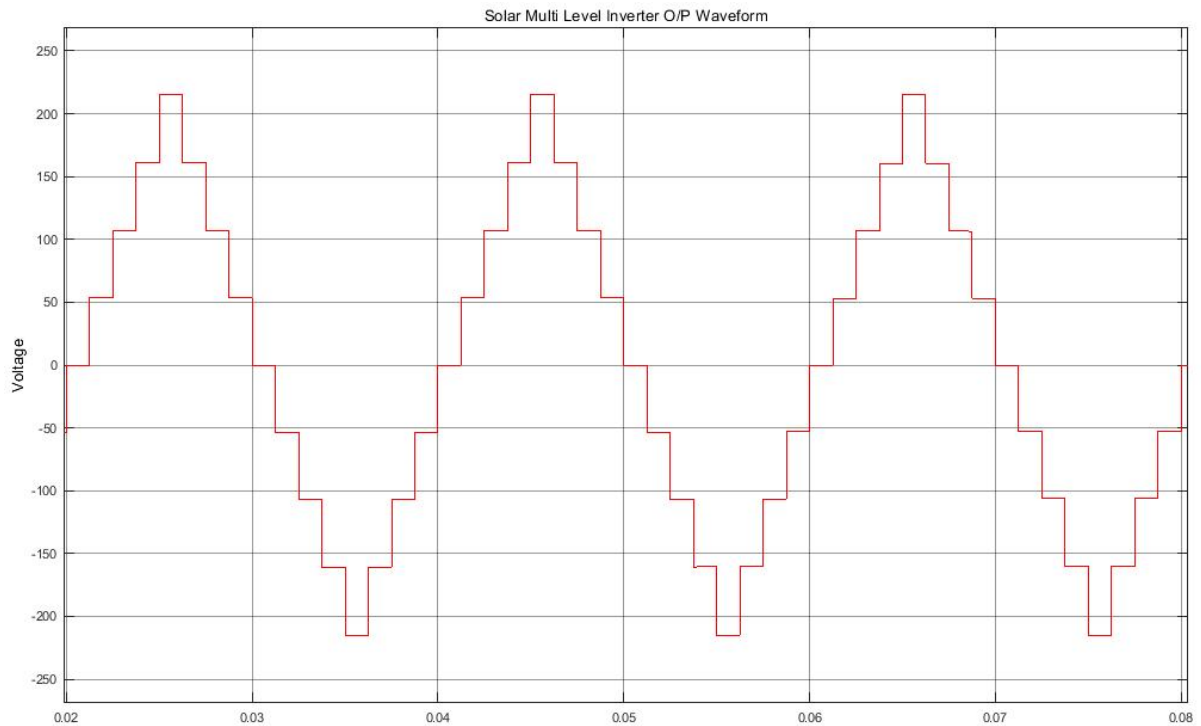

Fig. Output Voltage Waveform of Diode Clamped Multilevel Inverter

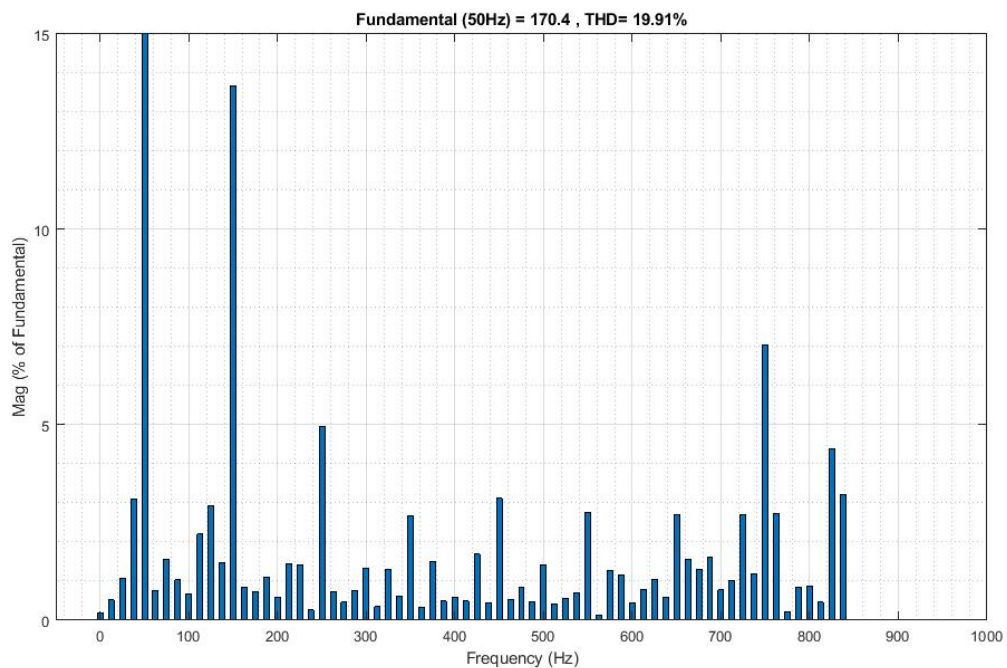

Fig. THD analysis of Diode Clamped MLI

#### MATLAB Simulation of Cascaded H- Inverter:

Following figure shows a MATLAB simulation circuit of H bridge multi-level inverter with (3 level). At input side different DC voltage source are connect in bridge type and output of its DC voltage is given to a multilevel inverter which converts a stepped voltage waveform more nearly to sinusoidal waveform.

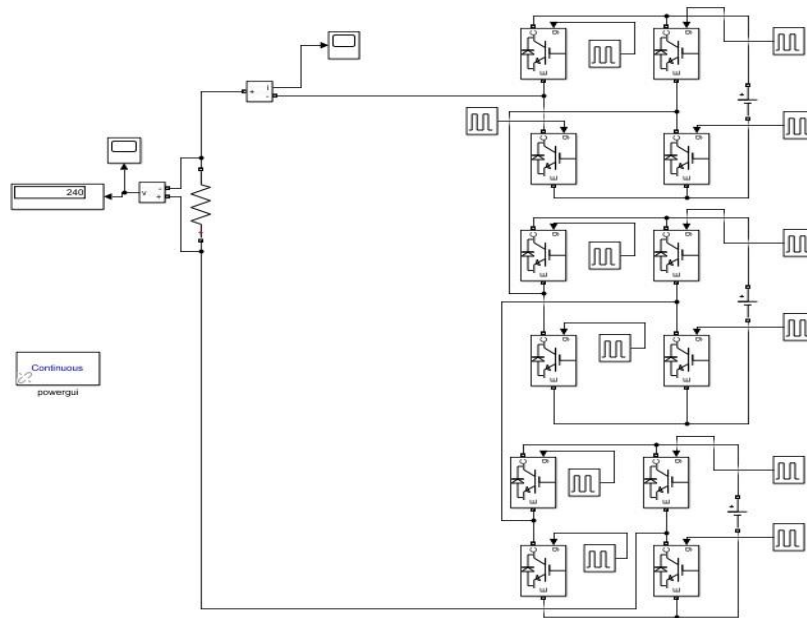

Fig. MATLAB simulation circuit of H-bridge MLI

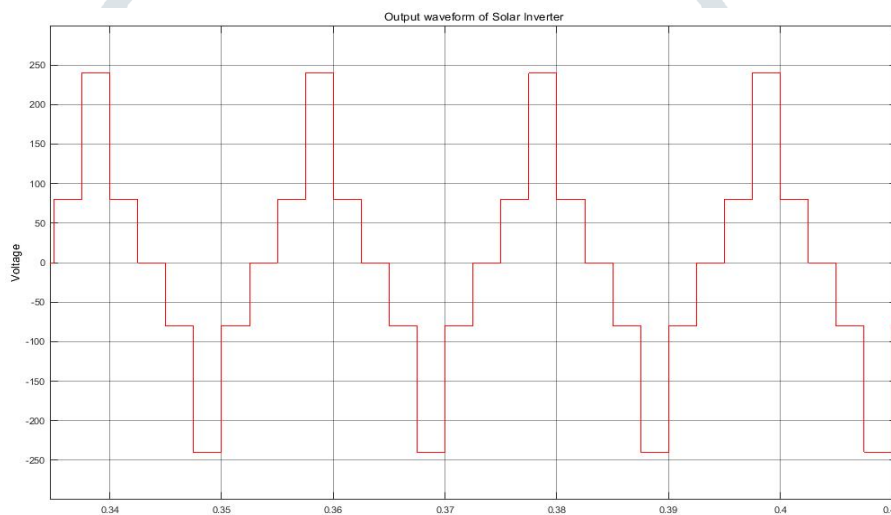

Fig. Output Voltage Waveform of Cascaded H-bridge MLI

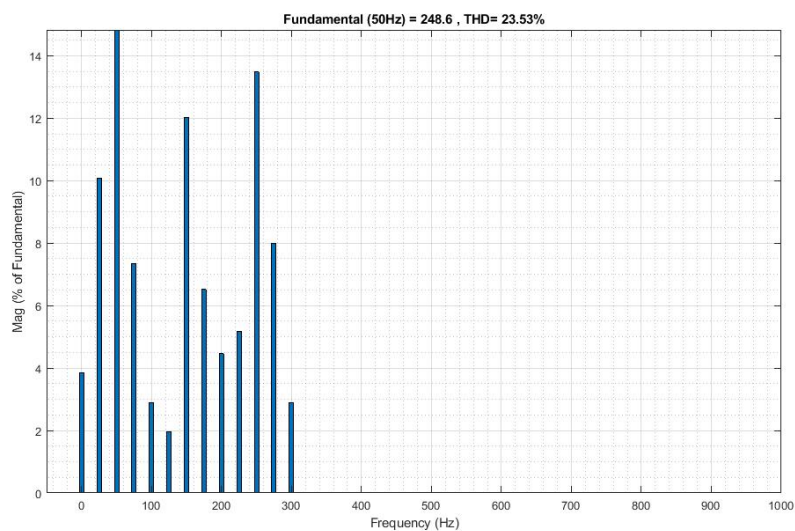

Fig. THD analysis of Cascaded H bridge MLI

Note that if number of voltage level increases it means that harmonics will reduce and better power quality.

### III. CONCLUSION

From above all discussion of different multilevel inverter i.e. single phase full wave solar inverter, single phase full wave solar inverter with PWM control, diode clamped multi-level inverter, cascaded H-bridge multi-level inverter. As per all waveform we can say that multi-level solar inverter had lower harmonics and much better waveform than single phase PWM solar inverter.

### IV. REFERENCES

- I. Smita Joshi, Neha Upadhyaya, "Design of small scale solar powered house", Birla Vishvakarma Mahavidyalaya, National Conference Paper, January 2016.
- II. Nilesh Patel, Deepali Sananse, Priyanka Bore, Quazi Jawwad Khan, Hemant T Ingale, S. K. Chaudhari, "Literature Review on Solar Wiring System", International Journal of Innovative Research in Science, Engineering and Technology (IJIRSET), Vol. 6, Issue 5, ISSN(Online): 2319-8753 May 2017.
- III. Aye Aye Mu, Dr. Aung Ze Ya, "Design and Analysis of Solar Power System for Sinywa Village in Mandalay Region", Yangon Technological University, Inter-national Conference Paper, June 2011.
- IV. Nithin Krishnan, Divya H., "Solar Smart Inverter: A Novel Design using Multi level Topology and Pulse Width Modulation with Load Detection", International Journal of Engineering Research & Technology (IJERT), Vol. 4 Issue 06, June-2015.
- V. Varsha Sahu, Shraddha Kaushik, "A New Five-Level Diode Clamp Multilevel Inverter Topology", International journal of creative research thoughts (IJCRT), Vol. 1 Issue 04, ISSN:- 2320-2882, April -2013.

