



## Design and optimization of 4-wheeler car front end for pedestrian safety

<sup>1</sup> Pravin Vijay Lohot, <sup>2</sup> Dattatray. S. Galhe, <sup>3</sup> Rajkumar. L. Mankar, <sup>4</sup> Khandu. M. Said, <sup>5</sup> Paresh S. Pawar

Department of Mechanical Engineering  
Jaihind College of Engineering Kuran,  
Savitribai Phule University  
Pune, India

**Abstract:** In engineering and technology safety of human life has always been a top priority. With the increasing usage of vehicles in everyday life, probability of deaths and injuries has also increased, but safety is important too. Choosing a safer car is very important to help prevent crashes and accidents. Thus, a crash-testing program is critical for the car makers and has contributed significantly to the improving safety of cars. According to the NCAP (New Car Assessment Program) of NHTSA (National Highway Traffic Safety Administration) cars made for model year 1997 and after must pass both the tests frontal crash testing, side impact crash testing and now they are focusing on pedestrian crash testing. The automobile industry were trying to decrease the death risk and injury level so pedestrian dummies are used to experiment and evaluate the impact safety of a certain car. However, such experiments are expensive and time consuming in addition to the limited number of pedestrian crash dummies. In this case study we are going to make FEA simulation model of physical setup so we can avoid high costly physical test to save high prototype cost and save time too. We are going to model FEA simulation with the help of (ECE R127) regulation using Hyper-mesh where the FE-dummy in a standing position was hit by a car model provided. However, with exception of a Head form impact test, Leg form test are performed for pedestrian injuries, and simple impact test and full body validation in a car-to-pedestrian collision (CPC) were performed in LS-DYNA and LS-PREPOST Software.

**Index Terms - pedestrian safety, design of 4-wheeler car front end**

### I. INTRODUCTION

Pedestrian injuries are a major global health problem. Each year 270 000 pedestrians are killed in traffic in the world, including 10 000 – 20 000 pedestrians who sustain disabling injuries every day. Therefore, there is a need to make crossing the roads safer. The risk of pedestrian accidents depends on traffic environment (i.e., road quality, traffic signs, respecting the laws...). Despite that the traffic environment has been developed in some countries; pedestrians are still subjected to severe injuries and fatalities.



Figure 1 Pedestrian Crossing the Road.



Figure 2 Pedestrian Walking between the Road.

In a car to pedestrian accident, there are many parameters involved that are decisive of the outcome of the incident, with a varying degree of responsibility; amongst them are the car developers. The vehicle industry is concerned with the passive safety, meaning that they should make efforts for developing protective systems in vehicles in order to prevent or at least minimize the pedestrian injuries.

During the development phase of the passive safety systems, crash test dummies are used in experiments. Full scale experiments with the crash dummies are necessary to test and evaluate a certain developed safety system. The impact dummies have existed since the seventies. They have the advantage of being robust, reproducible, and giving valuable data regarding the forces acting on the body experienced in a car crash.

However, the number of standing physical dummies that can be used for pedestrian impacts are limited. Meanwhile there is a great need for a pedestrian model that can be used in the development and evaluation of pedestrian injury countermeasures. Therefore, Autoliv have developed their own physical pedestrian dummy mainly using components from different available

dummies on the market (i.e., Dummies used for frontal and side impact collision tests). Only a very limited number of components were developed and manufactured in house.



Figure 3 Dummy Impact On Front End.



Figure 4 Pedestrian Crossing the Road

Yet, full scale dummy tests have a high cost and are time consuming. The car automotive industry has therefore started to use virtual models in simulation to a larger extent in their work since they make it possible to optimize the test before doing the experimental test to a much lower cost.

There is however still no available mathematical model of this pedestrian dummy developed by Autoliv. The aim of this thesis was therefore to develop a finite element model to represent the physical dummy in the simulation. Modelling with finite element method is specifically chosen for its many computational advantages, and in addition it's adaptable to any complex geometry.

This report presents different steps in modelling the pedestrian dummy using the finite element method.

## II. LITERATURE SURVEY

[1] "G. S. e. al, "An Enhanced Methodology for light weighting a vehicle design consideration front crashworthiness and pedestrian impact safety requirements", 11th International Symposium on Plasticity and Impact Mechanics, 2017

The current study research that lights weighting of an automotive structure can be done by accounting for pedestrian and major front occupant safety targets, simultaneously leading to an optimal mass solution with 40% weight reduction of the component consider, to minimizing the total mass of key front body structure components like front rails and bumper to ensure vehicle crashworthiness and pedestrian impact safety.[1]

[2] K. T. e. al, " Accident Characteristics In Car To Pedestrian Impacts",GDV Institute of Vehicle Safety, Munich

This study was to show typical accident characteristic of car to pedestrian accident. It shows the graphical representation of pedestrian accident with age distribution of pedestrian killed initial area of impact and kinematics group for children up to 10 years of age. Data origin were insurance record of the GDV (German Insurance Association – Institute of vehicle safety), where 1200 car to pedestrian accidents were investigated by engineers and physicians. [2]

[3]. D. R. e. al, " Pedestrian And Their Survivability At Different Impact Speeds",Loughborough University, United Kingdom

The research objective of this paper is to outline the pre and post crash circumstances of 108 pedestrian crashes including travelling speeds, time and distance from the moment, the impact was inevitable are described, it has been observed that a reduction of the speed limits on a road from 60 kmph to 50 kmph produced a 20% drop in pedestrian accident and 50% drop in pedestrian fatalities. [3]

[4] C. Catherine Masson et al, "Pedestrian Vehicle Accident Analysis Of 4 Full Scale Tests With PMHS" , French National Institute for Transport and Safety Research, France

In this paper of pedestrian leg impact requirement, the acceleration measured at the upper end of the tibia shall not exceed 200g to avoid contact bone fracture, the result suggest that impact location of lower leg depend directly on the posture and the height of the pedestrian. Here four full scale tests were performed with PMHS ( Post Mortem Human Subject), the result have showed a higher tibia initial acceleration in two test and for both test the vehicle used was a big car and the impact speed around 39km/h, this test suggest the shape and model of the car has an effect on the tibia acceleration more significant than car velocity. [4]

[5] E. R. e. al, "literature review of pedestrian fatality risk as a function of car impact", Accident Analysis and Prevention, 2011

The aim of this review was to this review was to evaluate all studies of pedestrian fatality risk as a function of car impact speed, they have analysis the different paper from British data, Swiss data, US data, German data, Korean data, Chinese data and suggest that most studies of pedestrian fatality risk as a function of car impact speed were based on European data and accessing impact speeds in car to pedestrian crashes is difficult and requires presence at the accident scene in order to collect relevant evidence and information. [5]

[6] M. M. Ptak et al, " the influence of frontal protection system design on pedestrian passive safety, Archives of Civil And Mechanical Engineering, 2011

The aim objective of this research is to determine a minimum impact on lower limbs, pelvis and head injuries caused by pedestrian head on collision with vehicles, to modify the bumpers, wiper arms, headlight design, hinges has been modified. One way to increase pedestrian safety is the use of car high deformable bumpers, through the use of additional energy absorbing components mounted on the front part of the vehicle. One way to increase pedestrian safety is the use of car high deformable bumpers for absorption of impact energy. [6]

[7] D. G. T. e. al, "Computational And Experimental Analysis Of Head Injury Criteria (HIC) In Frontal Collision Of Car With Pedestrian", SAE International, January 2019

The aim of this study is to analysis the effect of car bonnet thickness, number of arrangement of under bonnet stiffeners on head injury level with the help of (HIC) Head Injury Criteria, hence optimal bonnet thickness, least number and geometry of stiffeners and enough structural strength is important for bonnet to reduce injury level, thick bonnet and stiffness reduce deformation of the bonnet during collision and increase injury level of pedestrian, result is plot in the form of stress, strain and HIC, the age class of these victims is 20-29 years age group, out of them 80% are male however number of women victims is increasing over past few year. [7]

[8] D. B. e. al, "Performance Assessment Of Pyramidal Lattice Core Sandwich Engine Hood For Pedestrian Safety", SAE International, October 2019

This paper study about the hood structure not only protect the engine cavity but also keep pedestrian away from the parts of that cavity, GFRP pyramidal lattice core structures are used in automobile, which is good energy absorption, it absorbs impact energy rather than transmitting in to the hood, this will minimize the severity rate of injury of pedestrian during accident, there are different types of lattice core structure they are ISOGRID, ANISOGRID and Pyramidal lattice core. And Aluminum Reinforced Polycarbonate material provides enough energy absorption capabilities to protect pedestrian. [8]

[9] J. S. G. e. al, "Injury Reduction in Vehicle to pedestrian collision" SAE International, November 2019

This study indicates that how this system is effective in reducing the fatalities in pedestrian accident and how to evaluate the performance of these deployable pedestrian protection system (DPP), help to reduce the pedestrian head injuries significantly. And the result indicates that it is worthwhile to use the DPP system for controlling and reducing the road fatalities. [9]

[10] I. K. e. al, "Optimal Design Of Light Commercial Vehicle Headlamp For Pedestrian", International Conference On Computational And Experimental Science And Engineering (ICCESEN), 2016

This paper study a new headlamp housing design was performed in the term of pedestrian protection and the existing model of head lamp was examined in three different analysis static, modal, Non-linear explicit analysis were conducted for each condition in Abaqus Software and result conclude that new head lamp housing model was created by weakening in critical zones of the existing model, to reduce stress around headlamp housing connection region in a crash. [10]

[11] Y. M. e. al, "A 6 Year Old Pedestrian Finite Element Model For Simulating Pedestrian Impacts", 14th International Ls-Dyna Users Conference. 2016

This paper study an advanced and computationally efficient finite element (FE) model corresponding to a 6 year old pedestrian child was developed in LS-DYNA, by Global Human Body Model Consortium (GHBMS) family of models, based on geometry reported in literature and material properties were applied, based upon published studies and result conclude that the child pedestrian model predicted the most common injuries observed in pedestrian accidents but more confidence could be added to the model for improvement and validation [11]

### III. PROBLEM STATEMENT

The main aim of this project is to reduce the effect of car frontal impact on pedestrian body.

### IV. OBJECTIVES

- To carry out in-depth research of literature review for safety of pedestrian with Auto vehicles
- To analysis the effect of vehicle frontal impact on pedestrian body
- To reduce the injuries, occur in pedestrian leg form
- To reduce the injuries, occur in pedestrian head form
- To increase the safety of the pedestrian on vehicle front end
- To modify the different part of vehicle to absorb more kinetic energy in Hyper mesh
- To analysis the vehicle with different dummy by running the models in Ls-Dyna

### V. METHODOLOGY

- Find out literature survey, gathered research papers
- Regulation and document reading
- Meshing the different car models
- Pre-processing in Hyper mesh software
- Solve in LS-DYNA software
- Post-processing in LS PRE-POST & Hyper view software

### VI. CAE:

Computer Aided Engineering is a broad usage of computer software to aid in engineering analysis tasks. It includes Finite Element Analysis (FEA), Computational Fluid Dynamics (CFD), Multibody dynamics (MBD), Optimization, etc. It is used in almost every industry such as aerospace, automobile manufacturing.

### FINITE ELEMENT ANALYSIS:

Finite element analysis means we must convert total continuous model into discretized model because to solve problem in such manner is just not possible. Numerical method like FEM is based on discretization of integral form of equation. Basic theme of all numerical methods is to make calculations at only limited number of points & then interpolate the results for entire domain (surface or volume). Even before getting the solution, we assume how the unknown is going to vary over a domain. Say for

example if for structural analysis meshing is carried out by linear quadrilateral element then assumption made is linear variation of displacement over the domain, for 8 noded quadrilateral elements, assumption is parabolic variation. This may or may not be the case in real life & hence all numerical methods are based on an initial hypothetical assumption. After getting the results there are different ways to check numerical as well as practical or field result Correlation accuracy & minimization of the error.

All real-life objects are continuous. Means there is no physical gap between any two consecutive particles, i.e. as per material science, any object is made up of small particles, particles of molecules, Molecules of atoms as so on and they are bonded together by force of attraction. Solving a real-life problem with continuous material approach is difficult and basic of all numerical methods is to simplify the problem by discretizing it. In simple words nodes work like atoms and there is gap in between filled by an entity called as element. Calculations are made at nodes and results are interpolated for elements

Interpolation function is that function which interpolate result throughout the element because all finite element methods are worked on basis that calculation are carried out at node point and if want answers in between the two nodes we have to use interpolation function to get the result. Interpolation function is varied according to the different element shape.

#### **ADVANTAGES OF FEA PROCESS:**

- Visualization
- Design cycle time
- No of prototype
- Testing
- Optimum design

#### **HYPERMESH:**

Altair HyperMesh is a high-performance finite element pre- and post-processor that is compatible with most widely used finite element solvers. Hyper Mesh's user-interface is easy to learn and supports many CAD geometry and finite element model files, thus increasing interoperability and efficiency. Advanced functionality allows users to efficiently mesh highly complicated models. It also allows user-defined quality criteria and controls, morphing technology to update existing meshes to new design proposals, and automatic mid-surface generation for complex designs with varying wall thicknesses. Automated tetra-meshing and hexa-meshing minimizes meshing time, while batch meshing enables large-scale meshing of parts with no model clean-up and minimal user input.

HyperMesh incorporates a variety of tools for seamless integration into any existing engineering process. It allows customizing the layout of Hyper Mesh's menu system through an easy-to-use interface according to the user's convenience. Users can take advantage of the power within the Tcl/Tk toolkit to build custom applications fully integrated with HyperMesh. One can create macros that automate a process or series of steps. Export templates and input translators increase the flexibility making Hypermesh compatible with many solvers. The export templates allow the HyperMesh database to be written out to formats to non-supported solvers. The input Translators support by adding the user's own input translators for reading different analysis data Decks.

HyperMesh provides direct access to a variety of industry-leading CAD data formats for generating finite element models. It also provides robust tools to clean imported geometry containing surfaces with gaps, overlaps, and misalignments, which prevent auto meshing and high-quality mesh generation.

By eliminating misalignments and holes, and suppressing the Boundaries between adjacent surfaces, users can mesh across larger, more logical regions of the model while improving overall meshing speed and quality. Boundary conditions can be applied to these surfaces for future mapping to underlying element data. HyperMesh includes a sophisticated suite of easy-to-use tools to build and edit models. For 2D and 3D model creation, users have access to a variety of mesh generation panels besides

HyperMesh's powerful auto-meshing module. Automatic mid-surface generation, a comprehensive laminate modeler and morphing (to stretch existing FE meshes to new design Geometries) and creating surfaces from the existing mesh offer new levels of model manipulation.

The surface auto-meshing module in HyperMesh is a robust tool for mesh generation that provides users the ability to interactively adjust a variety of mesh parameters for each surface or surface edge. These parameters include element density, element biasing, mesh algorithm, and more. This gives very high user control over the meshing process enabling meshing of even highly complicated surfaces with desired quality.

HyperMesh supports a host of different solver formats for both import and export. Along with fully supported solvers, HyperMesh also provides the flexibility to support additional solvers via a complete export template language and C libraries for development of input translators. Some of these are stated below.

Different Types of Solvers

OPTISTRUCT	LS-DYNA	ANSYS
ABAQUS	RADIOSS	MADYMO
NASTRAN	PAMCRASH	MOLDFLOW

#### **MESHING:**

Any component having infinite degree of freedom in space and solving problem in such format is just not possible hence we have to convert the infinite degree of freedom component into finite degree component with meshing. Minimum number of independent parameters required specifying its position or motion in a space is known as degree of freedom. With the help of meshing we will able to convert infinite degree of component into finite number of element and nodes. Node is nothing but the reference point for the calculation and element is the ideal shape which is made of connecting different node.

There number of different elements are available for meshing and selection of element is depends upon the application type, accuracy and time available for project based on these parameters we are going to decide the type of element. As number of elements and nodes are increases accuracy on the other hand time required for analysis will be increase. Hence, we need to do

compromise between time required for analysis and accuracy required for selecting mesh size and optimum nodes.

Computational vehicle models need to capture the deformation and interaction of vehicle parts and subsystems occurring during impact. The accuracy with which the crash behavior of a vehicle is simulated depends on the quality of the computer aided design (CAD) data and its meshing. CAD geometry should be accurate in shape and size to resemble the actual vehicle. The FEM mesh should be dense enough to ensure computational convergence and to keep the Computational time reasonably low.

Type of meshing will be going to chance according to application for which we are going to do analysis. For crash analysis we are going to focus more on mesh flow pattern because mass is carried by nodes and stiffness is carried by element. If we do not focus on the mesh flow the at the dense side of meshing mass will be more and at other side mass will be less so that it will not physically correct that's the reason why we are focusing on mesh flow pattern.

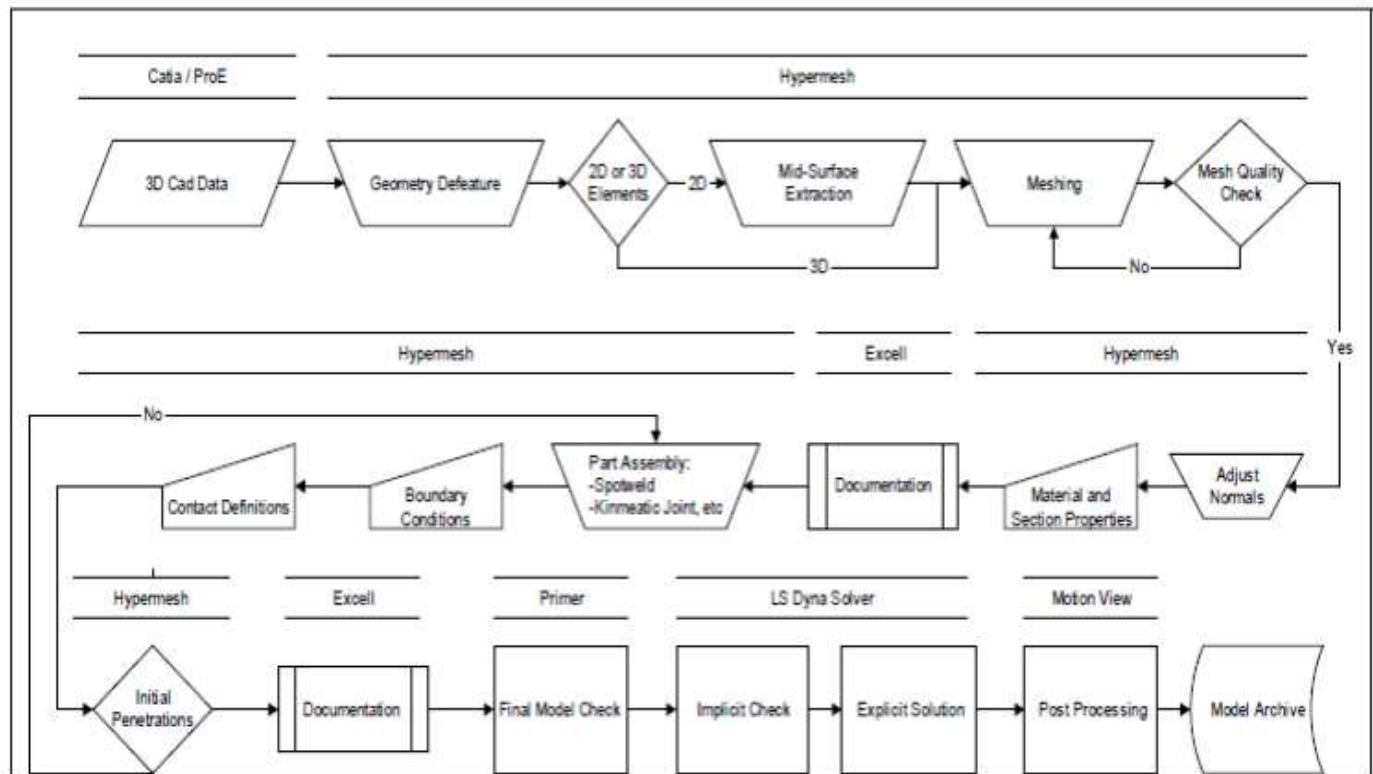

### FE Modeling

Above shows the methodology adopted for the preparation of a finite element model of a bus. For meshing purposes, HyperMesh software was used. HyperMesh is high-performance finite element pre- and post-processor that allows building finite element models, views their results, and performs data analysis. First all CAD models generated in software's like Pro-E and CATIA were converted into IGES format. These CAD models of the bus were provided by the local bus manufacturing company. Then models were called into the HyperMesh. In this software, first mid-surfaces were extracted from these models, as shown in Figure. Then geometry cleaning was done by using options like "geom clean-up" and "defeature" to modify the geometry data and prepare it for meshing operations.

This process involved deletion of holes and curvatures of a very small radius (less than 5 mm), which have less structural significance. The geometries with holes were always difficult to mesh, because they distort mesh generation. Holes with a radius of more than 5 mm were meshed by surrounding it with minimum six elements. Very small parts, like nut-bolts, also were removed from the geometry, and then spot-welds were created in their places to represent bolts, rivets, and welds.

#### LS-DYNA:

LS-DYNA developed by Livermore Software Technology Corporation (LSTC) is a multi-purpose explicit and implicit finite element and multiphysics program used to analyse the nonlinear response of structures. LS-DYNA is a general-purpose finite element program capable of simulating complex real world problem. It is used by the automobile, aerospace, construction, military, manufacturing, and bioengineering industries.

LS-DYNA is optimized for shared and distributed memory UNIX, LINUX and windows based.

LS-DYNA is Highly Compatible for Linear Dynamic Analysis..

## VII. CAR MODEL

- Toyota Yaris Model
- Tata Xenon Pickup Truck Model
- Hatchback Car Model

*Toyota Yaris Model:*

Height	1485 mm
Length	4362 mm
Wheelbase	2570 mm
Width	1695 mm
Cargo Capacity	382 L
Curb Weight	1082 kg
Fuel Tank Capacity	44 L
Gross Vehicle Weight	1516 Kg

Toyota Yaris Model Specifications

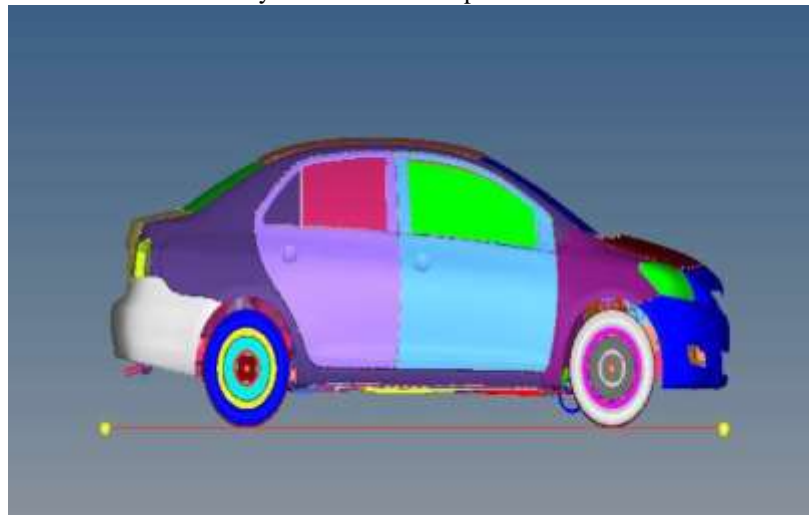

Toyota Yaris Car models side view

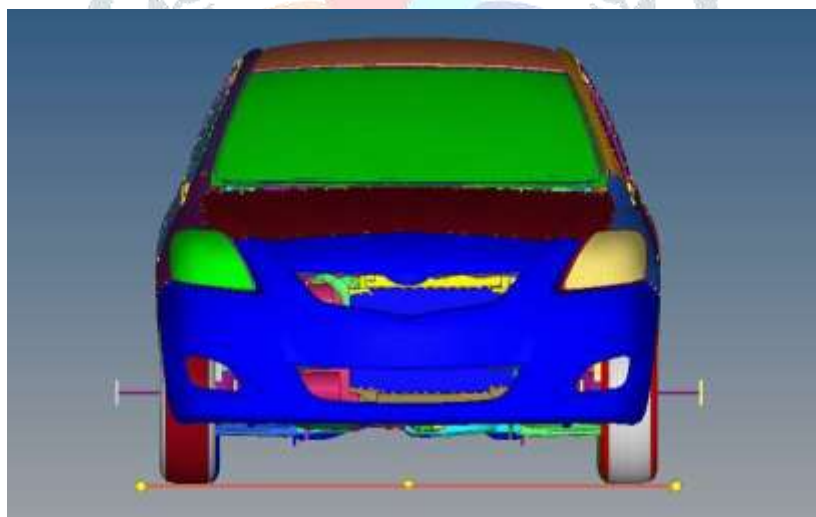

Toyota Yaris Car models front view

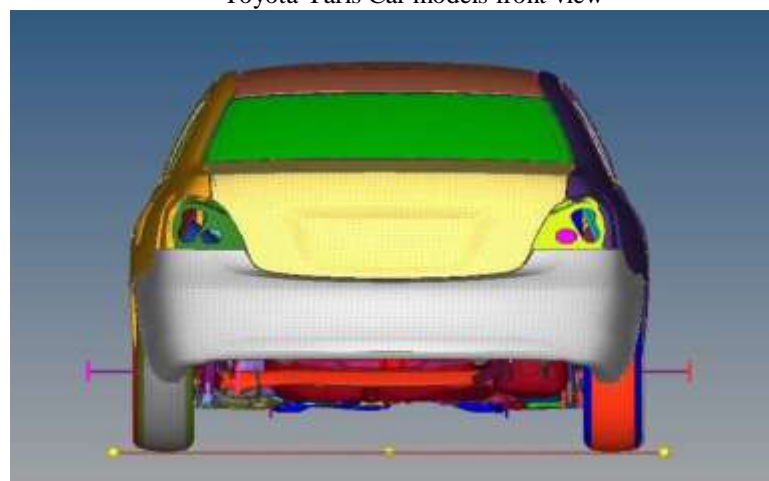

Toyota Yaris Car models back view

**TATA XENON PICKUP TRUCK MODELS:**

Height	1765 mm
Length	5125 mm
Wheelbase	3150 mm
Width	1860 mm
Curb Weight	1920 kg
Fuel Tank Capacity	60 L
Gross Vehicle Weight	2950 Kg

Tata Xenon Truck Specifications

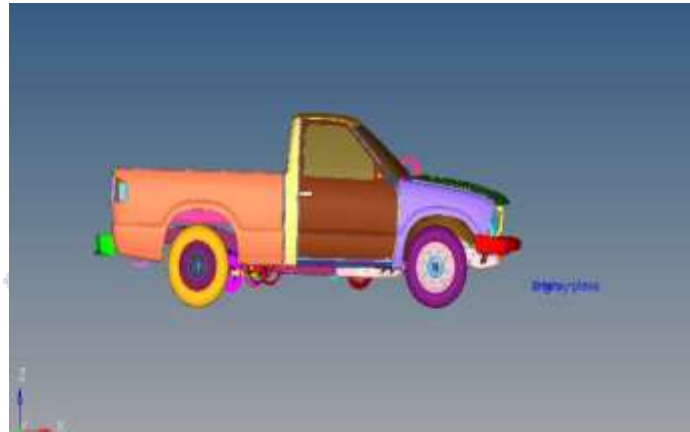

Tata Xenon pickup truck models side view

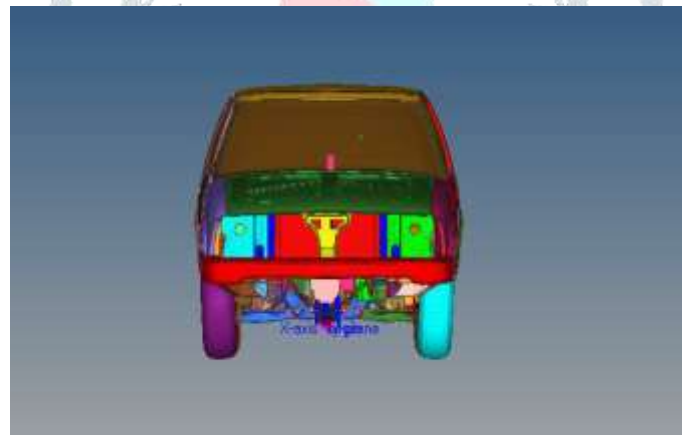

Tata Xenon pickup truck models front view

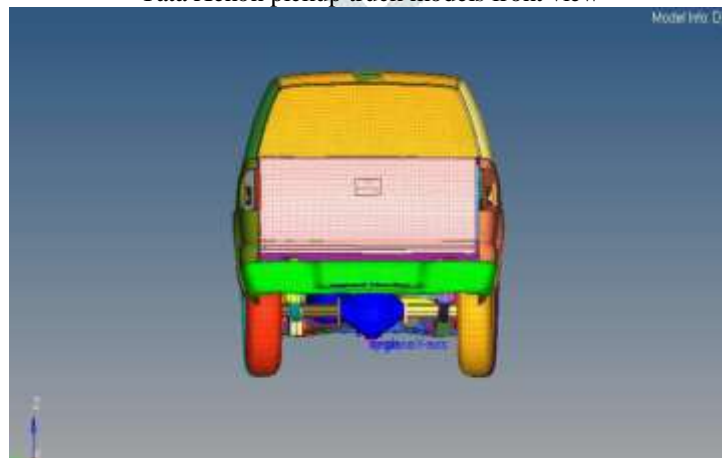

Tata Xenon pickup truck models back view

**VIII. MESHED MODEL**

**MESHING:**

- Meshing is a Process of sub diving the structure to Finite Elements.
- The process of changing the Infinite number of points to Finite Number of nodes and elements. This process is also called as Discretization (Meshing). This is one of the Timing Consuming Process in Finite Element Analysis

**TYPES OF MESHING:**

- 1D meshing (Line meshing).
- 2D meshing (Shell meshing).
- 3D meshing (Tetra / Solid meshing).
- Plastic Meshing

**CRITERIA OF MESHING:**

Criteria		
Target element size: 15		
Checks	On	Fail
Min Size	<input checked="" type="checkbox"/>	5
Max Size	<input checked="" type="checkbox"/>	30
Aspect Ratio	<input checked="" type="checkbox"/>	6
Warpage	<input type="checkbox"/>	15.000
Max Interior Angle Quad	<input type="checkbox"/>	135.000
Min Interior Angle Quad	<input type="checkbox"/>	45.000
Max Interior Angle Tria	<input checked="" type="checkbox"/>	120.000
Min Interior Angle Tria	<input checked="" type="checkbox"/>	30.000
Skew	<input checked="" type="checkbox"/>	40.000
Jacobian	<input type="checkbox"/>	0.600
Chordal Deviation	<input type="checkbox"/>	1.000
Taper	<input type="checkbox"/>	0.600
% of Trias	<input type="checkbox"/>	15.000

3D Criteria

Criteria		
Target element size: 5.000		
Checks	On	Fail
Min Size	<input checked="" type="checkbox"/>	1.500
Max Size	<input checked="" type="checkbox"/>	8.000
Aspect Ratio	<input checked="" type="checkbox"/>	4.000
Warpage	<input checked="" type="checkbox"/>	15.000
Max Interior Angle Quad	<input checked="" type="checkbox"/>	135.000
Min Interior Angle Quad	<input checked="" type="checkbox"/>	45.000
Max Interior Angle Tria	<input checked="" type="checkbox"/>	120.000
Min Interior Angle Tria	<input checked="" type="checkbox"/>	30.000
Skew	<input checked="" type="checkbox"/>	45.000
Jacobian	<input checked="" type="checkbox"/>	0.600
Chordal Deviation	<input type="checkbox"/>	1.000
Taper	<input type="checkbox"/>	0.600
% of Trias	<input checked="" type="checkbox"/>	15.000

Plastic Criteria

Criteria		
Target element size: 5.000		
Checks	On	Fail
Min Size	<input checked="" type="checkbox"/>	2
Max Size	<input checked="" type="checkbox"/>	10
Aspect Ratio	<input checked="" type="checkbox"/>	5
Warpage	<input checked="" type="checkbox"/>	15.000
Max Interior Angle Quad	<input checked="" type="checkbox"/>	135.000
Min Interior Angle Quad	<input checked="" type="checkbox"/>	45.000
Max Interior Angle Tria	<input checked="" type="checkbox"/>	120.000
Min Interior Angle Tria	<input checked="" type="checkbox"/>	25
Skew	<input checked="" type="checkbox"/>	40
Jacobian	<input checked="" type="checkbox"/>	0.600
Chordal Deviation	<input type="checkbox"/>	1.000
Taper	<input type="checkbox"/>	0.600
% of Trias	<input checked="" type="checkbox"/>	5

2D Criteria

**TOYOTA YARIS CAR MESHING:**

- Doing meshing of a car, time taken by me is 6 Months from (June 2019 to November 2019).
- This meshing is done in HYPERMESH Software

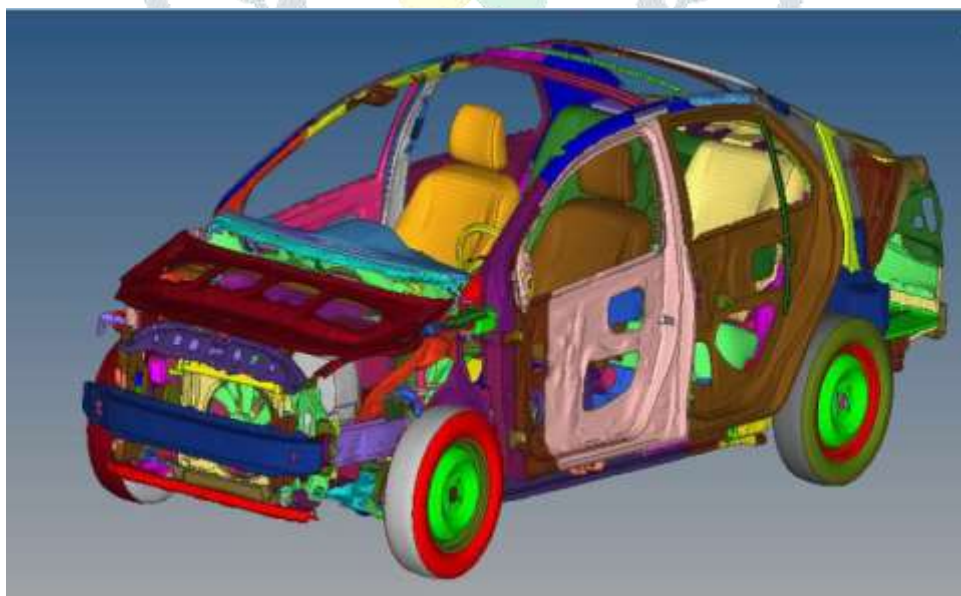

Left side view



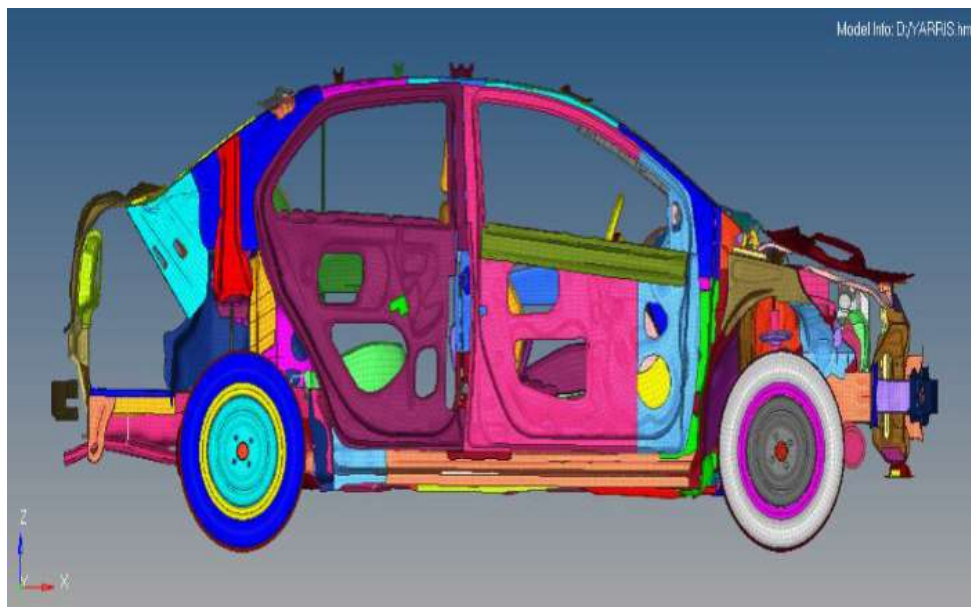

Right side view

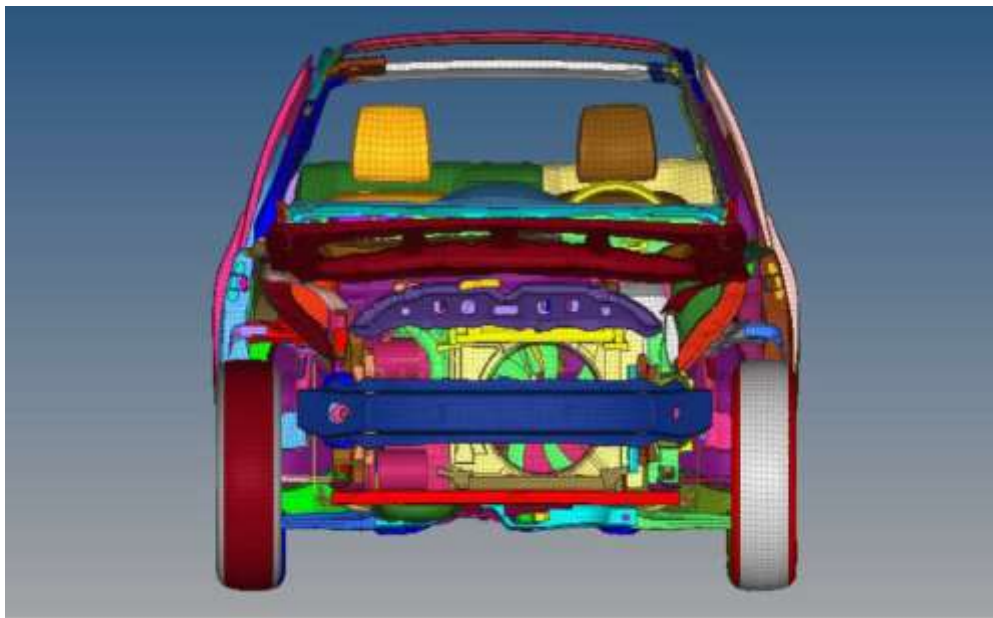

Front side view

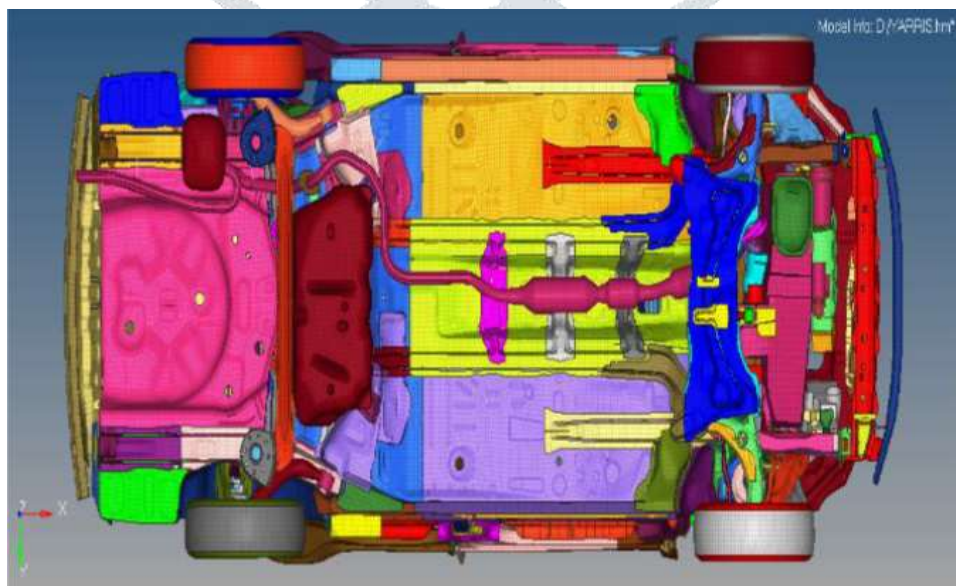

TATA XENON PICKUP TRUCK MESHING:

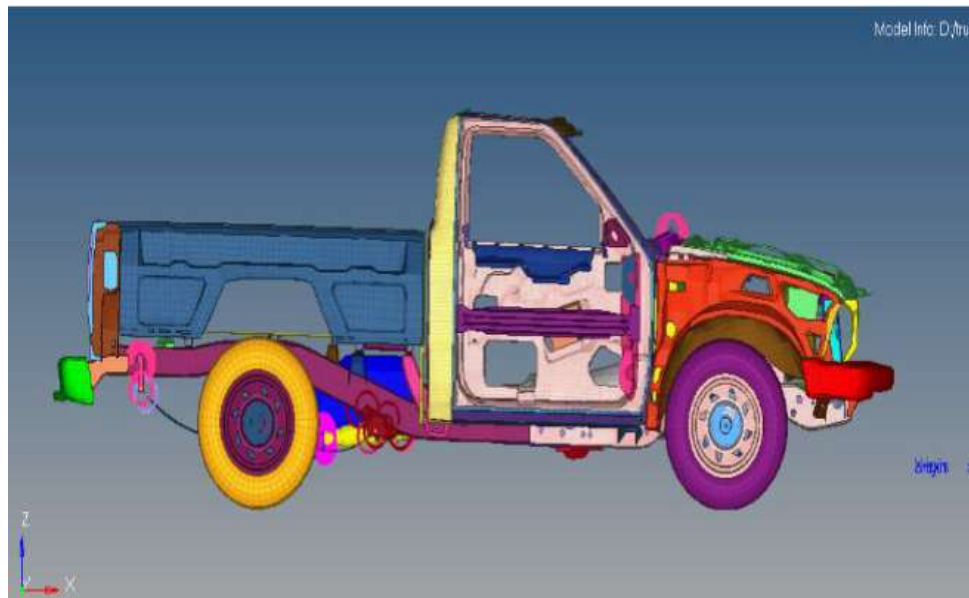

Left side view

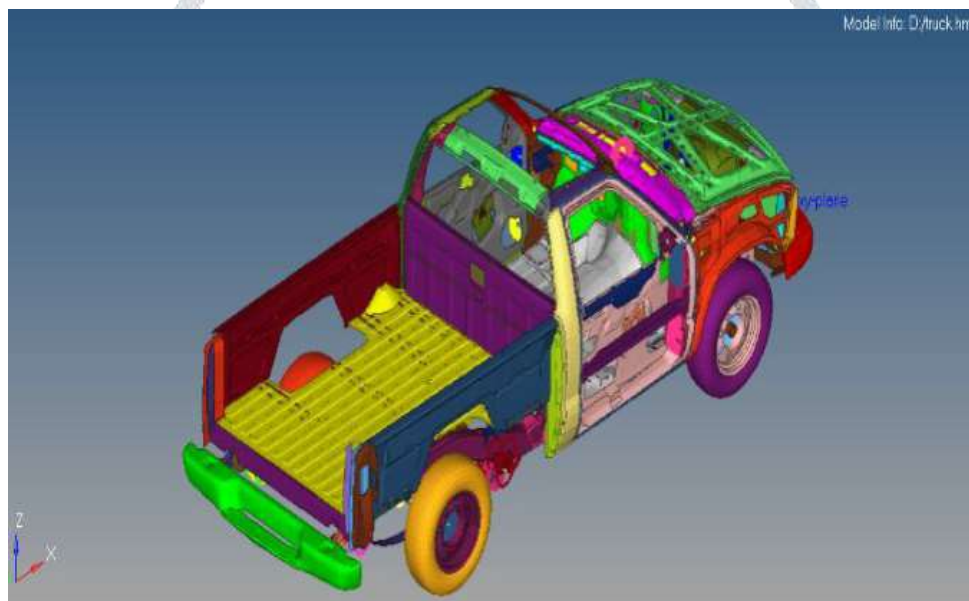

Right side view

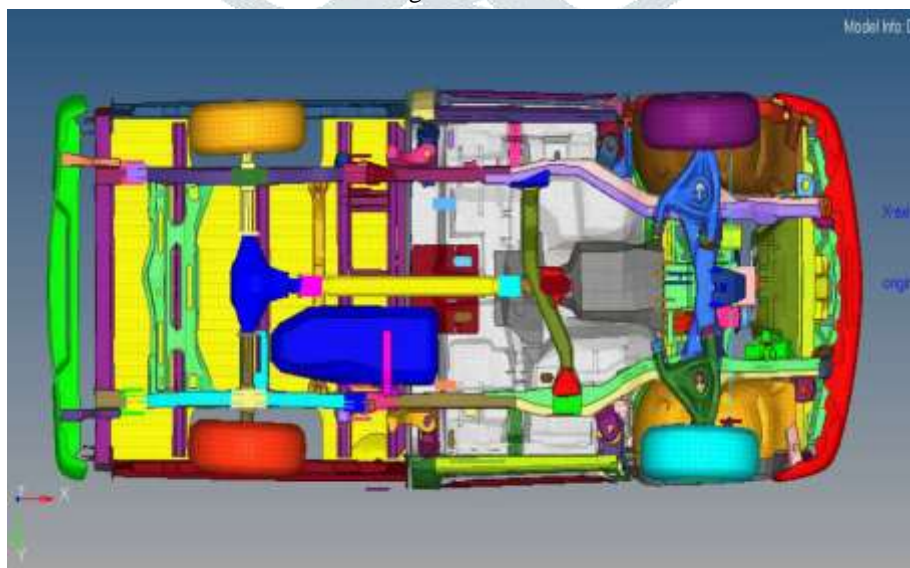

Down side view

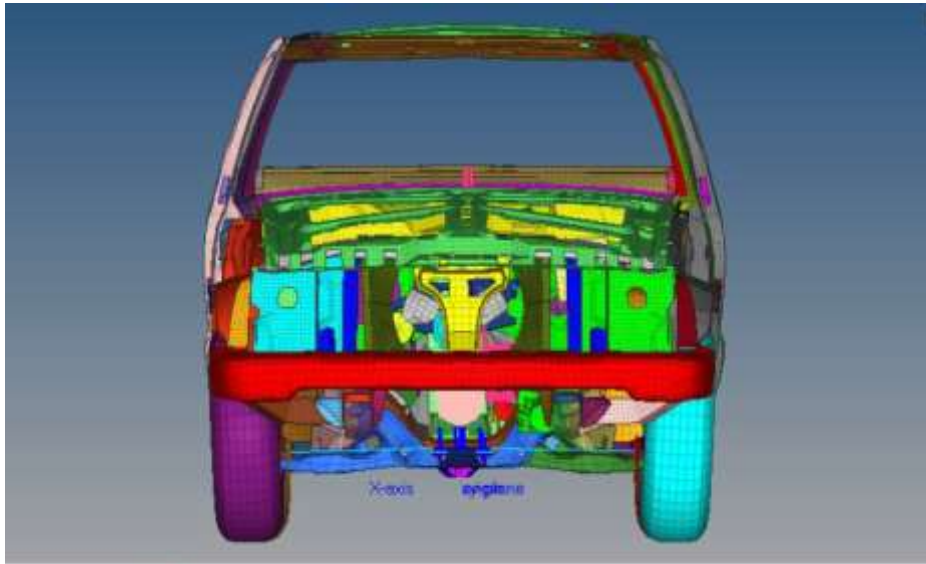

Front side view

## IX. MODIFICATION

### *MODIFYING THE CRUSH BOX:*

- A crush box is an important component in determining crashworthiness of a vehicle
- Crush box is mounted on the rear side of the front and rear bumper and at the time of impact, the crush box will fold like a squeeze box to absorb impact loads and minimize the kinetic energy



Crush Box of Maruti S-Cross



Crush Box Assembly of Maruti S-Cross

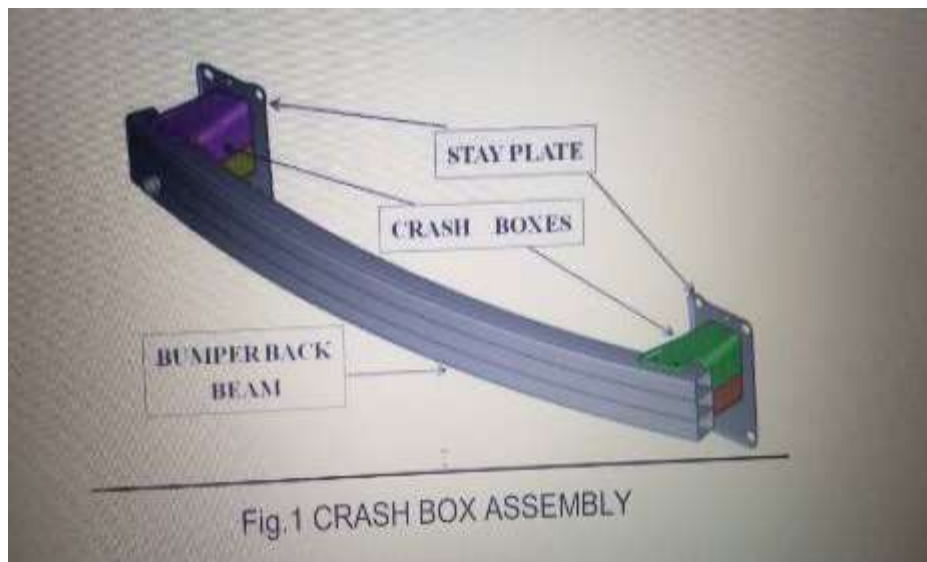

Crash Box Assembly

**DIFFERENT SHAPES OF CRUSH BOX:**

- Square shape.
- Circular shape.
- Hexagonal shape.
- Octagonal shape.

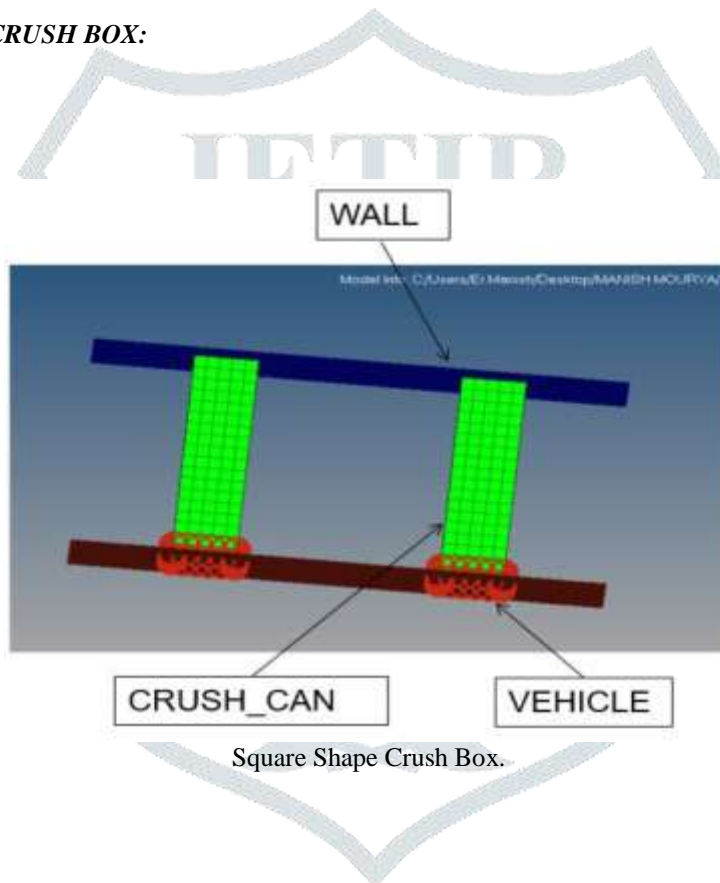

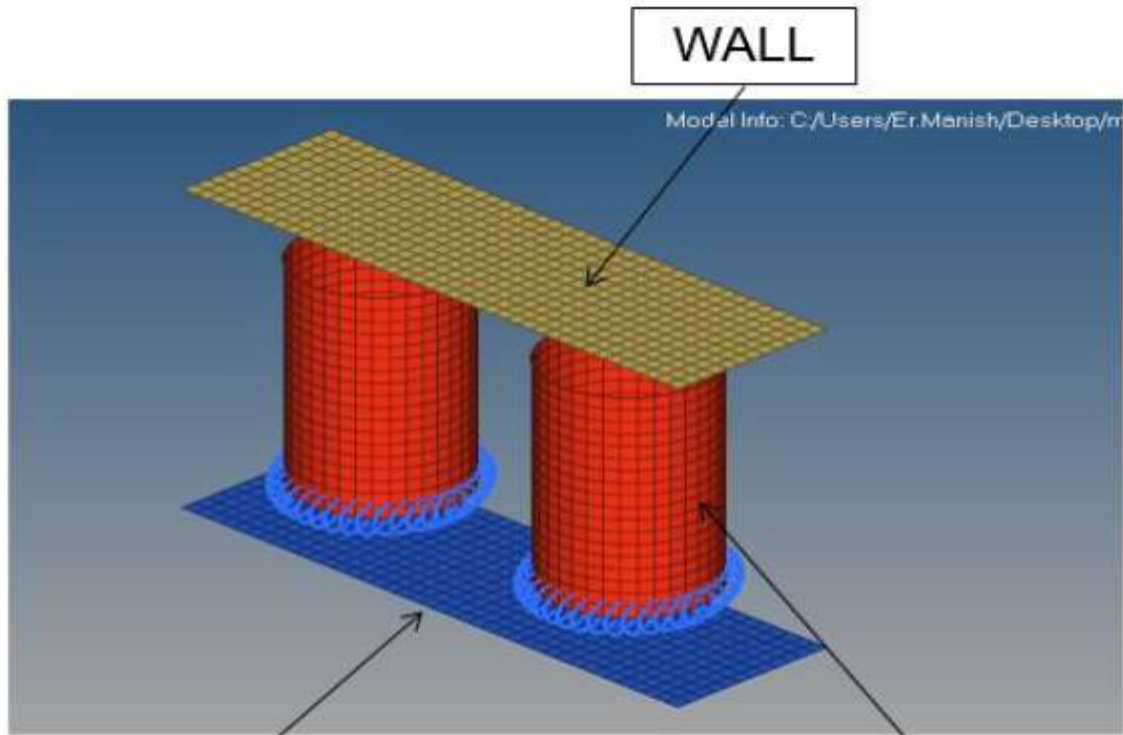

VEHICLE

CRUSH\_CAN

Circular Shape Crush Box

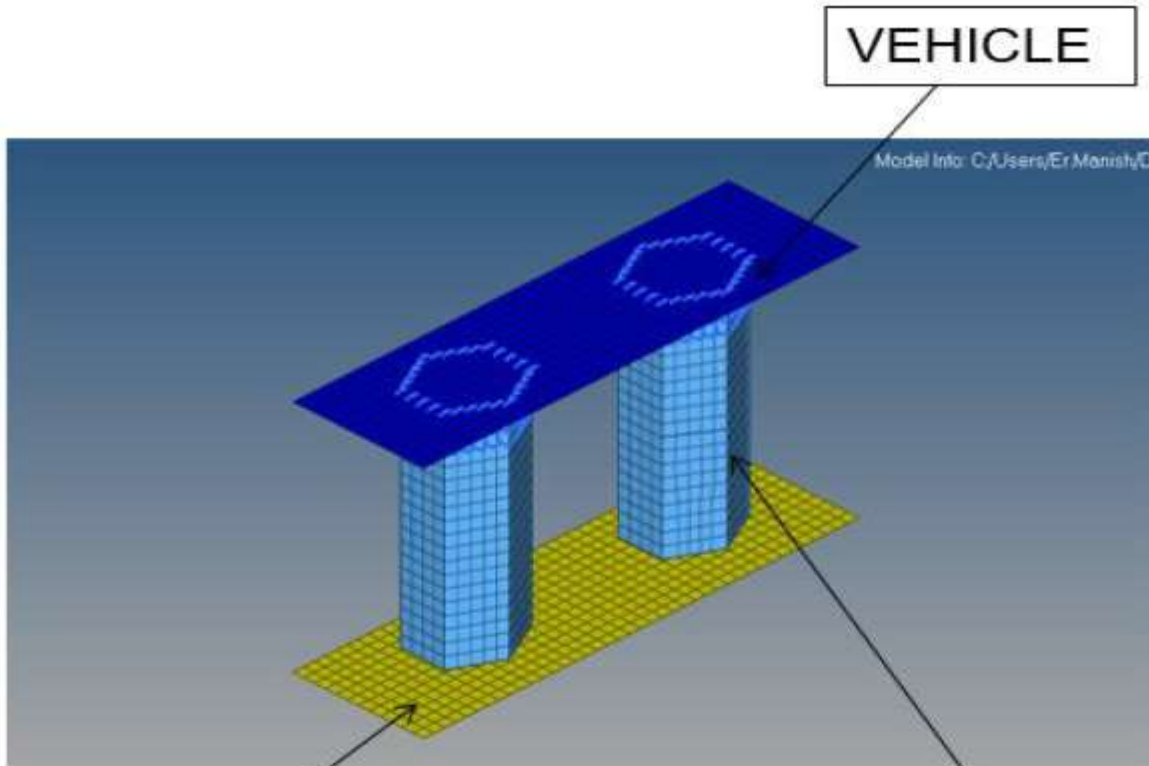

WALL

CRUSH\_CAN

Hexagonal Shape Crush Box

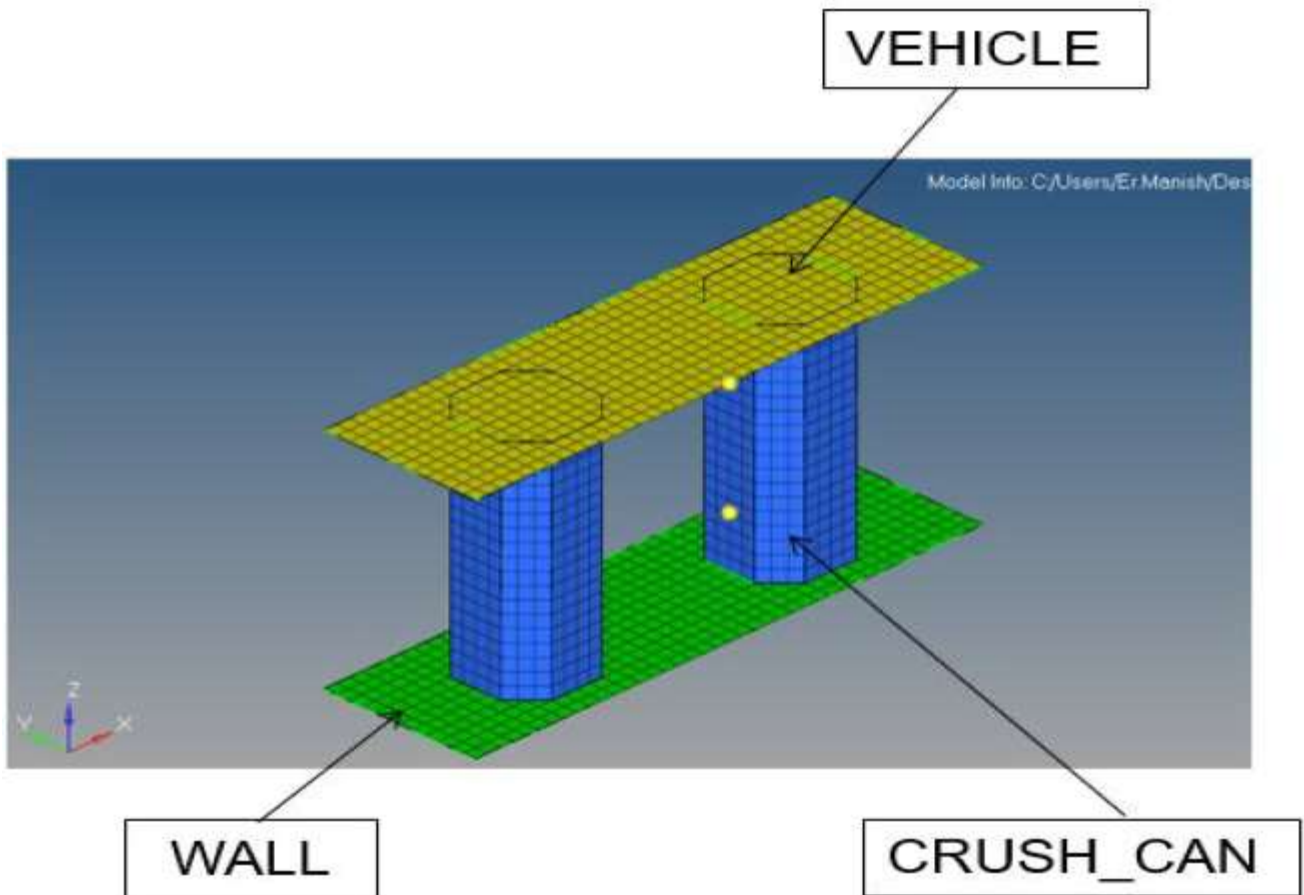

Octagonal Shape Crush Box  
Geometry & Conditions of Crush Can

<b><u>Geometry :-</u></b>	
VEHICLE	60X200X1mm
CRUSH_CAN	24X24X90X0.8mm
WALL	60X200X1mm
<b><u>Meshing :-</u></b>	
VEHICLE	SHELL MESHING
CRUSH_CAN	SHELL MESHING
WALL	SHELL MESHING
<b><u>Materials :-</u></b>	
VEHICLE	MAT 20
CRUSH_CAN	MAT 24
WALL	MAT 20

MAT 20 (Steel) material property

Material Property	Value
Density $\rho$	$\approx 7850 \text{ kg/m}^3$
Unit weight $\gamma$	$\approx 78.5 \text{ kN/m}^3$
Elasticity(E) (Young's modulus)	210000 MPa
Poisson's ratio	0.30

MAT 24 (Elasto-plastic material ) properties

Material Property	Value
Density $\rho$	$\approx 7870 \text{ kg/m}^3$
Elasticity(E) (Young's modulus)	194000 MPa
Poisson's ratio	0.30

Vehicle speed = 10 Km/h

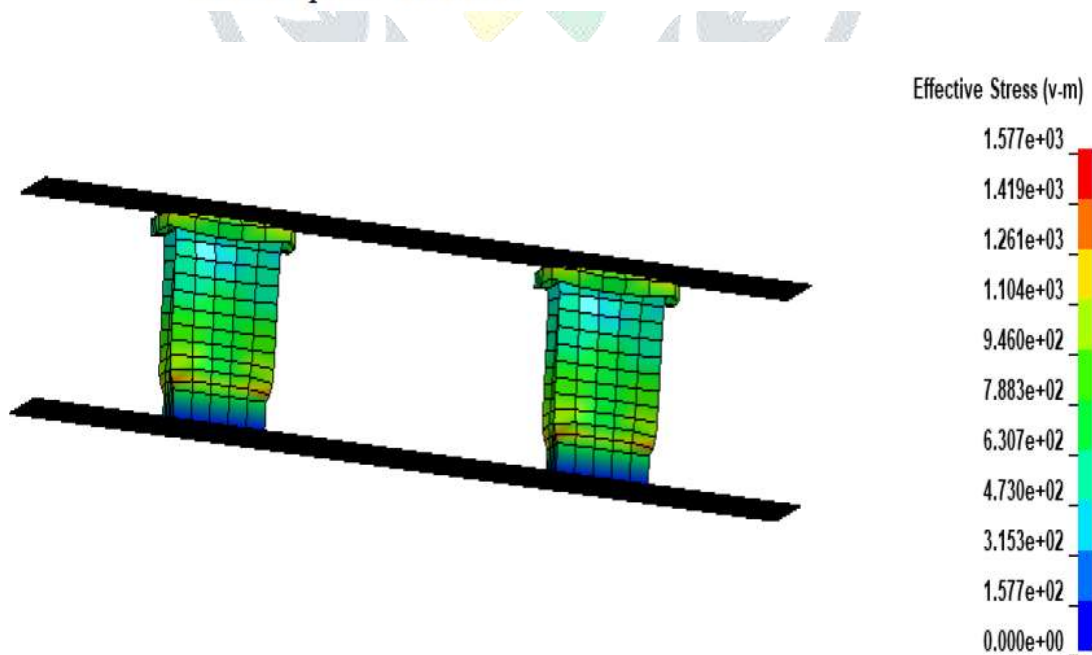

Crash Analysis of Square Shape Crush Can

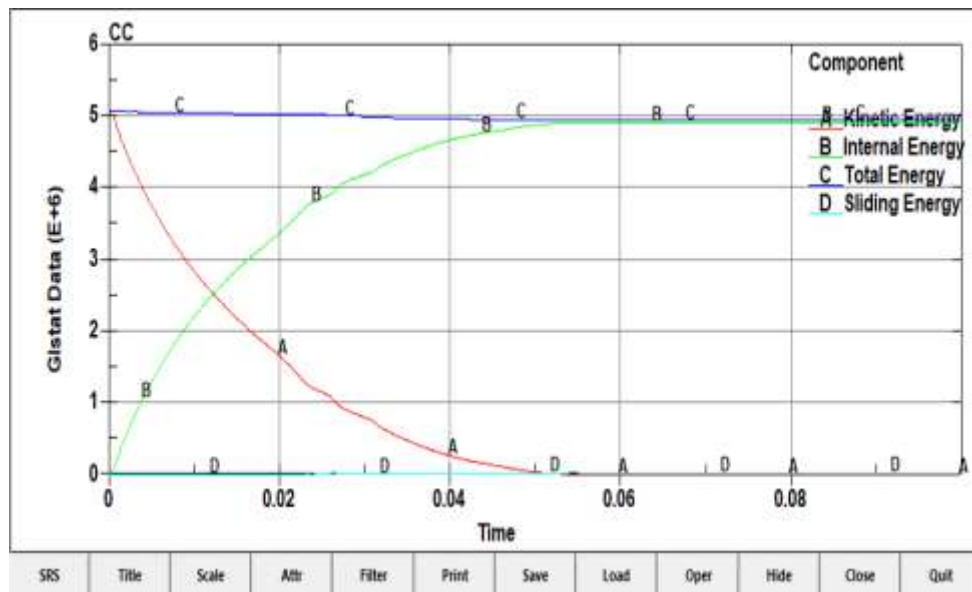

Graphical Representation of Square Shape Crush Can

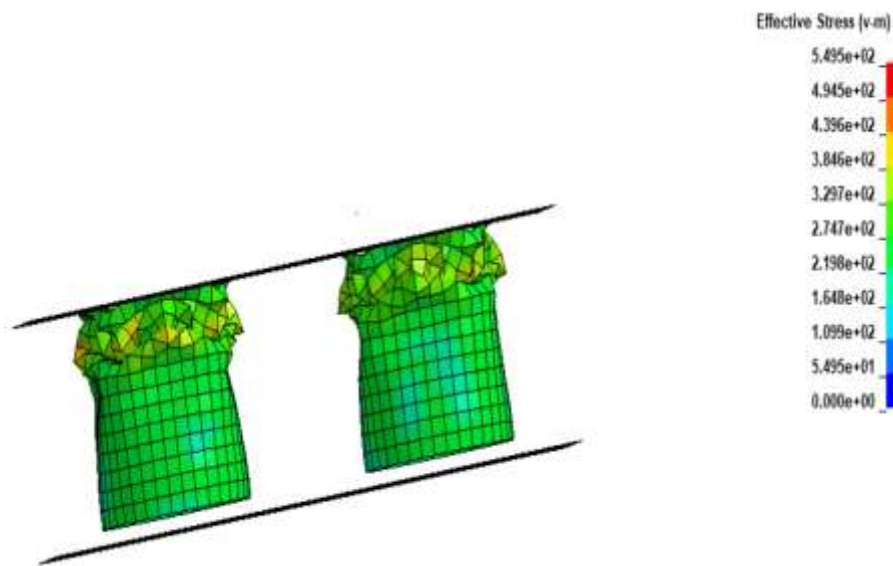

Crash Analysis of Circular Shape Crush Can

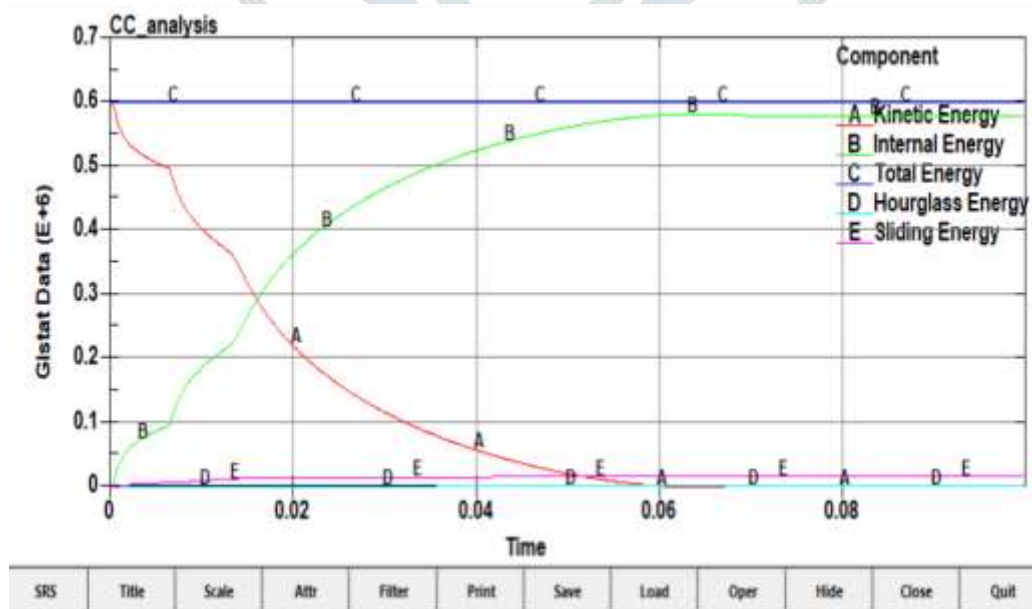

Graphical Representation of Circular Shape Crush Can



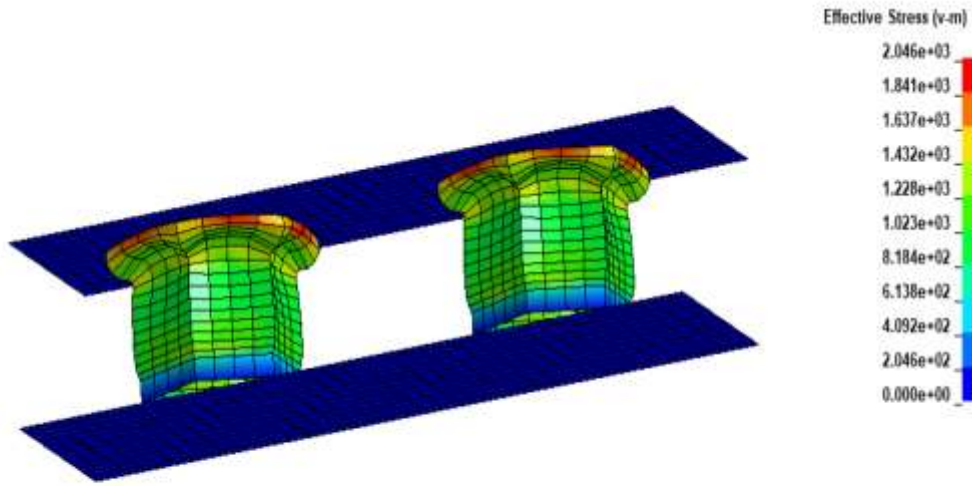

Crash Analysis of hexagonal Shape Crush Can

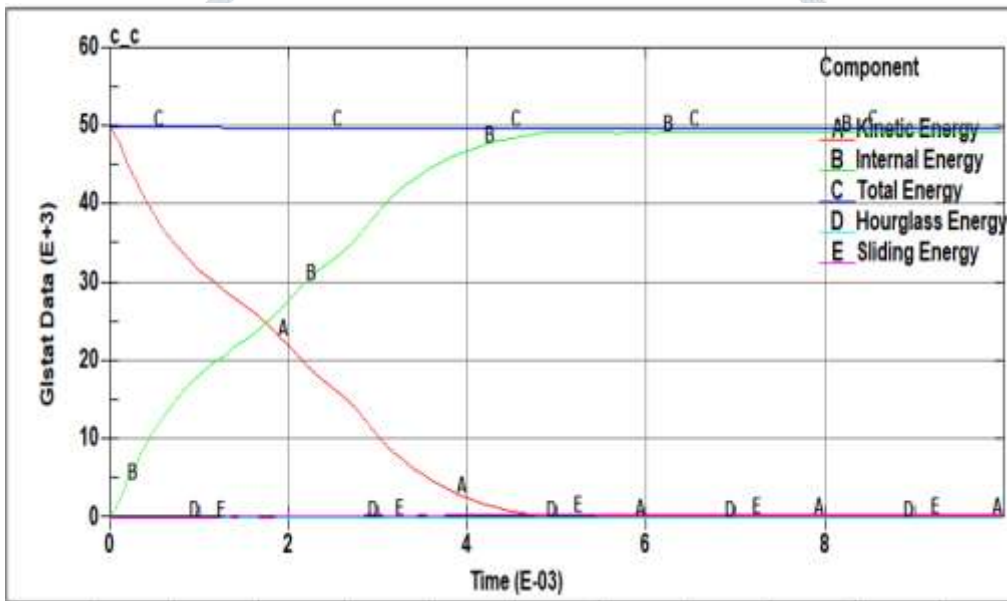

Graphical Representation of Hexagonal Shape Crush Can

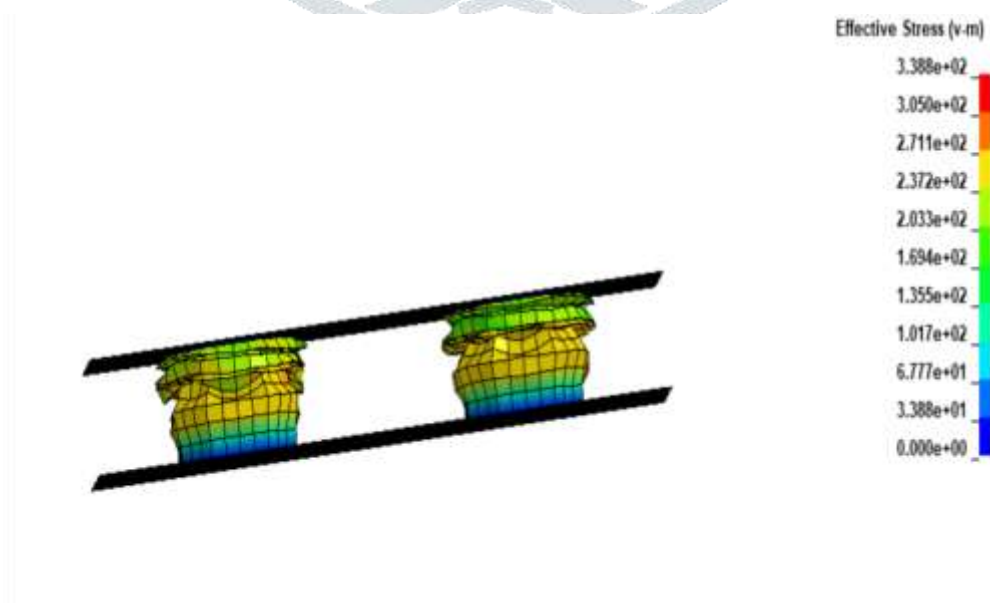

Crash Analysis of Octagonal Shape Crush Can

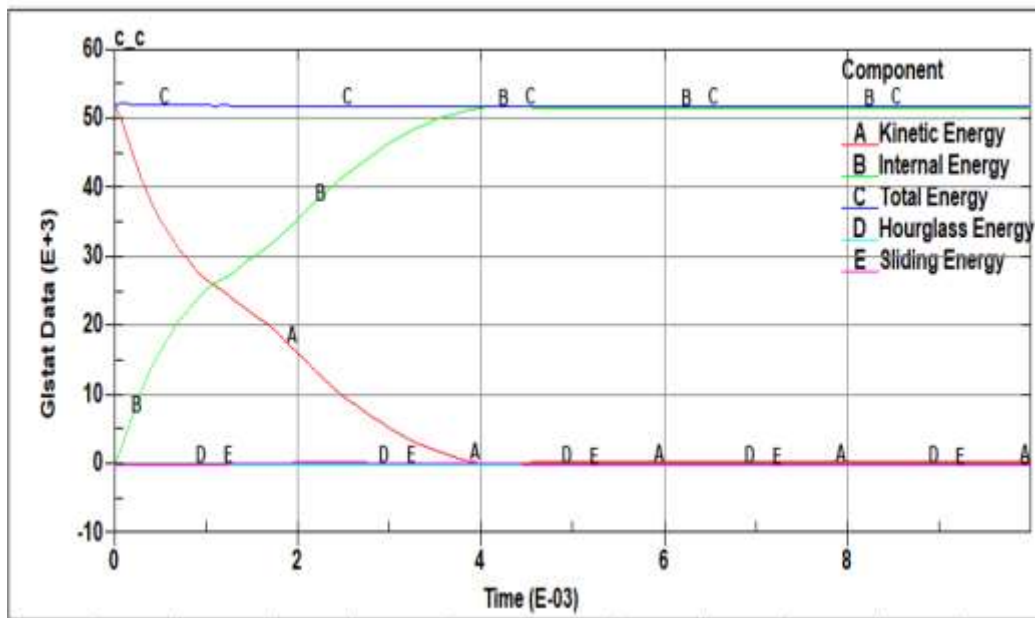

Graphical Representation of Octagonal Shape Crush Can

Comparison of Total Energy

Crush Cans	Total Energy (N-mm)
Square Shape	5.09 N-mm
Circular shape	6.01 N-mm
Hexagonal Shape	5.03 N-mm
Octagonal shape	5.25 N-mm

Comparison of Von Misses Stress

Crush Cans	Von Misses Stress (N/mm <sup>2</sup> )
Square Shape	1577 N/mm <sup>2</sup>
Circular shape	549.5 N/mm <sup>2</sup>
Hexagonal Shape	2046 N/mm <sup>2</sup>
Octagonal shape	3388 N/mm <sup>2</sup>

Comparison of Plastic Strain

Crush Cans	Plastic Strain
Square Shape	1.44
Circular shape	0.4
Hexagonal Shape	1.52
Octagonal shape	2.6

**MODIFICATIONS IN CAR-FRONT STRUCTURE:**

- From engineering experience, the rigidity of energy absorbing plate and spoiler support plate have important effect on pedestrian leg-form injury, thereby making the best possible combination of these components under each leg-form impact conditions.

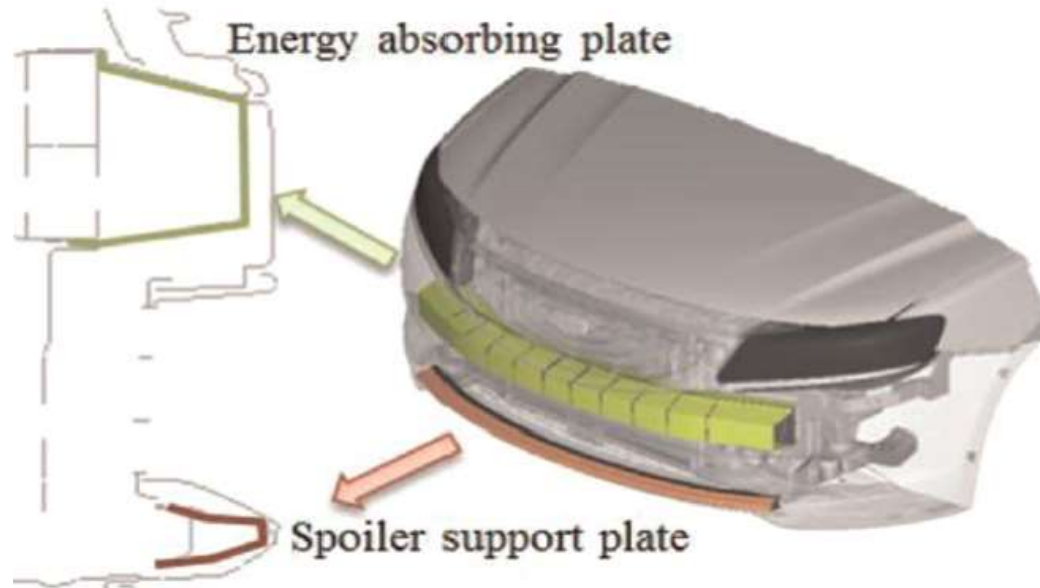

Car frontal structure modification

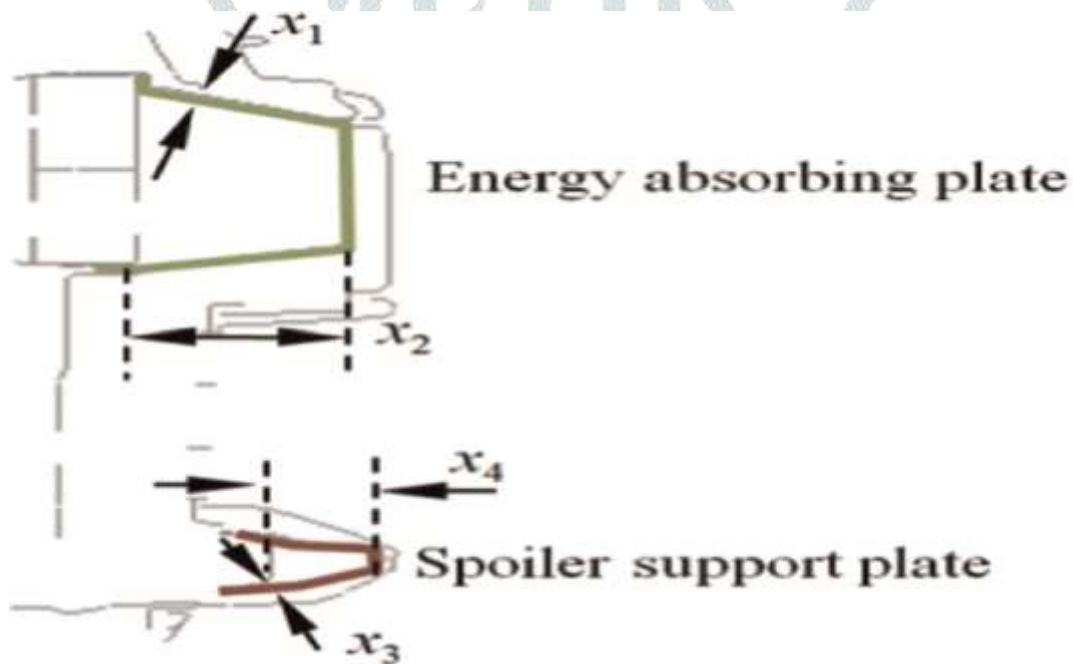

- The thickness of energy absorbing plate ( $x_1$ ), the X-direction distance of energy absorbing plate ( $x_2$ ), the thickness of spoiler support plate ( $x_3$ ), the X-direction distance of spoiler support plate ( $x_4$ ) have significant influences on front-end structure rigidity. Thus, these parameters are taken as design variables.
- Below table provides the list of the design variables, the baseline design values as well as the corresponding lower and upper bounds.
- The normal distribution is the most widely used statistical distribution and can be applied to a wide range of variables Thickness of modification.

The value of the design variables.

Design variations	Distribution	COV ( $\sigma/\mu$ ) (%)	Initial value (mm)	Boundary value	
				Lower (mm)	Upper (mm)
The thickness of energy absorbing plate ( $x_1$ )	Normal	5	1.0	0.6	1.4
The X-direction distance of energy absorbing plate ( $x_2$ )	Normal	5	80	20	100
The thickness of spoiler support plate ( $x_3$ )	Normal	5	1.0	0.6	1.4
The X-direction distance of spoiler support plate ( $x_4$ )	Normal	5	80	20	100

Design variables

## X. TRIAL RUN

In this trial run, we have done pedestrian to vehicle impact at the speed of 40 Km/h, in LS DYNA software, vehicle model is Toyota Yaris with no modification, with Adult leg-form.

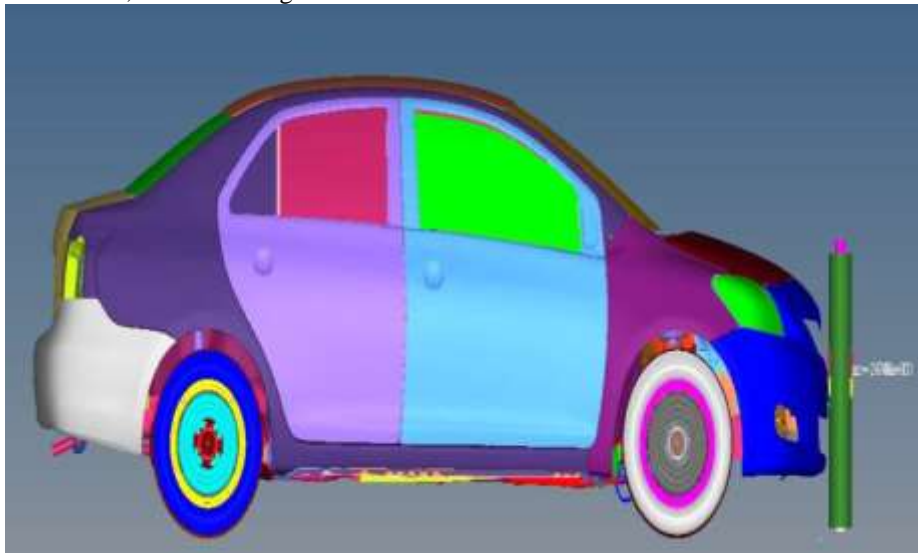

Trial run side view

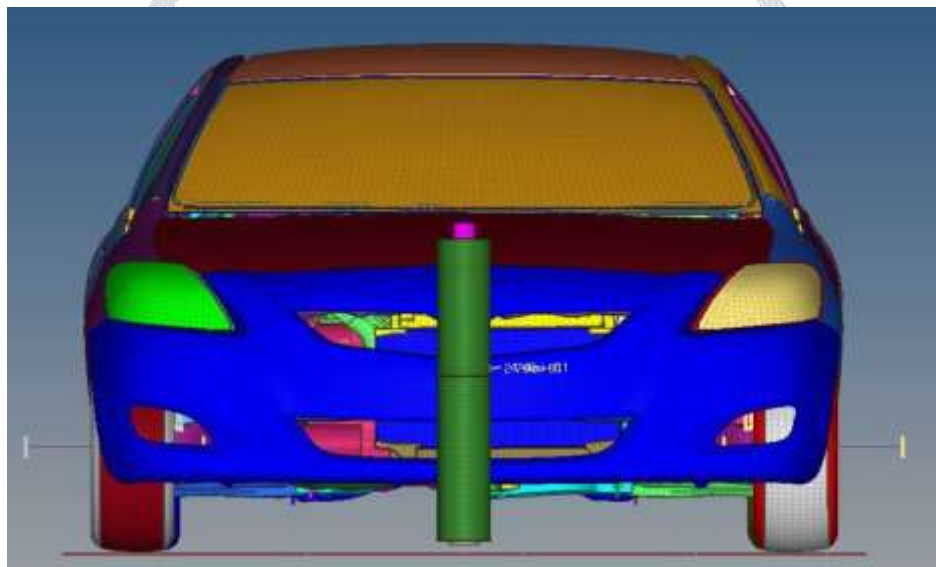

Trial run front view

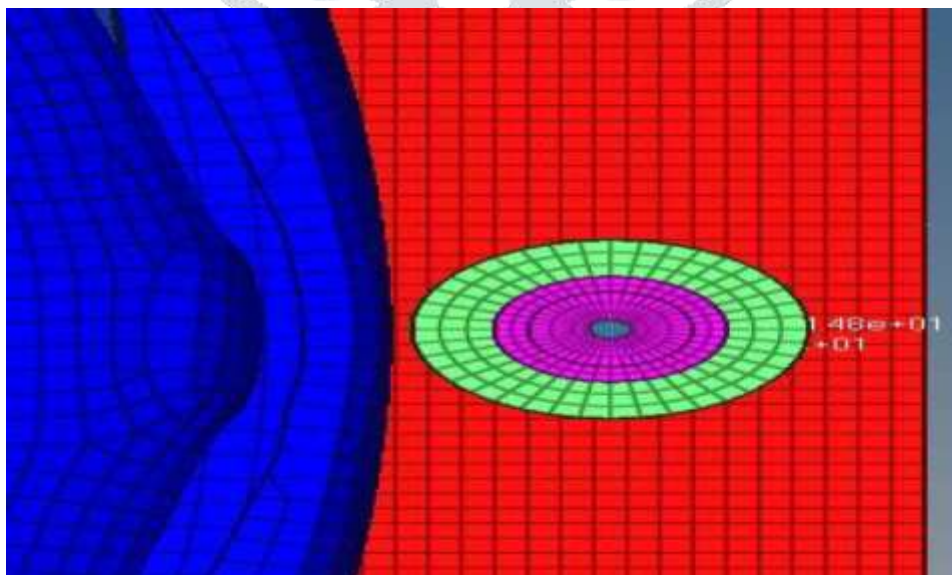

Trial run top view

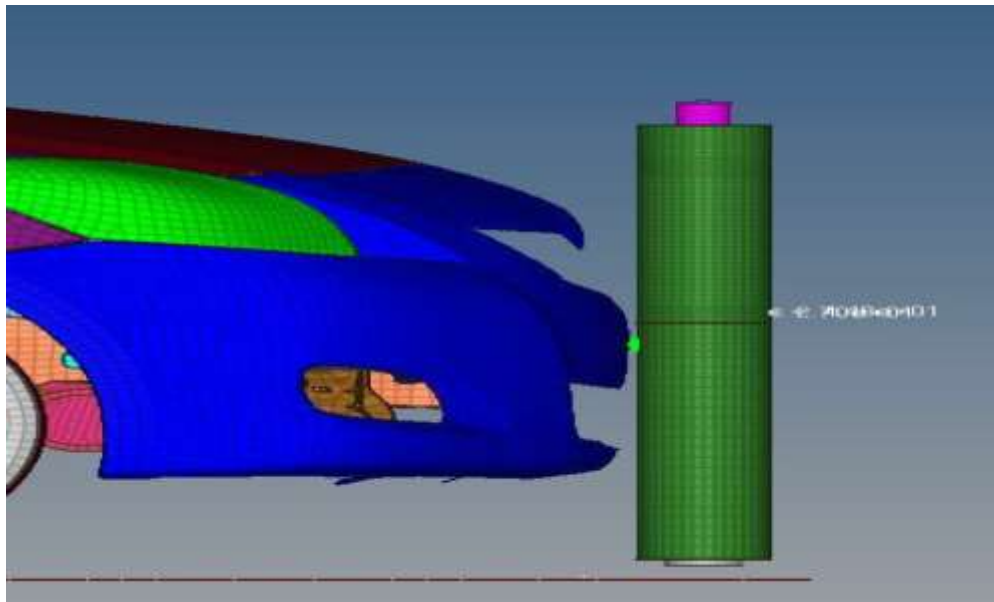

Trial run close view

**LEG-FORM OF PEDESTRIAN:**

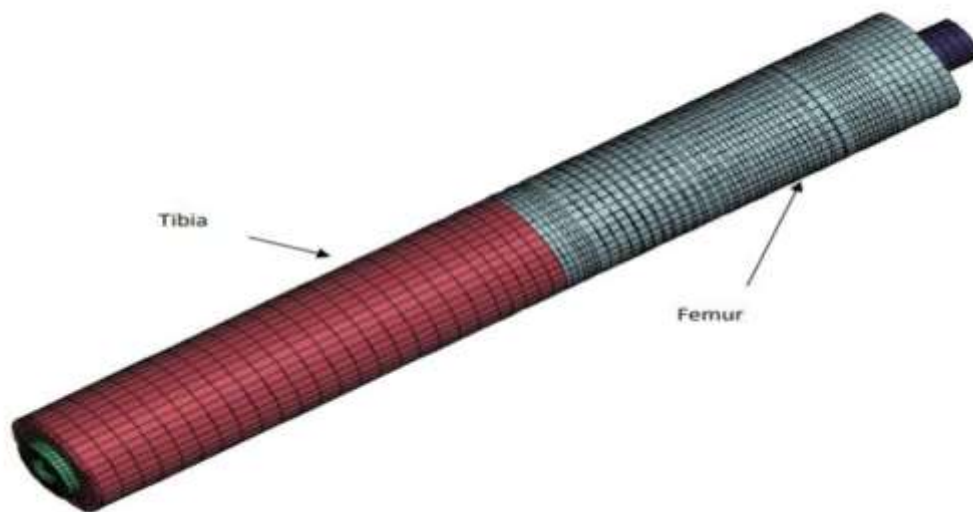

3D leg form view

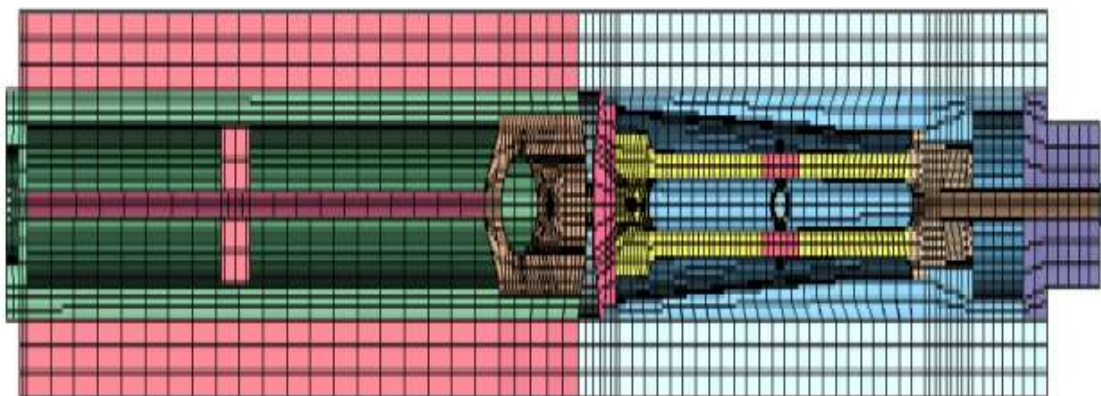

Section cut leg form view

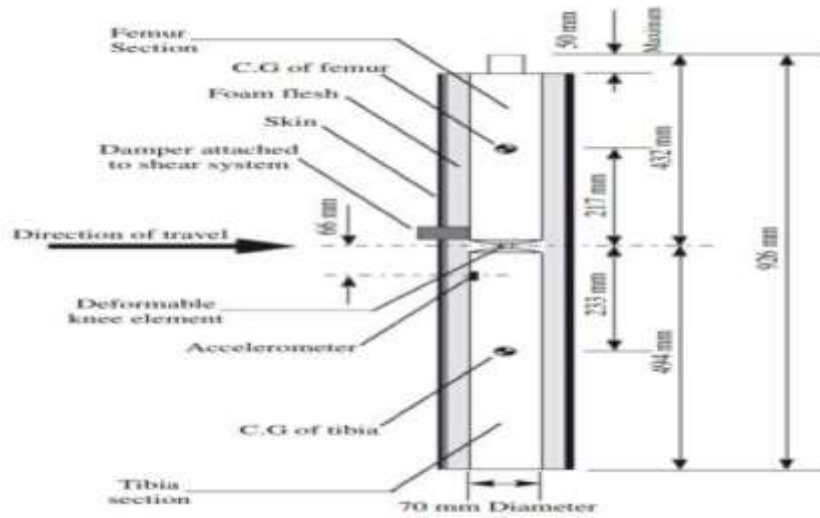

Geometrical View

**DESIGN PARAMETERS OF RUNS:**

- Impact Speed is 11.1 m/s (40 km/hr) .
- Dynamic knee bending angle < 190 .
- Knee shearing displacement < 6mm.
- Acceleration at upper tibia < 170g.
- Mass of femur = 8.6 kg.
- Mass of tibia = 4.8 kg.
- Mass of leg-form = 13.4 kg.
- Diameter of leg-form = 70mm.
- Length of femur = 432mm.
- Length of tibia = 492mm.
- Total length of leg-form = 926mm.
- Inertia of femur = 0.08611 kgm<sup>2</sup>.
- Inertia of tibia = 0.0556 kgm<sup>2</sup>.
- Leg-form material = MAT\_83 (MAT\_FU\_CHANG\_FOAM).
- Bumper material = MAT 24 (ABS\_PLASTIC) Acrylonitrile butadiene styrene plastic.
- Above parameters to be used as constraints in the optimization process of a bumper system

**DESIGN OF LEG-FORM:**

The Leg form meshing is done in HYPERMESH Software.

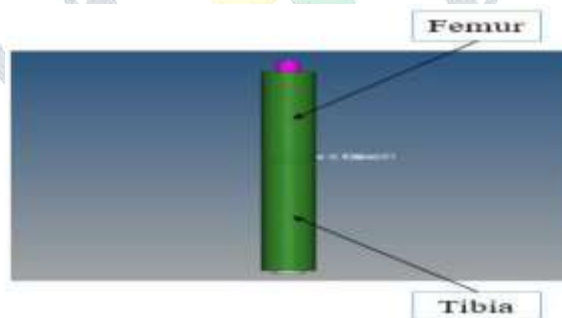

Femur and tibia view

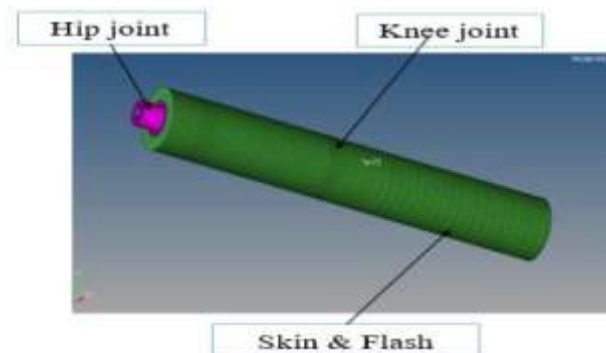

Knee joint view

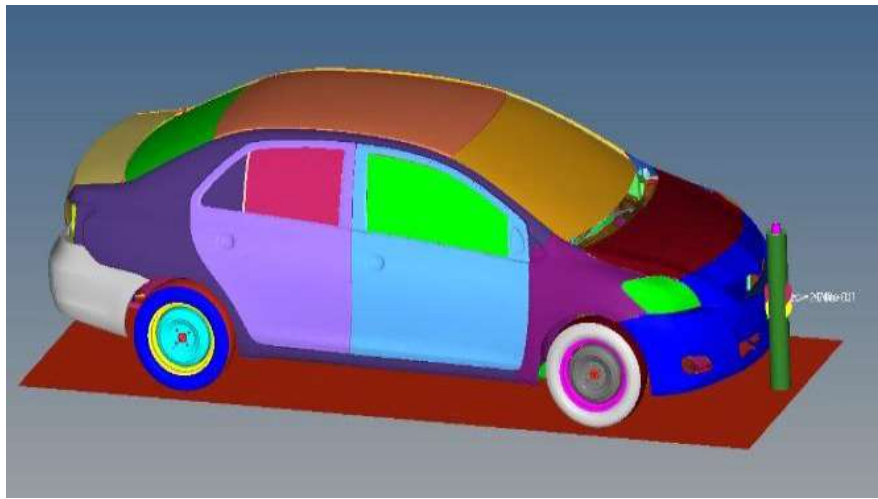

Trial run over view

- 0.1 mm gap between Car and Leg-form
- 25 mm gap between Leg-form and floor

**XI. CONCLUSION AND OBSERVATION**

- In Trial-1 model, the car front was getting crushed after impact and leg-form would remain static with no signs of stresses.
- This scenario did not occur in Trial-2 model for same velocity (40 Kmph).
- As seen in trial run, the leg-form gets bent at knee joint location after impact and car front is only slightly damaged.
- Therefore, we can conclude that present model setup is correct and will be used for all tests under R-127 regulation henceforth.

**XII. ACKNOWLEDGMENT**

I would like to convey my heartfelt gratitude to my mentor, for his invaluable advice and assistance in completing my project paper. He was there to assist me every step of the way, and his motivation is what enabled me to accomplish my task effectively. I would also like to thank all the other supporting personnel who assisted me by supplying the equipment that was essential and vital, without which I would not have been able to perform efficiently on this project.

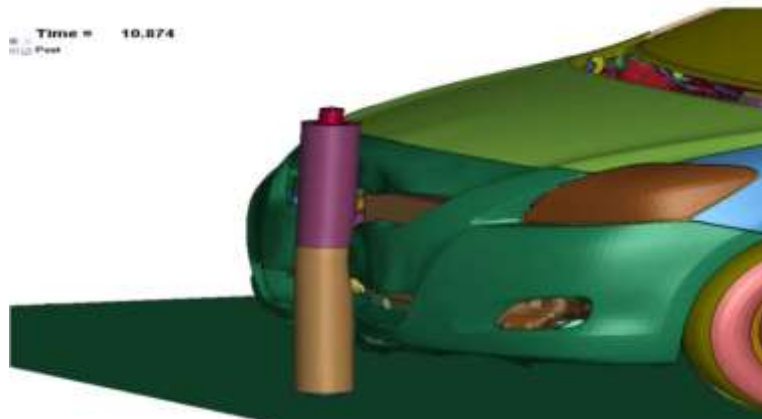

Trial run-2 close view

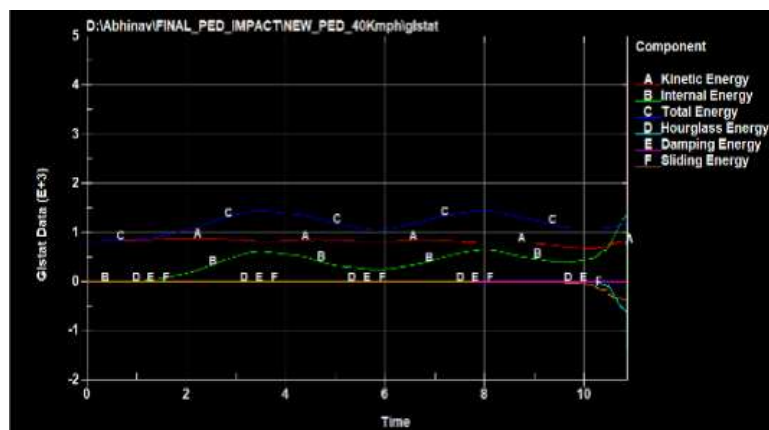

Energy graph

**REFERENCES**

- [1] G. S. e. al, "An Enhanced Methodology for light weighting a vehicle design consideration front crashworthiness and pedestrian impact safety requirements", 11th International Symposium on Plasticity and Impact Mechanics, 2017
- [2] K. T. e. al, " Accident Characteristics In Car To Pedestrian Impacts", GDV Institute of Vehicle Safety, Munich
- [3] D. R. e. al, " Pedestrian And Their Survivability At Different Impact Speeds", Loughborough University, United Kingdom
- [4] C. Catherine Masson et al, "Pedestrian Vehicle Accident Analysis Of 4 Full Scale Tests With PMHS" , French National Institute for Transport and Safety Research, France
- [5] E. R. e. al, "literature review of pedestrian fatality risk as a function of car impact", Accident Analysis and Prevention, 2011
- [6] M. M. Ptak et al, " the influence of frontal protection system design on pedestrian passive safety" , Archives Of Civil And Mechanical Engineering, 2011
- [7] D. G. T. e. al, "Computational And Experimental Analysis Of Head Injury Criteria (HIC) In Frontal Collision Of Car With Pedestrian", SAE International, January 2019
- [8] D. B. e. al, "Performance Assessment Of Pyramidal Lattice Core Sandwich Engine Hood For Pedestrian Safety", SAE International, October 2019
- [9] J. S. G. e. al, "Injury Reduction in Vehicle to pedestrian collision" SAE International, November 2019
- [10] I. K. e. al, "Optimal Design of Light Commercial Vehicle Headlamp For Pedestrian", International Conference On Computational And Experimental Science And Engineering (ICCESEN), 2016
- [11] Y. M. e. al, "A 6-Year-Old Pedestrian Finite Element Model For Simulating Pedestrian Impacts", 14th International Ls-Dyna Users Conference. 2016

**BIOGRAPHIES**

Pravin Vijay Lohot <sup>1</sup>  
(ME design)

Department of Mechanical Engineering  
Jaihind College of Engineering Kuran,  
Savitribai Phule University,  
Pune, India

[Pravinlot007@gmail.com](mailto:Pravinlot007@gmail.com)

