



## A Comprehensive Computational Fluid Dynamics (CFD) based Analysis of the variable surface roughness effect on heat transfer rate in counterflow Heat Exchanger using Solid Works

<sup>1</sup>Gurpreet Kour, <sup>2</sup>Dr. Ranjit Singh, <sup>3</sup>Munish Baboria

<sup>1</sup>M. Tech Research Scholar, <sup>2</sup>Associate Professor, <sup>3</sup>PhD Research Scholar

<sup>1</sup>Mechanical Engineering Department,

<sup>1</sup> Beant College of Engineering and Technology, Punjab, India

**Abstract :** Heat transfer has become one of the basic needs in the manufacturing and refrigeration industry. Optimizing system performance and minimizing the use of available resources is always been the focus of researchers. Therefore, in this study, it was decided to conduct a Computerized Fluid Dynamics (CFD) based study on heat transfer variations in terms of properties of thick materials using rings as roughness geometry. An electronic exchange model was developed in Solidworks to generate the roughness of the inner tube. The effect of surface roughness on the efficiency and friction coefficient of counterflow heat exchangers was analysed. In addition to it, to predict the performance of counterflow heat exchanger, the dependence of efficiency and friction coefficient as a function of Reynolds number and relative roughness height has been established. The data so obtained through CFD simulation was in good agreement with predictions based on design value and friction coefficient.

**Index Terms -** Computational fluid dynamics (CFD), counterflow, heat exchanger, Reynold number, simulation, Solidworks, surface roughness, tubes.

### I. INTRODUCTION

A heat exchanger is a mechanical device which transfers thermal energy of one fluid at high temperature to other fluid at lower temperature by means of convection without any external heat and work interaction. The sole purpose of the heat exchanger is to control the temperature of the system or product by simply adding or removing heat energy. Although different heat exchanger can come in many different shapes, sizes, and types, they all use an electrical device, usually a tube or plate, that separates two fluids so that one fluid can transfer thermal energy to the other. Heat exchangers are used in combustion engines, space heating, air conditioning, power plants, chemical plants, petrochemical plants, refineries, natural gas processing, etc. The performance of the heat exchanger can be improved by adding fins, metal inserts or grooves in one or both directions.

### 1.2 Classification of Heat Exchangers

Heat exchangers are classified on various parameters and configurations but some most commonly used classification is given as under:

#### 1.2.1 According to heat transfer method.

##### 1.2.1.1 Indirect Contact Heat Exchanger

In an indirect contact heat exchanger, water streams remain separate and heat is transferred either continuously through an impermeable bulkhead wall or on a delayed basis to the wall. So ideally there is no direct contact between thermally interacting fluids. This type of heat exchanger is also known as surface heat exchanger, and can also be divided into direct heat exchanger, storage and fluidized bed exchanger.

##### 1.2.1.2 Direct Contact Heat Exchanger

In a direct contact heat exchanger, two fluids come into direct contact, exchange heat, and then separate. Direct contact applications involve further conversion through the use of heat, such as evaporative cooling and distillation. Phase changes often cause changes in temperature. Compared with indirect contact heat exchangers and regenerators, direct heat exchangers can achieve high heat transfer rates, and different power models are relatively inexpensive.

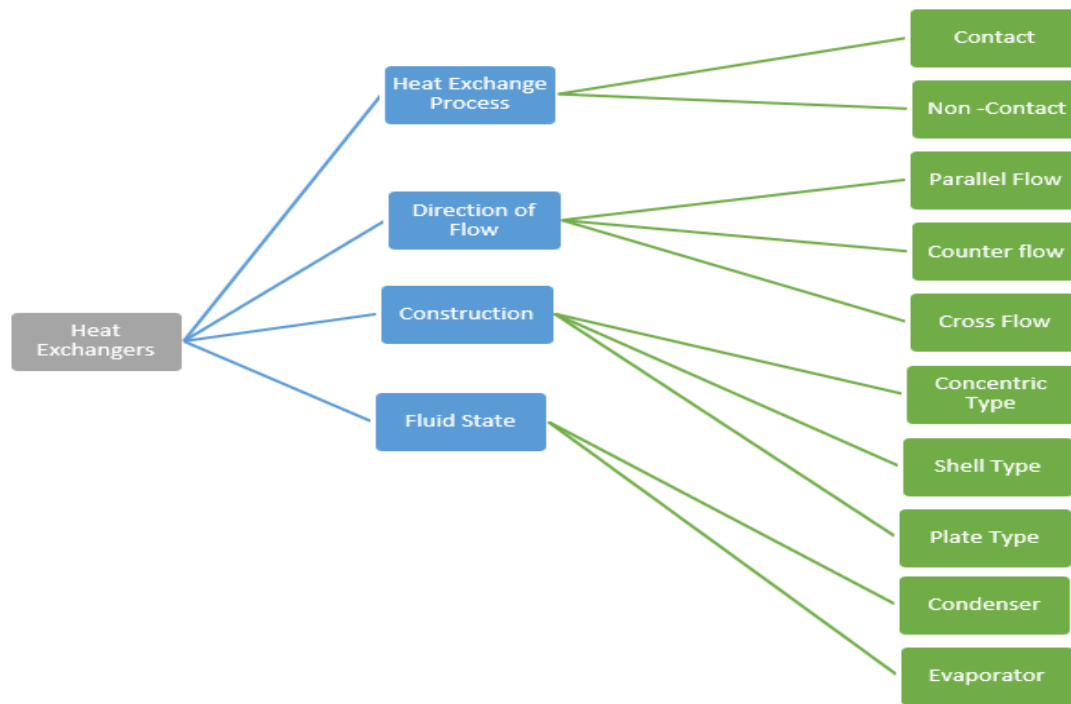

Fig 1. Classification of Heat exchangers

## 1.2.2 According to relative flow direction of hot and cold-water flow

### 1.2.2.1 Parallel Flow Exchanger

In a parallel flow exchanger, fluids enter together from one end, flow to each other in the same direction, and leave together from the other end. This arrangement has the lowest efficiency of all electrical equipment connected to an electrical circuit for drainage and water intake; in terms of temperature; However, some operations may be less efficient.

### 1.2.2.2 Counterflow exchanger

In a counterflow or counterflow exchanger, two fluids flow toward each other but in opposite directions in the core. In such a change, the temperature change between the two fluids may be good for a long time. For a given total heat transfer fluid flow and water inlet temperature at the exchanger wall thickness (between the exposed wall of the exchanger), it is the best adequate flow arrangement compared to other two-fluid flow arrangements to maximize temperature. change in every liquid. Hot fluid side and cold-water side) It is the lowest temperature of the hot fluid side or cold water side and creates the least thermal stress on the wall, providing the same performance as the other process. However, there are manufacturing issues associated with the correct counterflow arrangement for plate heat exchanger surfaces. This is due to the need to isolate the fluid at both ends and the complexity of the inlet and outlet header design.

### 1.2.2.3 Cross-flow heat exchanger

In this type of heat exchanger, two fluids flow in the opposite direction to each other. Heat transfer fluid only comes in two sizes for inlet and outlet. Thermodynamically, the efficiency of alternating current is the source of the current competition and mutual current. The temperature difference is greatest in the corners where hot and cold water enters. This is one of the most convenient arrangements used for the connection of continuous electrical equipment because it is very easy to create a header for the inlet and outlet of each fluid. If the demand for variable energy is high (e.g. more than 80%), the size of alternating current will be exceeded. In this case, the countercurrent unit is preferred.

## 1.2.3 According to Constructional Features

Heat exchangers are frequently characterized by construction features. Four major construction types are concentric heat exchangers, shell and tube heat exchangers, plate-type heat exchangers, extended surface heat exchangers and regenerative exchangers.

### 1.2.3.1 Concentric heat exchangers

In concentric tube type heat exchanger, one tube remains located inside another tube. One fluid flow through the inner tube and other fluid flows through annular space between the tubes.

### 1.2.3.2 Shell and tube exchangers

This exchanger is generally built of a bundle of round tubes mounted in a cylindrical shell with the tube axis parallel to that of the shell. One fluid flows inside the tubes, the other flows across and along the tubes. The major components of this exchanger are tubes (or tube bundle), shell, front end head, rear-end head, baffles, and tube sheets, A variety of different internal constructions

are used in shell-and-tube exchangers, depending on the desired heat transfer and pressure drop performance and the methods employed to reduce thermal stresses, to prevent leakages, to provide for ease of cleaning, to contain operating pressures and temperatures, to control corrosion, to accommodate highly asymmetric flows, and so on.

### 1.2.3.3 Plate type heat exchangers

Plate-type heat exchangers are usually built of thin plates (all prime surfaces). The plates are either smooth or have some form of corrugation, and they are either flat or wound in an exchanger. Generally, these exchangers cannot accommodate very high pressures, temperatures, or pressure and temperature differences. Plate heat exchangers can be classified as gasketed, welded (one or both fluid passages), or brazed, depending on the leak tightness required

### 1.2.4 Depending on the state of the liquid

#### 1.2.4.1 Condenser

If the generator is used to condense the liquid, the condensed liquid will be at a constant temperature over the entire length of the heat exchanger by absorbing the latent heat of condensation released by the condensate. liquid. . This heat exchanger is also called condenser.

#### 1.2.4.2 Evaporator

On the other hand, if a liquid evaporates in the exchanger, the temperature of the liquid in the exchanger will remain the same for a long time, while the temperature of the other liquid will remain low compared to the length of the exchanger and the device is called an evaporator.

### 1.3 Counterflow Heat Exchanger

The function of the heat exchanger is to transfer heat from one fluid to another. The main part of device can be thought of as a tube through which one fluid flows and the other fluid flows out. Three heat transfer processes should be described:

- Convective heat transfer from the fluid to the inner wall
- Convective heat transfer through the tube
- Convective heat transfer from the wall tube to the outer fluid.

The simplest electrical equipment is equipment in which hot and cold fluids move in the same or opposite directions in a concentric tube (or two-tube) structure. In joint flow, hot and cold fluids enter at the same end, flow in the same direction, and exit at the same end. In a counterflow arrangement, fluid enters at the opposite end, flows in the opposite direction, and exits at the opposite end, as shown in Figure 2.

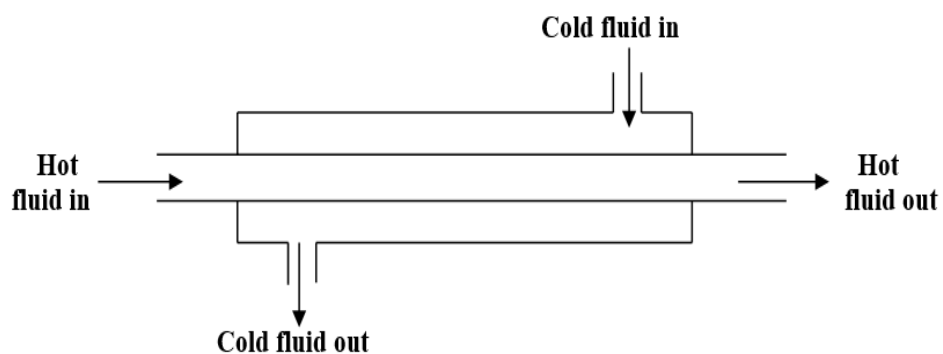

Fig. 2: Counter flow heat exchanger.

### 1.4 HEAT EXCHANGER ANALYSIS

In order to understand heat transfer phenomenon in a heat exchanger, schematic of counter flow heat exchanger is shown in Fig. 3

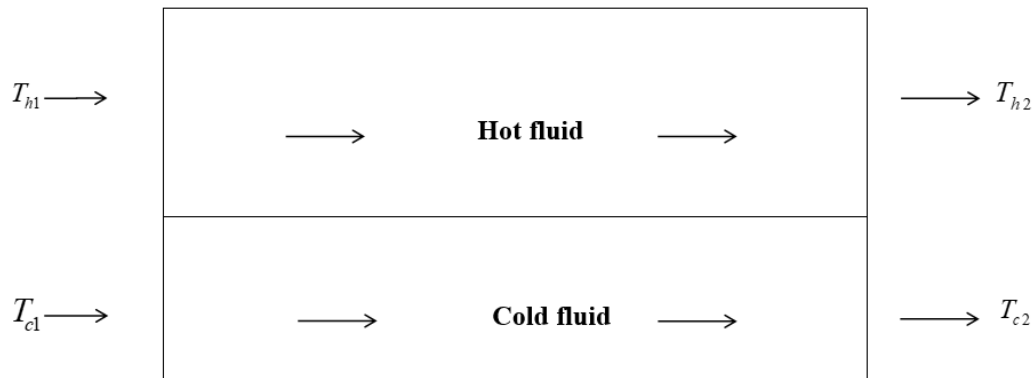

Fig.3: Schematic of conventional heat exchanger.

For analysis of heat exchangers, effectiveness is mainly taken into consideration. Effectiveness of a heat exchanger is defined as the ratio of actual heat transfer to the maximum possible heat transfer. Because of the irreversibility in heat exchanger, the cold fluid does not take up total heat transferred by the hot fluid stream. As a result of this, the effectiveness of heat exchanger based on hot fluid and cold fluid are not equal. In this work, effectiveness is defined based on the hot fluid stream. Assuming that there is no heat loss to the surroundings, heat transfer rate can be calculated by using the following equations:

Effectiveness of the counter flow heat exchanger is given by the equation as

$$\varepsilon = \frac{Q}{Q_{\max}} \quad (1.1)$$

Rate at which heat given by the hot fluid

$$Q = \dot{m}_h c_{ph} (T_{h1} - T_{h2}) \quad (1.2)$$

Rate at which heat taken by the cold fluid

$$Q = \dot{m}_c c_{pc} (T_{c2} - T_{c1}) \quad (1.3)$$

Maximum heat supplied

$$Q_{\max} = c_{\min} (T_{h1} - T_{c1}) \quad (1.4)$$

Counter flow heat exchanger has many industrial applications like milk pasteurization, heat recovery system, crude oil heat treatment etc. Effectiveness of this type of heat exchanger can be increased by the methodology of artificial roughness described by Bhushan and Singh (2009). In the present work, an extensive CFD investigation has been carried out in order to study the performance of counter flow heat exchanger having inner and outer surface of inner pipe of counter flow heat exchanger roughened by SolidWorks tool.

## II. LITERATURE REVIEW

Heat transfer technology is frequently used in heat exchanger systems to improve heat transfer and improve the thermal performance of the system. Improved energy transfer technology is divided into two groups: active methods and passive methods. In the active method, energy transfer is increased by providing additional energy to the fluid or material. Common methods include the use of electronic components, rotating parts, mixing liquids with components, and creating static electricity in the flow field. In contrast, passive means there is no other power. Passive methods include: roughened surface, enlarged surface, coated surface, and turbulator or vortex generator devices as discussed in this section. Diprey and Sabersky (1963) attempted to study the relationship between heat transfer and friction in smooth and rough tubes. Three rough tubes and one smooth tube are made of electroplated nickel. Rough cups have a similar volume from roughness to height for diameters from 0.0024 to 0.049. The heat transfer coefficient and friction coefficient are measured by passing distilled water through an electrical tube Weber et al. (1970) explained that heat and friction exchange occurs for the pressure in the vessel with the reverse rib roughness. The friction dependence is based on the analogous wall law, which is the same method that Nikuradse used to calculate the roughness of sand grains. The thermal relationship is based on the use of the thermal momentum transfer analogy for flow over rough surfaces, originally used by Diprey and Sabersky for sand roughness. The relationship is identified by testing data for  $0.01 < e/D < 0.04$  and  $10 < p/e < 40$ , covering the range  $0.71 < Pr < 37.6$ . Gee (1980) reported a study of single-phase forced convection in a circular tube with two-dimensional rib roughness. It continues the cutting-edge process by examining the effect of rib helix angle. Although previous studies have shown that angles less than  $90^\circ$  will allow heat transfer to the pump, data on flow in blood vessels has not been published. The current study shows the heat and friction variation of air at three angles ( $30^\circ$ ,  $49^\circ$  and  $70^\circ$ ), with a sound/pitch ratio of 15 for all spiral angles. Himanshu et al. (1987) proposed an analytical model to predict heat transfer coefficients and friction coefficients for the surface geometry of offset rod-fin heat exchangers. The two types of flow are laminar flow and turbulent flow. An equation has been developed to predict the transition from laminar to turbulent flow under wake conditions. Perform visualization experiments to identify flow patterns during transitions. This is predicted by the transition equation corresponding to the onset of oscillation velocities in the wing wake. The momentum and energy balance of the unit is written into the crossbar wing geometry and the Nusselt number and

friction coefficient equation is established. The solution was used to calculate  $Nu$  and  $f$  of the blades in the laminar region, while the semi-empirical method was used in the turbulent region. Predictions were compared with data obtained from the scaled-up geometries used in this study, as well as with data obtained from real electronics. The model estimates all data within  $\pm 20$ . Magrakvelidze (1996) presents the results of an experimental study of the mixing process and heat transfer in a stirrer vessel for smooth and rough pipes. Experiments have shown that the effect of roughness on heat transfer occurs in three cases: 1. The case where roughness has no effect on heat transfer; 2. The situation where roughness has no effect on the transmission of electricity. 2. regime of partial influence of roughness on heat transfer; 3. fully developed roughness effect regime. It was established that creation of two-dimensional artificial roughness on the heated surface causes the essential 90% intensification of convective heat transfer in case of fully developed roughness effect regime. Hosni (1998) described the results of previous experiments on six test areas (five rough and one smooth). Three of the rough surfaces are smooth plates with evenly spaced hemispherical points of 2, 4, and 10 base diameters. The remainder of the two rough areas are smooth plates roughened into truncated right cones equal to 2 and 4 base diameters. The roughness geometries of both the hemisphere and the cut region have a base diameter of 1.27 mm and a roughness height of 0.635 mm. Stanton number data are valid for zero pressure gradient incompressible turbulent boundary layer flow with free stream velocity ranging from 6 to 66 m/s, covering aerodynamically smooth transition roughness and all rough flow regimes. Tsia and Hwang (1998) proposed to study heat transfer and friction in a rectangular tube consisting of a series of connecting and separating ribs. Depending on the hydraulic diameter of the pipe, the Reynolds number  $Re$  is between 12,000 and 70,000, and the rib-pressure ratio ( $P_i/h$ ) is between 10 and 30. The ribs for channel height ratio and center-to-height ratio are constant at  $h/2B = 0.2$  and  $c/h = 0.5$  respectively. The results show that the distance between the coupled finned duct is longer than the distance between the fully connected and separated finned duct. Among the three types of ribbed walls, the composite ribbed wall produces the highest construction heat coefficient and average pressure loss. Gunes (2000) attempted to study the electric shock error and the shock characteristics of the development of hydrodynamic turbulence in a horizontal equilateral triangular pipe with the same length and hydraulic diameter with surface roughness of 1.2, 1.2 and 1.2, respectively. Experiments were carried out with Reynolds numbers based on hydraulic diameters between 7,000 and 20,000. All inner walls of the pipe are heated evenly, while the outer part is insulated. It was also determined that pipes with higher roughness would have better heat transfer. Dimensionless expressions have also been developed for determining the transfer coefficient and friction coefficient of equilateral triangular pipes with different surface roughness. Pei-Xue Jiang (2001) presented experimental information for single-phase forced convection in a circular tube containing a two-dimensional rib roughness. It extends the state-of-the-art by examining the effect of the rib helix angle. Although prior studies have proposed that helix angles less than  $90^\circ$  will provide superior heat transfer per unit pumping power, no data have been reported for flow in circular tubes. The present work reports the heat transfer and friction characteristics for air flow with three helix angles ( $30^\circ$ ,  $49^\circ$  and  $70^\circ$ ) all having a rib pitch-to-height ratio of 15. The preferred helix angle is approximately  $45^\circ$ . The data are correlated in a form to permit performance prediction with any relative roughness size ( $e/D$ ). The benefits of the roughness for heat exchanger applications are quantitatively established. The pioneering work of Nikuradse established the sand grain roughness as a major parameter in defining the friction factor during laminar and turbulent flows. Recent studies have indicated a transition to turbulent flows at Reynolds number values much below 2300 during single-phase flow in channels with small hydraulic diameters. In the present work, a detailed experimental study is undertaken to investigate the roughness effects in small diameter tubes. The roughness of the inside tube surface is changed by etching it with an acid solution. Two tubes of 1.032 mm and 0.62 mm inner diameter are treated with acid solutions to provide three different roughness values for each tube. Hosni (1998) described the previous experiment in six test areas (five rough and one smooth). Three of the rough surfaces are smooth plates with equal hemispherical points with base diameters of 2, 4, and 10. The remaining two rough surfaces are a smooth cone-shaped roughened plate with base diameters equal to 2 and 4. The hemisphere and cutting area have a base diameter of 1.27 mm and a roughness height of 0.635 mm. Stanton number data are available for incompressible turbulent boundary layer flow with zero pressure gradient in the freestream velocity range of 6 to 66 m/s, covering aerodynamically smooth transition roughness and all rough flow regimes. Tsia and Hwang (1998) proposed to study heat transfer and friction in a rectangular tube with parallel and discrete lines. Depending on the hydraulic diameter of the pipe, the Reynolds number  $Re$  varies between 12,000 and 70,000 and the pressure ratio ( $P_i/h$ ) is between 10 and 30. The channel height ratio and the average height ratio of the ribs are constant  $h/2B = 0.2$  and  $c/h = 0.5$ , respectively. The results show that the distance between connected tubes is larger than the distance between connected tubes and separated finned tubes. Among the three types of beam walls, composite walls have the highest building thermal coefficient and average pressure drop. Pei-Xue Jiang (2001) presented experimental data on single-phase forced convection in a circular tube with two-dimensional rib roughness. It presents a state-of-the-art technique by examining the effect of rib helix angle. Although previous studies have shown that angles less than  $90^\circ$  will allow heat transfer to the pump, data on flow in blood vessels has not been published. The present study shows the heat transfer and friction characteristics of air flow at three angles ( $30^\circ$ ,  $49^\circ$  and  $70^\circ$ ) and the ridge/height ratio for all angles is 15. The preferred helix angle is about  $45^\circ$ . The data are correlated in a format that allows a good estimate of each relative roughness magnitude ( $e/D$ ). The effect of roughness on energy conversion has been widely evaluated. Satish et al. (2003) described the effect of roughness on shock and heat transfer in circular tubes, which have been extensively studied in the literature. Nikuradse's pioneering work revealed that sand roughness is an important factor in the coefficient of friction during laminar and turbulent flow. Recent studies have shown that during single-phase flow at small hydraulic diameters, there is a transition to turbulent flow at Reynolds numbers well below 2300. Promvong (2008) describes the visualization of air turbulence formation and mass change in a square-section wind tunnel with reverse corrugated rib roughness at the bottom of the wind tunnel direct video recording of flow patterns using simple particle visualization techniques. For the proximity of positively chamfered ribs ( $p/e \leq 5$ ), vortex shedding is observed compared to square or negatively chamfered ribs, which can be seen as a function of the Reynolds number. Duan and Muzychka (2008) describe the effect of corrugated surface roughness on the formation of laminar flow in microtubules. The energy equation was solved using the perturbation method at the slip boundary. A new analytical model was developed to predict the friction coefficient and pressure drop in corrugated rough microtubes for steady flow and shear flow. The proposed model explains the observation that some experimental losses in microchannel flow show a significant increase (15–50%) due to roughness. The shear flow design incorporates the combined effect of high speed and small fluctuation roughness.

### III. PROBLEM FORMULATION

A review of the literature shows that a lot of effort has been devoted to improving the overall power conversion and performance of heat exchangers. In this research work working fluid i.e. water (both cold fluid and hot fluid), operating at different temperatures was examined. Since then, no correlation between the two has ever been seen before in the field of heat exchange. Therefore, it was decided to examine counterflow heat exchangers by using surface roughness and heat transfer in the analysis using the Solid Works flow simulation tool. In short research is based on the evaluation of effectiveness and friction factor for smooth and roughened heat exchanger under the specified range of operating parameters.

### IV. RESEARCH METHODOLOGY

The methodology section outlines the plan and method that how the study is conducted. Computational Fluid Dynamics (CFD) is a method that uses numbers and methods to solve and analyze heat and fluid related problems. High-tech computers are used to perform the extensive calculations required to simulate turbulent conditions and the interaction of the fluid with areas defined by the boundary. In order to carry out present CFD based investigation, model of counter flow heat exchanger was designed based upon following parameters assuming stainless steel as its prime material. Water as hot and cold fluid was used in the heat exchanger. Hot water was passed through the internal pipe and cold water was passed through the external pipe. Roughness on the inner and outer surface of the inner pipe was generated by formation of ring type geometry using stainless steel.

Table 1: Experimental study parameters

Particular	Dimension
Inner length of test section, L	1.5 m
Length of test section, L	1.6 m
Inner diameter of hot water pipe, D	17 mm
Inner Diameter of pipe	21 mm
Outer diameter of pipe	42 mm
Height of ring	0.5 - 2 mm
Pitch of ring	10-50 mm
Mass flow rate of water, $\dot{m}$	0.016 kg/s
Specific heat of water, $c$	4178 J/kg K
Density of water, $\rho$	997.56 kg/m <sup>3</sup>
Average velocity of water, $V$	0.073 m/s
Dynamic viscosity of water, $\mu$	0.0378x10 <sup>-5</sup> kg/ms
Temperature of hot water at inlet, $T_{hi}$	75 °C
Temperature of hot water at outlet, $T_{ho}$	52.95 °C
Temperature of cold water at inlet, $T_{ci}$	25 °C
Temperature of cold water at outlet, $T_{co}$	45.8 °C
Pressure Drop in test section, ( $\Delta p$ )	782.5 N/m <sup>2</sup>

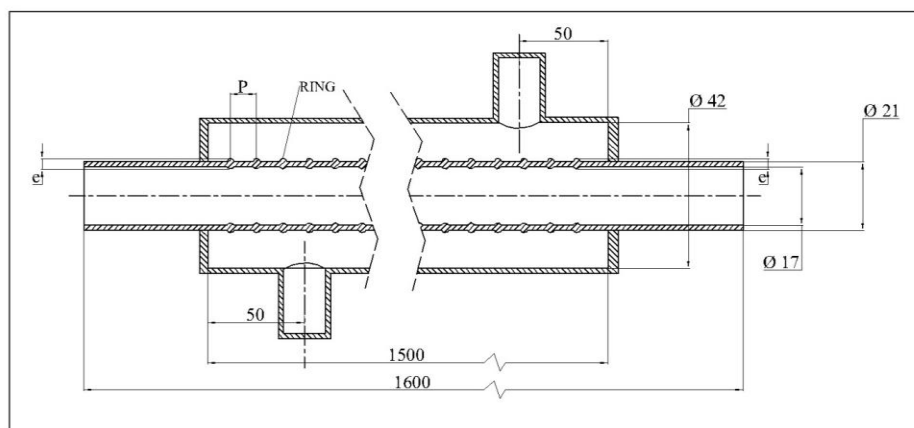

Fig. 4. Schematic of counter flow heat exchanger.

#### 4.1 Operating parameters for CFD model generation

CFD has now been carried out to study the effect of system and operating parameters on the operation of smooth and coarse counter flow heat exchangers

Table 2: CFD model generation operating parameters.

S. No.	Operating Parameter	Range /Value
1.	Reynolds number (Re)	3000 – 20000
2.	Relative roughness pitch (p/D)	0.588 – 2.94
3.	Relative roughness height (e/D)	0.029 – 0.117
4.	Mass flow rate of hot water ( $\dot{m}_h$ ) and cold water ( $\dot{m}_c$ )	0.016 – 0.1 kg/s
5.	Roughness height (e)	0.5 – 2 mm
6.	Temperature of hot water at inlet of inner pipe ( $T_{hi}$ )	75 °C
7.	Temperature of cold water at inlet of outer pipe ( $T_{ci}$ )	25 °C
8.	Mass flow rate	0.016- 0.1 kg/s.

#### 4.2 Solid Work Model generation from CFD Data.

Based upon the selected dimensions, model of counter flow heat exchanger shown in Fig. 4.2 was constructed with the help of SolidWorks software (version 2010).

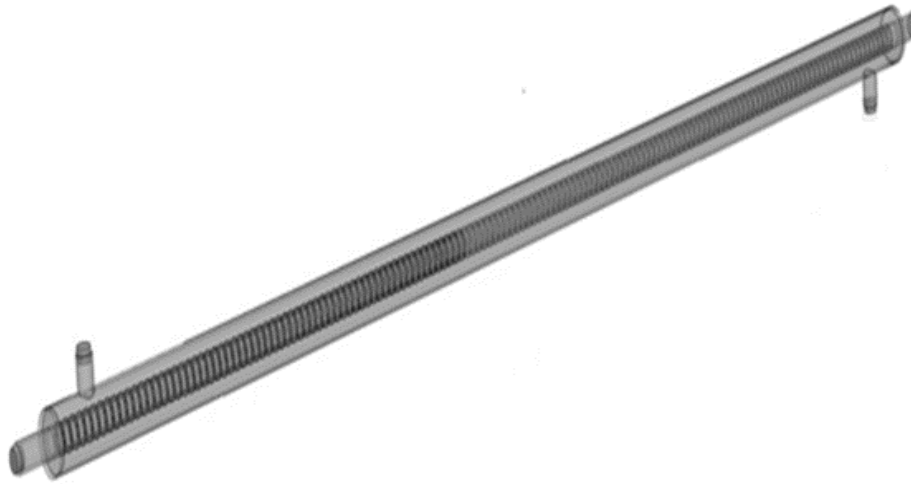

Fig 5 CFD model of counter flow heat exchanger.

The actual heat transfer is calculated as heat energy lost by the hot fluid or the heat energy gained by the cold fluid.

#### 4.3 Procedures for conducting CFD-based research

All components and targets of the electronic equipment were carefully checked before starting the analysis. This experiment was conducted to collect useful information and disagreements in ordinary situations. Six flow parameters were used for all CFD studies. 2D analysis is based on the following assumptions; water is stable, strong and powerful. Thermal conductivity of different materials and rough materials does not change with temperature. Heat exchanger and roughness element is homogenous and isotropic. Non uniform meshing was generated over the heat exchanger and finer meshing was done on the roughness element because accuracy and computation time depends upon the type of mesh generation. Finer meshing generates accurate results at increased computation time. In each set of CFD based investigation, duct model was modified as per combination of parameters of roughness geometry. Before starting the investigation, heat exchanger inlet and outlet were closed with lids because boundary conditions at inlet and exit were defined on lid surface in contact with water in order to evaluate the required goals. Temperature and size are considered limits for shock to be seen in the testing of electrical equipment. Adjust the surface and balance target of the heat exchanger model so that the data is written in the desired form. Finally run the test and get the results based on the calculation time. All sets of results are received in the form of MS Excel worksheets and various plans. It is easy to obtain voltage, temperature and pressure drop from CFD data. These data are used to determine the Reynolds number, efficiency, shock through the test section and coefficient of friction, which are described in the following sections:

#### 4.4 Calculations and Formulae used

##### 4.4.1 Heat transfer rate (Q):

Cold heat transfer. flow value in the outer pipe The volume of water is calculated according to the following formula:

$$Q = \dot{m}_c c_{pc} (T_{c2} - T_{c1}) \quad (4.1)$$

##### 4.4.2 Reynolds number (Re):

Reynolds number (Re) is used to specify the function in dimensionless form. It is used to determine laminar, variable or turbulent water flow. Therefore, it is considered a poor performance in current CFD research and is analyzed using the following correlations:

$$Re = \frac{\rho VD}{\mu} \quad (4.2)$$

#### 4.4.3 Effectiveness ( $\epsilon$ ):

Effectiveness was evaluated by using the following relationship;

$$\epsilon = \frac{Q_{actual}}{Q_{max}} = \frac{\dot{m}_h c_{ph} (T_{h1} - T_{h2})}{\dot{m}_h c_{pc} (T_{h1} - T_{c1})} \quad (4.3)$$

#### 4.4.4 Friction Factor ( $f$ ):

Friction factor was evaluated by using the following relationship;

$$f = \frac{2\Delta PD}{4\rho LV^2} \quad (4.4)$$

## V. RESULTS AND DISCUSSION

Results of the experiment are tabulated depicting the variations of mass flow rate and Reynold number with roughness of pipes

### 5.1 Tables

Table3:Table showing variation of mass flow rate with effectiveness( in percentage ) with variable p/D ratio

Mass flow rate(m)	Effectiveness(%age)			
	smooth tube	p/D=0.588	p/D=0.0882	p/D=2.941
0.016	15	49	45	42
0.033	12	47	41	39
0.05	10	45	38	36
0.066	8	43	35	33
0.0833	6	39	33	30
0.1	4	37	30	27

Table 4:Table showing variation of mass flow rate with effectiveness( in percentage ) with variable e/D ratio

Mass flow rate	Effectiveness(%age)				
	smooth tube	e/D=0.0294	e/D=0.0588	e/D=0.0882	e/D=0.117
0.016	15	37	42	45	49
0.033	12	34	39	41	47
0.05	10	31	36	38	45
0.066	8	28	33	35	43
0.0833	6	25	30	33	39
0.1	4	23	27	30	37

Table5:Table showing variation of Reynold Number with effectiveness( in percentage ) with variable p/D ratio

Reynold Number	Effectiveness(%age)			
	smooth tube	p/D=0.588	p/D=1.764	p/D=2.941
3273.2	15	45	42	37
6501.2	12	41	39	34
9901.3	10	38	36	31
13048.3	8	35	33	28
16517.8	6	33	30	25



19718.9	4	30	27	23
---------	---	----	----	----

Table6:Table showing variation of Reynold Number with effectiveness( in percentage ) with variable e/D ratio

Reynold Number	Effectiveness(%age)				
	smooth tube	e/D=0.0294	e/D=0.0588	e/D=0.0882	e/D=0.117
3273.2	15	37	42	45	49
6501.2	12	34	39	41	47
9901.3	10	31	36	38	45
13048.3	8	28	33	35	43
16517.8	6	25	30	33	39
19718.9	4	23	27	30	37

Table7:Table showing variation of Reynold Number with effectiveness( in percentage ) with variable p/D ratio

Reynold Number	Effectiveness (%age)					
	Smooth tube	p/D=2.941	p/D=2.352	p/D=1.764	p/D=1.7642	p/D=0.588
3273.2	15	37	40	44	47	49
6501.2	12	34	37	40	45	47
9901.3	10	30	35	37	43	44
13048.3	8	27	32	35	39	43
16517.8	6	25	29	32	36	38
19718.9	4	22	27	29	33	37

Table 8:Table showing variation of p/D ratio with effectiveness( in percentage ) for the fixed values of Reynold Number

p/D	Effectiveness(%age)					
	Re=3273.2	Re=6501.2	Re=9901.3	Re=13048.3	Re=16517.8	Re=19784.10
0.588	49	47	45	43	40	37
1.176	42	40	37	35	32	29
1.764	40	39	36	34	31	28
2.352	39	37	35	32	29	27
2.941	37	34	30	27	25	22

Table 9:Table showing variation of e/D ratio with effectiveness( in percentage ) for the fixed values of Reynold Number

e/D	Effectiveness(%age)					
	Re=3273.2	Re=6501.2	Re=9901.3	Re=13048.3	Re=16517.8	Re=19718.9
0.0294	37	34	31	28	25	23
0.0588	42	39	36	33	30	27
0.0882	45	41	38	35	33	30
0.117	49	47	45	43	39	37

## 5.2 Graphs

Following graphs have been plotted from readings shown in figure 6 and figure 7.

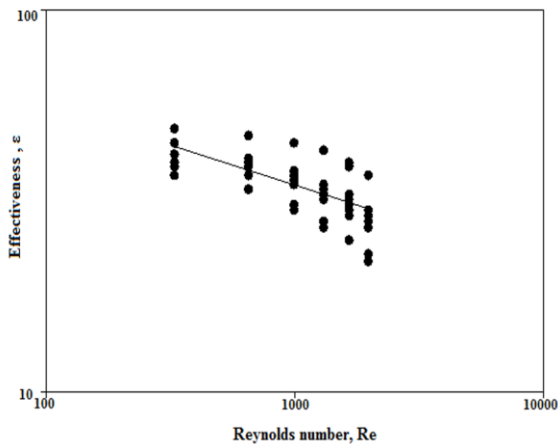

Figure 6 Plot of effectiveness v/s Reynold Number

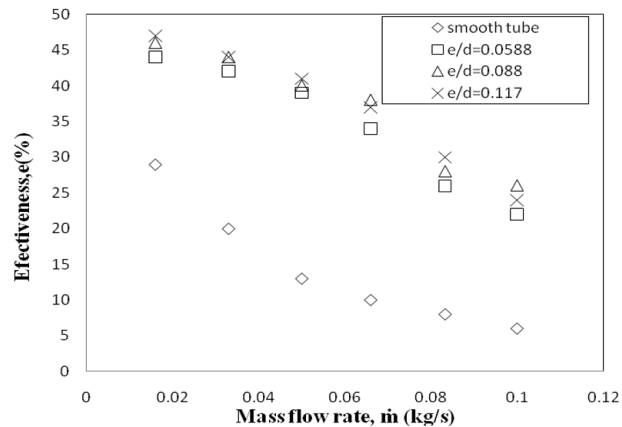

Figure 7 Plot of effectiveness v/s Mass flow rate

These values were found to be good agreement with CFD simulation data

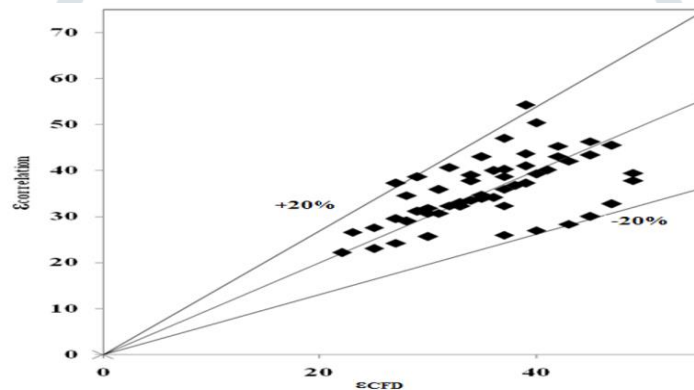

Figure 8 Comparison of tabulated values with CFD simulation values

## VI. CONCLUSION

In this research work, effectiveness of heat exchanger was evaluated by variation of roughness on pipes using the CFD data. From the tabulated values obtained through CFD analysis, it can be concluded that

1. Effectiveness of counter flow heat exchanger decreases monotonously with increase in Reynolds number for smooth and roughened inner pipe.
2. Effectiveness of counter flow heat exchanger increases with increase in relative roughness height ( $e/D$ ) and decrease in relative roughness pitch ( $p/D$ ) at each value of Reynolds number.
3. Effectiveness of roughened inner pipe is considerably higher than smooth inner pipe of counter flow heat exchanger.
4. Comparison of CFD data and data predicted from the developed effectiveness and friction factor correlations shows good agreement.
5. The above finding also indicates that ring type roughness geometry in counter flow type of heat exchanger enhances heat transfer with considerable pressure drop.
6. The ring type roughness geometry enhances the effectiveness of roughened inner pipe by 35% as compared to smooth inner pipe.

## VII. FUTURE SCOPE

It has been conceded from the outcome of the present research work that one can extend this work for carrying out further investigation as given below:

1. Effectiveness and friction factor correlations can be used to develop mathematical model for carrying out investigation on experimental performance of artificially roughened counter flow heat exchanger.
2. CFD investigation can be carried out on new types of roughness geometries under all categories of artificial roughness geometries reported in literature.

### VIII. ACKNOWLEDGMENT

I would like to convey my thanks and acknowledgement to Dr Ranjit Singh, Associate Professor and Head Mechanical Engineering Department, Beant College of Engineering and Technology, Gurdaspur, Punjab for permitting me to carry out research work and providing me requisite guidance and logistics in timely completion of research work.

### REFERENCES

- [1] Alper Ozalp A. (2009), "1st and 2nd Law Characteristics in a Micropipe: Integrated Effects of Surface Roughness, Heat Flux and Reynolds Number". *Heat Transfer Engineering*, vol. 30, pp. 973-987.
- [2] Dipprey D.F., and Sabersky R.H. (1963), "Heat and momentum Transfer in Smooth and Rough Tubes at Various Pr Numbers". *International Journal Heat and Mass Transfer*, vol.6, pp. 329-353.
- [3] Gunes S., Ozceyhan V., Buyukalaca O. (2010), "Heat transfer enhancement in a tube with equilateral triangle cross sectioned coiled wire inserts". vol. 34, pp. 684–691.
- [4] Gee, D.L., Webb, R.L. (1980), "Forced convection of heat transfer in helically rib-roughened tubes". Elsevier science Ltd, vol. 32, pp. 1127–1136.
- [5] Gunes, S., Ozceyhan, V., Buyukalaca, O. (2010), "Heat transfer enhancement in a tube with equilateral triangle cross sectioned coiled wire inserts". *Experimental Thermal and Fluid Science*, pp. 684-691.
- [6] Hans, V.S., Saini, R.P., Saini, J.S., "Heat transfer and friction factor correlations for a solar air heater duct roughened artificially with multiple v-ribs". Elsevier science Ltd, vol. 13, pp. 898–911.
- [7] John Matsson (2010), "Introduction to SolidWorks flow simulation", SDC publications.
- [8] Kumar S., Saini, R.P., (2009), "CFD based performance analysis of a solar air heater duct provided with artificial roughness". Elsevier science Ltd, vol. 34, pp. 1285–1291.
- [9] Magrakvelidze T., Bantsadze N.Lekveishvili N. (1996), "Influence of Artificial Roughness on Heat Transfer to Turbulent Mixed Liquid in a Pool", *Bulletin of the Georgian Academy of Sciences*, pp. 397-400.
- [10] Ozalp Alper A. (2009), "1st and 2nd law characteristics in a Micropipe: Integrated effects of surface roughness". *Heat Flux and Reynolds Number*.
- [11] Promvong P. (2008), "Thermal performance in circular tube fitted with coiled square wires". *Energy Convers Manage*, pp. 980–987.
- [12] Pie-Xue J., Ming-Hong F.,Guang-Shu S.,Zei-Pei R. (2001), "Thermal-hydraulic performance of small scale micro-channel and porous-media heat exchangers". vol. 44, pp. 1039-1051.
- [13] Rajput R.K. (2007), "Heat and Mass Transfer", S. Chand and Company ltd., 6<sup>th</sup> edition.
- [14] Sahin B., Demir A. (2008), "Thermal performance analysis and optimum design parameters of heat exchanger having perforated pin fins", vol. 49, pp. 1684-1695.
- [15] Sahin. B., (2004), "Investigation of heat and flow characteristics for heat exchangers having contracted oriented rectangular fins", Ph.D. Thesis (in Turkish), Ataturk University.
- [16] Tsia J.P., Hwang J.J. (1998), "Measurements of heat transfer and fluid flow in a rectangular duct with alternate attached–detached rib-arrays", Elsevier science Ltd., vol. 42, pp. 2071-2083.
- [17] Webb, Eckert, Goldstein R.J. (1971), "Heat transfer and friction in tubes with repeated-rib roughness", Elsevier science Ltd., vol. 14, pp. 601- 617..
- [18] Yunus, A.C., Michael, A.B. (2001), "Thermodynamics an Engineering Approach", 5<sup>th</sup> edition.