

Design and Development of Agriculture Reaper

Arvind Dhobale¹, Sagar Bhor², Sangram Bhor³, Ganesh Gopale⁴, Kiran Hande⁵

¹Assistant Professor, Department of Mechanical Engineering, JCOE Kuran, Maharashtra, India.

^{2,3,4,5}U.G. Student, Department of Mechanical Engineering, JCOE Kuran, Maharashtra, India

Abstract- The main domain of agriculture or farming in India is not only limited to growing of crops but is also associated with the financial growth of farmers and labours. Small area farmers frequently face the problem of labour shortage or are unable to afford the costly equipment. It is therefore, easy to buy the mechanical methods so that the timeliness in farming operation could be ensured. Considering different factors as power source, cost of object, mode of operation, site condition, time of operation and weather conditions. It runs on four stroke petrol engine, this power from engine, is provided through pulley and gear box arrangement to the cutter. This compact harvester is manufactured using locally available spare parts and thus, it has low maintenance. This reaper might be the solution to the problems faced by a small scale farmer regarding cost and labour implementation.

I. INTRODUCTION

Agriculture is the main income side of India. In India agriculture has facing serious challenges like scarcity of agricultural labour, in peak working seasons but also in normal time. This is mainly for increased nonfarm job opportunities having higher wage, migration of labour force to cities and low status of agricultural labours in the society. In India two type of crop cutting like as manual method (conventional method) and mechanized type of crop cutter. The crop cutting is important stage in agriculture field. Currently Indian farmer used conventional method for crop cutting i.e. cutting crop manually using labour but this method is very lengthy and time consuming. To design and analysis the crop cutter machine which is help to the Indian farmer which is in rural side and small farm. It will reduce the cost of crop cutting in field. It will help to increase economical standard in Indian farmer. The design of the crop cutting machine

will be presented by using CREO drawing software. The force analysis on the cutter blade. The force analysis on the roller cutter blade by using ANSYS 16.0 software. This rendered the cutter safe from the cutting forces.

Mechanized agriculture is the process of using agricultural machinery to mechanize the work of agriculture, greatly increasing farm worker productivity. In modern times, powered machinery has replaced many jobs formerly carried out by manual labour or by working animals such as oxen, horses and mules. The history of agriculture contains many examples of tool use, such as the plough. Mechanization involves the use of an intermediate device between the power source and the work. This intermediate device usually transforms motion, such as rotary to linear, or provides some sort of mechanical advantage, such as speed increase or decrease or leverage. Current mechanized agriculture includes the use of tractors, trucks, combine harvesters, airplanes (crop dusters), helicopters, and other vehicles. Modern farms even sometimes use computers in conjunction with satellite imagery and GPS guidance to increase yields.

Reapers are used for harvesting of crops mostly at ground level. Reapers are classified on the basis of conveying of crops. It avoids fuel consumption, labour requirement. As the population of India increases day by day, there is increment of food, vegetables so need of farm mechanization also increases, machineries provides more operations in less time, but the machineries are very costly for the common man, it is not affordable for them, so manually

operated machineries, equipment's are also the most important factor. Reaper harvesters on the other hand are other alternative harvesting equipment, provided straw is considered as economic by-product for animal feed and/or industrial applications.

A. PROBLEM STATEMENT

Manual operation of cutting takes time and is not effective as they can work more than 3-4 hours. Even if the land is small, it takes two or three days to complete work operation of the crop. High costs of machines and maintenance, non-availability of appropriate agricultural machines and equipment that cater to and suit the requirements of small scale farms. In manual method crop are cut by manual It takes time and it is not effective as they can work only 5-6 hours in a day. Even though the small scale farmers who having land less than 5 acres, it takes two to three days to cut.

B. OBJECTIVES

1. Design should be 'Simple' to operate and 'Safe'.
2. It should have 'Low Cost of Maintenance'.
3. It should require Less Man Power.
4. The design should be Robust and Reliable.
5. To modify the manually operated Reaper.
6. To evaluate the performance of modified manually operated Reaper.

II. LITERATURE REVIEW

The purpose of the literature review is to go through design, analysis and experimental testing of agriculture reaper. Reaper is the machine where can we cut the crops more than 2feet in height. Now a days manmade crop cutting method is use for cutting the crop .but its is time consumable and need more efforts. Due to lack of problems of labour availability in india for farming need to find a solution on it. So we can design a reaper for small scale farmers from the previous research we can find and analysis

of the available design of reaper.

A. SCOPE

1. By replacing the motor we can use wheel operated cutter rotation by using the sprocket, chain
2. This machine can also be used for cutting other crops such as cotton stalks and maize.
3. As the field is uneven, the cutter height varies from mode to node, so a slider mechanism can be used to vary the height of cutter from time to time.

III. METHODOLOGY

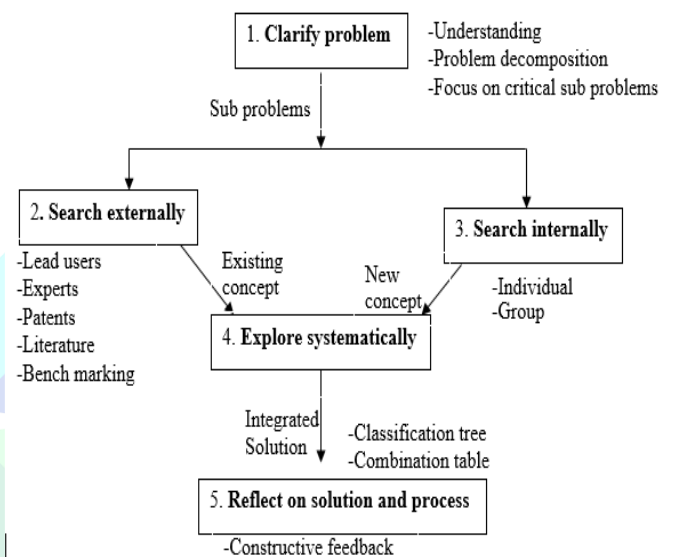

IV. DESIGN CALCULATION

1. Selection of Engine.

For selection of engine, engine power is to be determined. We have taken following parameters for design purpose:

Diameter of stalk = 30mm

$$\text{Area} = (\pi/4) * (30)^2 = 706.85 \text{ mm}^2$$

$$\text{Shear strength} = 3 \text{ N/mm}^2$$

Force required for cutting 1 stalk =

$$\text{Shear stress} \times \text{Shear Area} = 3 \times 706.85 = 2121 \text{ N}$$

$$\text{For cutting two stalks, Force required} = 4242 \text{ N}$$

Stroke of cutting = 70 mm

But, stroke = 2 x radius

$$\text{Radius} = 70/2 = 35 \text{ mm} = 0.035 \text{ m}$$

$$\text{Torque} = \text{Force} \times \text{Radius} = 148.47 \text{ Nm}$$

$$\text{Cutter velocity (v)} = 0.5 \text{ m/sec}$$

$$V = \omega * r \quad 0.5 = \omega \times 0.035$$

$$\omega = 14.28 \text{ rad/sec}$$

$$\omega = 2\pi N / 60 \quad N = 140 \text{ RPM}$$

$$\text{Power} = 2\pi NT / 60 = 2.84 = 3 \text{ hp}$$

the shaft.
 Bearing reactions $R_B = -4002.3 \text{ N}$ (downward)
 $R_D = 10102.36 \text{ N}$
 Maximum bending moment occurs at c,
 $M_c = 753820 \text{ Nmm}$

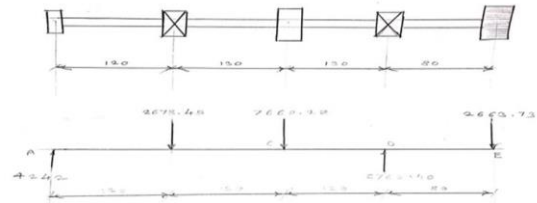

2. Selection of Belt Drive.

Now engine RPM = $N_1 = 3000 \text{ RPM}$
 Output of belt drive required = $N_2 = 720 \text{ RPM}$
 Diameter of input pulley = $D_1 = 2.5''$
 Diameter of output pulley = $D_2 = 10''$
 Selection of belts

Power to be transmitted = 2.2 KW

- 1) Service factor = $F_a = 1.2$
- 2) Design power = $F_a \times \text{Power to be transmitted} = 1.2 \times 2.2 = 2.64 \text{ KW}$
- 3) Section of belt : A Section
- 4) Pitch length of belt : Center distance = $2x$
 $D_2 = 2 \times 10'' = 20'' \quad L = 2C + \pi(D+d)/2 + (D-d)^2/4C = 60.33''$
- 5) Preferred pitch length = $60''$
- 6) Correct center distance: $L = 2C + \pi(D+d)/2 + (D-d)^2/4C \quad C = 19.828''$
- 7) Correction factor for belt pitch length = $F_c = 0.94$
- 8) Correction factor for arc of contact = F_d
 $\alpha_s = 180 - 2\sin^{-1}(D-d)/2C \quad \alpha_s = 158.20$
- 9) Power rating of single V-belt:
 $P_r = 1.46 + 0.36 = 1.82$
- 10) Number of belts required = $P * F_A / (P_r * F_C * F_D) = 1.62 = 2$

$$\tau_{\max} = 75 \text{ N/mm}^2$$

$$\tau_{\max} = (16/\pi d^3) \times ((K_b M_b)^2 + (K_t M_t)^2)^{1/2}$$

$$75 = (16/\pi d^3) \times ((753820 \times 2)^2 + (142.47 \times 103 \times 1.5)^2)^{1/2}$$

$$d = 48.65 = 50 \text{ mm}$$

5. Cutting Blade.

Thickness Of Blade is 4.2 mm
 Inclined cutting Surface is 50 mm
 Shear Area of Blade = $50 \text{ mm} \times 4.2 \text{ mm}$
 $= 210 \text{ mm}^2$
 Shear Stress (Mild Steel) = 240 N/mm^2

So,
 Force Of Cutting Blade = Shear stress x Shear Area
 $= 240 \times 210$
 $= 50400 \text{ N}$
 Required Force is $2121 \text{ N} < \text{Force Of Cutting Blade } 50400 \text{ N}$
 Hence The Design is safe for Cutting Blade.

3. Forces On Worm Wheel.

For worm and worm wheel
 $Z_1 = \text{Number of starts on the worm} = 3$
 $Z_2 = \text{Number of teeth on the worm wheel} = 15$
 $q = \text{Diametral quotient} = 10m = \text{module} = 10 \text{ mm}$
 $d_1 = \text{diameter of worm wheel}$
 $d_1 = q \times m = 10 \times 10$
 $d_1 = 100 \text{ mm}$
 $d_2 = \text{diameter of worm } d_2 = Z_2 * m = 15 \times 10$
 $d_2 = 150 \text{ mm}$
 $(P_1)_t = 2849.4 \text{ N}$
 $(P_1)_r = 2664 \text{ N}$
 $(P_1)_a = 6790 \text{ N}$

4. Main Shaft Design.

Let P_1 and P_2 be the tension and tight and slack side respectively.
 $P_1 = 2414 \text{ N} \quad P_2 = 5264.14 \text{ N}$
 Material of shaft = 45 C8
 $S_{ut} = 650 \text{ N/mm}^2 \quad S_{yt} = 450 \text{ N/mm}^2 \quad \text{F.O.S.} = 3$
 Bearings are mounted at B and D to support



Fig. Actual cutter blade

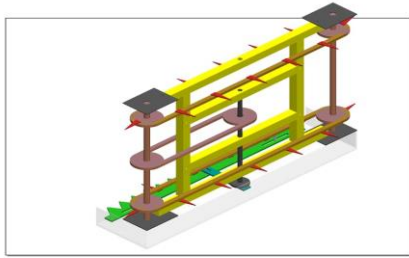

Fig.3d model of cutter mechanism

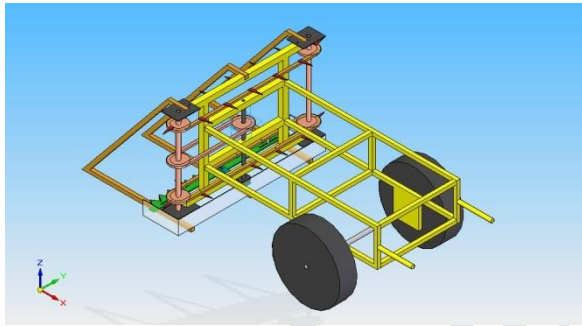

Fig.3d model of assembly of reaper.

ACKNOWLEDGMENT.

We take this opportunity to thank all those who have contributed in successful completion of this Project Stage-I, also We would like to express my sincere thanks to my guide Prof. DHOBALE A.L. who has encouraged me to work on this topic and valuable guidance wherever required. We wish to express my thanks to, DR. D. J. Garkal, Principal, JCOE, Kuran, Prof. MANKAR R.L.HO.D. Mechanical Engineering Department JCOE, Kuran and Project Co-coordinator Prof. NANGARE G. R. for their support and help extended. Finally, We are thankful to all those who extended their help directly or indirectly in preparation of this report.

REFERENCES.

- 1) Imrul Kaes Mirza Kiran, Md. Abdul Awal, Md. Rostom Ali, Development and performance evaluation of a battery operated small-scale reaper, Vol. 19, No. 2 217, August, 2017.
- 2) Amar B. Mule, Pravin T. Sawarkar, Akshay A. Chichghare ,Akash N. Bhiwapurkar , Dhananjay D. Sirsikar ,Kapil R. Gaurkar,Design And Fabrication Of Harvesting Machine, International Research Journal Of Engineering And Technology (IRJET), Volume: 05 Issue: 01 | Jan-2018.

- 3) Aravind C., Shivashankar V., Vikas R., Vikas V., “ Design & Development of Mini Paddy Harvester”, International Journal for Scientific Research & Development, Vol. 3, Issue 05, 2015 | ISSN (online): 2321-0613.
- 4) Laukik P. Raut, Vishal Dhandare, Pratik Jain, Vinit Ghike, Vineet Mishra, “Design, Development and Fabrication of a Compact Harvester”, International Journal for Scientific Research & Development| Vol. 2, Issue 10, 2014 | ISSN (online): 2321-0613.
- 5) State of Indian Agriculture 2012-13, Indian Government Analysis.2. “Design and Development of manually Operated Reaper” Mr. P. B. Chavan, Mr. D. K. Patil, Mr. D. S. Dhondg.(IOSR-JMCE) Journal of Mechanical and Civil Engineering-ISSN:2278-1684,p-ISSN: 2320-334X, Volume 12, Issue 3 Ver. I (May. - Jun. 2015), PP 15-22.