

# Investigation of Tribological Behavior of Peek Composite with Glass Fiber

Kharat Amol<sup>1</sup>, Talekar Sanket<sup>2</sup>, Jadhav Sumit<sup>3</sup>, More Suresh<sup>4</sup>, Shelke Ram<sup>5</sup>

<sup>1</sup>Assistant Professor, Department of Mechanical Engineering, JCOE Kuran, Maharashtra, India.

<sup>2,3,4,5</sup> U.G. Student, Department of Mechanical Engineering, JCOE Kuran, Maharashtra, India.

**Abstract-** The polymer matrix composites are widely used in various mechanical applications. Aim of this project is to study of the Wear, Coefficient of Friction & Frictional Force Polyether-Ether-Keton (PEEK) matrix composites with Glass Fibers (GF). Also, under dry Friction conditions the Wear, Coefficient of Friction & Frictional Force of PEEK matrix composites was studied at temperatures 50°C, 100°C & 150°C. Pure PEEK is having low Friction Coefficient and high Wear rate, so its applications are limited. At room temperature the Friction and Wear of PEEK can be improved by adding different fillers such as Glass Fiber, Carbon Fiber and Metallic Fibers etc. It is found that PEEK with 30 percent by weight GF at 150°C have good Wear resistance. Also at 80 N load under dry condition Wear performance of PEEK with 30 percent by weight GF was improved.

## 1. INTRODUCTION

Composite materials are engineering materials made from two or more constituent materials that remain separate and distinct on a macroscopic level while forming a single component. There are two categories of constituent materials: matrix and reinforcement. The matrix material surrounds and supports the reinforcement materials by maintaining their relative positions. The reinforcements impart their special mechanical environmental damage whereas the presence of fibers/particles in a composite improves its mechanical properties such as strength, stiffness etc. The objective is to take advantage of the superior properties of both materials without compromising on the weakness of either. As defined by V. D. Kodgire [22] composite means material having two or more distinct constituent materials or phases. It is only when the constituent phases have significantly different physical properties and thus the composite properties

are noticeably different from the constituent properties. [22]

Polyetheretherketone (PEEK) is a semi-crystalline color less organic polymer. It is a thermoplastic that has desirably very good mechanical and chemical resistance properties that are retained up to high temperatures. It is highly resistant to thermal degradation as well as attack by both organic and aqueous environments. It has superior resistance to wear and dynamic fatigue. PEEK is a high performance polymer with amazing strengths and heat resistant properties. PEEK polymer is a very rigid plastic with excellent lubricity. PEEK is naturally tan in color; however it can be pigmented with a wide range of colors for part identification. Thin wall PEEK is more flexible and can be cut to length with a razor blade. PEEK is a polymer which is semi-crystalline and is widely regarded as the highest performance thermoplastic material. PEEK have repeating monomer of two ether and ketone groups.

## 2. LITERATURE REVIEW

“Investigation and Development of Tribological Behavior of PEEK and PEEK Composites” Present work describes the development and characterization of a new class of hybrid polymer composites consisting of Polyether-ether-keton (PEEK), polytetrafluoroethylene (PTFE), Bronze and MoS<sub>2</sub>. The effects of various contact temperatures on the tribological properties of PTFE/PEEK composites were studied under dry as well as wet friction conditions. Moreover, the influence of various pressures on the friction and wear behaviors of the PTFE/PEEK composites was investigated. PEEK is a semi-crystalline polymer used as special engineering plastic due to its excellent mechanical capacity, good chemical and thermal stability. PEEK composites are often used as compressor piston rings or valve slices

for their outstanding mechanical and thermal performance at high temperature conditions, where PTFE composites may fail to service. However, high friction coefficient and wear rate of pure PEEK limit its wider use many researchers found that PEEK is good in mechanical characteristic but less good performances of tribological properties. However PTFE shows better performances of tribological properties. The effect on the friction and wear behaviors of PEEK polymer composites has been improved, with addition of PTFE at room temperature. There are various operation performed in industry by different machine parts such as high pressure compressor, bearings, impeller etc. which causes wear due to heavy loading conditions and at ambient temperature. The objective of this work is to study the friction and wear properties of PEEK filled with different filler material at heavy loading conditions and at ambient temperature to enhance tribological behavior of PEEK without loss of mechanical properties.<sup>[1]</sup>

**Gaps from Literature**

- 1 Generally, maximum work had been done on peek at room temperature. Very little work has been done on peek at elevated temperature.
- 2 Literature does not clarify the selection & combination process, blending processing temperature of peek.
- 3 Proper peek processing and developing methods still in the dormant level as far as wear rate, wear resistance and coefficient of friction is concerned.

**3. METHODOLOGY**

- Introduction to Composite
- Literature survey and gaps identified
- Problem definition for improving properties of Composite
- Selection of PEEK and Filler material is Glass Fiber
- To manufacture the Material PEEK Unfilled,70% PEEK+30% GF
- Micro Compounder, Twin Extruder, Compression Molding
- Preparation of experimental setup

- Finalization of testing parameters
- Experimentation on PEEK & PEEK with 30% GF
- With same boundary condition actual working parameter
- Results and Discussion.
- Conclusion

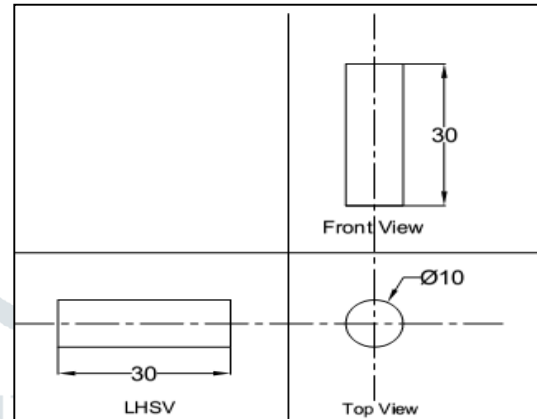

**Fig. 1.1 Specimen Pin Drawing for Wear Testing Ø 10 × 30 mm**

**Table 1.1 Description of Specimen Pin**

Material For Pin	1) PEEK 2) PEEK wit 30% Glass Fibre
Pin Size	Ø 10 mm × 30 mm length ±0.005
Hardness	Shore D 87

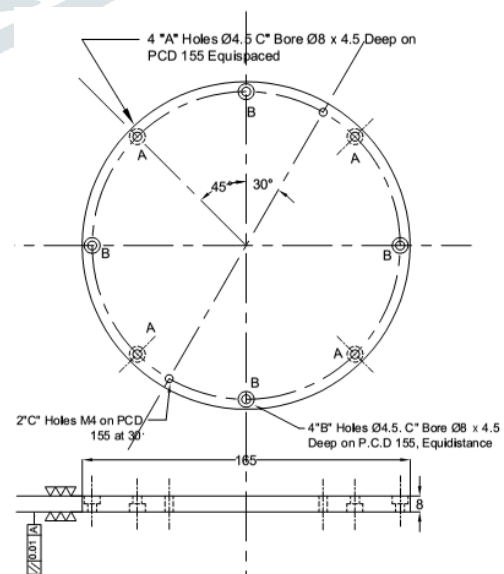

**Fig. 3.5 Steel EN8 disc drawing with size Ø 165 × 8 mm**

## MATERIALS AND METHODS

This chapter describes the details of processing of the composites and the experimental procedures followed for their characterization and tribological evaluation. The raw materials used in this work are Unfilled PEEK and PEEK with 30% GF. Commercially available Polyether ether ketone (PEEK) of grade 450G fine powder with the average diameter of 100  $\mu\text{m}$  was supplied by Victrex. The composite is prepared by injection molding. PEEK with 30% glass fiber are mixed for various batches with batch size 100 gm for injection molding as in Vinit Performance Polymers PVT. LTD Vile Parle (E), Mumbai -400057

Table 1.2 Designation of Composites

Specimen	Compositions
S1	PEEK (100% wt)
S2	PEEK (70% wt) +30% GF

## REFERENCE

1. McEvoy, M. A.; Correll, N. (2015). "[Materials that couple sensing, actuation, computation, and communication](#)". *Science*. **347**(6228). doi:10.1126/science.1261689. Archived from the original on 2015-03-23.
2. [Jump up](#) "Autonomous Materials Will Let Future Robots Change Color And Shift Shape". *popsci.com*. Archived from the original on 27 September 2017. Retrieved 3 May 2018.
3. [Jump up](#) Shaffer, Gary D. (Spring 1993). "An Archaeomagnetic Study of a Wattle and Daub Building Collapse". *Journal of Field Archaeology*. **20** (1): 59–75. *JSTOR* 530354.
4. [Jump up](#) "Minerals commodity summary – cement – 2007". *US United States Geological Survey*. 1 June 2007. Archived from the original on 13 December 2007. Retrieved 16 January 2008.
5. [Jump up to:<sup>a</sup> <sup>b</sup>](#) "History of Composite Materials". *Mar-Bal Incorporated*. Archived from the original on 2018-01-04. Retrieved 2018-01-03.

6. [Jump up](#) Heather Lechtman and Linn Hobbs "Roman Concrete and the Roman Architectural Revolution", *Ceramics and Civilization Volume 3: High Technology Ceramics: Past, Present, Future*, edited by W.D. Kingery and published by the American Ceramics Society, 1986; and Vitruvius, Book II:v,1; Book V:xii2.