

# DESIGN & FABRICATION OF SUGARCANE CUTTING & BUNDLING MACHINE

Abhay S. Gunjarkar , Anup D. Bante , Kunal T. Ghagare

Student ( 8<sup>th</sup> Sem ) , Student ( 8<sup>th</sup> Sem ) , Student ( 8<sup>th</sup> Sem )

Department Of Mechanical Engineering

KDK College Of Engineering ,

Nagpur, India

**ABSTRACT** :- To design and fabricate small scale “Sugarcane cutting & bundling machine” for sugarcane harvesting to reduce farmers effort & to increase production of agricultural goods. Compared to manual harvesting this machine has capacity to cut canes in faster rate. It helps improve economic growth of Nation.

**KEYWORDS** :- Sugarcane cutting & bundling machine, reduce harvesting time & effort.

## I. INTRODUCTION

In agriculture cutting & bundling we required maximum man power large amount of money . It is more time consuming process in cutting process we goes through various problems & this process can not be easily solved . After cutting the most of the time is required to collect & bundle the sugarcane . The design of this machine is very easy to use . According to this point of view we are designing the sugarcane cutting & bundling machine to reduce time & effort . There is no skilled person is required to operating this machine . This machine can be use in any working condition . This machine helps to improve economic growth of nation .

## II. LITERATURE REVIEW

[1] Doctor. Sharad S. Choudhari - There project aim at designing & fabricating small scale sugarcane harvester for sugarcane cutting to reduce farmers effort & to increase production of agricultural products . Machine consists of petrol engine & different mechanisms . When compared to manual harvesting by using this machine has a capacity to cut in faster rate & it is economical.

[2] Prof. N . M .Pachkhand - In two days worlds there is need for faster rate of production of agricultural products . In India almost all farmers facing problems of level shortage . Day by day labour wages are increasing & in the same way demand of agriculture products are also increasing . And in the same way demand of agriculture products are also increasing 7 todays world need faster rate of production of agriculture products. This project aims to design and fabricate small scale sugarcane harvesting machine to reduce farmers efforts and to increase production of agricultural products When compared to manual harvesting this machine has more capacity to cuts sugarcane in faster rate . It is economical.

[3] R. R. Price - A fiber optic yield monitoring system is developed for a sugarcane chopper cutter that utilized a duty cycle type approach with three fiber optic sensors mounted in the elevator floor to check sugarcane yield .Field testing of the monitor demonstrated that there was a zero intercept linear relationship between the optical sensor response and the actual sugarcane yields with an R2value of 0.98. The average observed prediction error on 0.5 to 1.6 Mg estimates was 7.5%; though, the magnitude of the error decreased as the harvested area (tonnage) increased, with an estimated error of 0.03% for 57.8 Mg

[4] Suleiman Samaila - Sugarcane harvesting is a labour concentrated operation and its mechanization is a modern development in Nigeria. The difficulties in providing the needed parts for the imported harvesting machines and labour shortages during harvesting periods hamper .

To develop an effective and efficient machine for cutting of sugarcane, a preliminary data on the energy requirement for the cutting and topping of sugarcane must be available for that a simple instrument was developed to calculate the energy requirement for cutting and topping of sugarcane. The instrument consists of: crank, sprocket, chain, freewheel, flange, front hub, spindle, frame and the base support. The result was 15.71 Joules and 23.83 Joules were required for cutting the top and base of the sugarcane respectively.

## III. Design Calculation

### Design of Shaft:

For designing cutter shaft we are consider cutter speed 720 rpm. So, calculating design of shaft as follows,

$$P=2*3.14*N*T/60$$

Where,

P= Power of motor in KW

T= Torque in N-m

N= Speed of motor in rpm

$$745.7=2*3.14*100*T/60$$

$T=71.21 \text{ N-m}$

So, Considering material for shaft is mild steel, Therefore,  $S_{yt}=150 \text{ N/mm}^2$  and  $F.O.S=4$

$f_s=0.5*S_{yt}/F.O.S$

Where;

$f_s$ = Shear stress in  $\text{N/mm}^2$

$f_s=0.5*150/4$

$f_s=18.75 \text{ N/mm}^2$

So, To determine diameter of cutter shaft is as follows,

$d=25\text{mm}$

Diameter of cutter shaft is 25 mm. Checking torsion failure in cutter shaft

$f_s=23.24 \text{ N/mm}^2$

Design is unsafe because shear force is maximum

So, we are increasing the diameter of shaft ,Consider diameter of cutter shaft =30mm

Again checking torsion failure in cutter shaft

$f_s =13.42 \text{ N/mm}^2$

So, Design is safe

Diameter of cutter shaft is 30mm.

#### Diameter of pulley :-

$(71.21*10^3*16)/(\pi*18.75*30^3)=(1-K^4)$

$K= 0.7298$

$K=(D_i/D_o)$

Where;

$D_i$ = Internal diameter of pulley in mm

$D_o$ = External diameter of pulley in mm

$(D_i/D_o)= 0.7297$

$(D_i/D_o)= (N_o/N_i)$

$(30/D_o)= (100/720)$

$D_o=180\text{mm}$

So, Internal diameter of pulley = 30mm ,Outer diameter of pulley=180mm

#### Assumptions;

- 1) As providing chain drive, not much tension produces on shaft so no design consideration in bending stresses on shaft is needed.
- 2) The optimum speed reduction from 720 rpm to 100 rpm is obtained by using sprocket of 30 mm diameter of motor pulley and 180 mm of cutter bar sprocket.
- 3) It is safe by using axial thrust bearing for carrying load of 80 N thrust load of cutter shaft.

#### Design of Cutter:

$T=F*R$

$T=11.58\text{N-m}$

Cutting force=106.5 N

Hence cutter radius=108.73 mm

It is safe to use case hardened cutting steel for cutter. Use standard sugarcane cutter blades available in the agriculture equipment shops locally.

#### IV. CONCEPTUAL VIEW OF MODEL

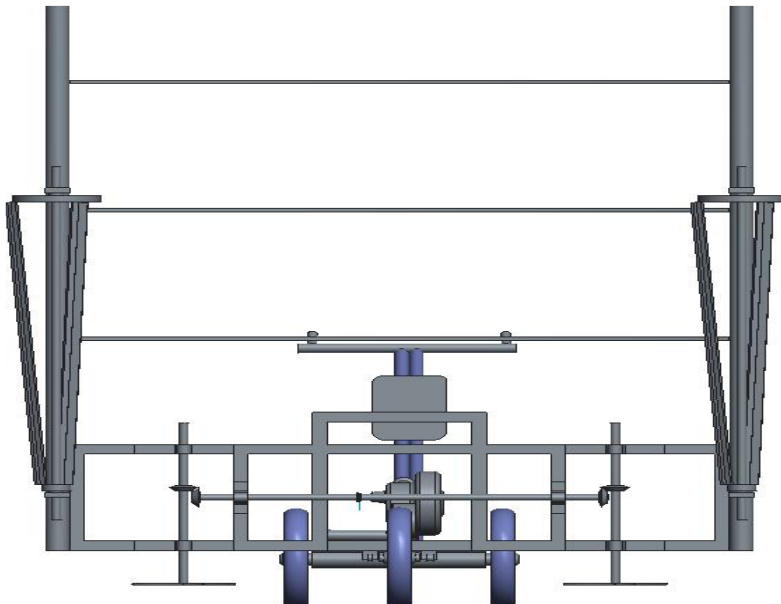

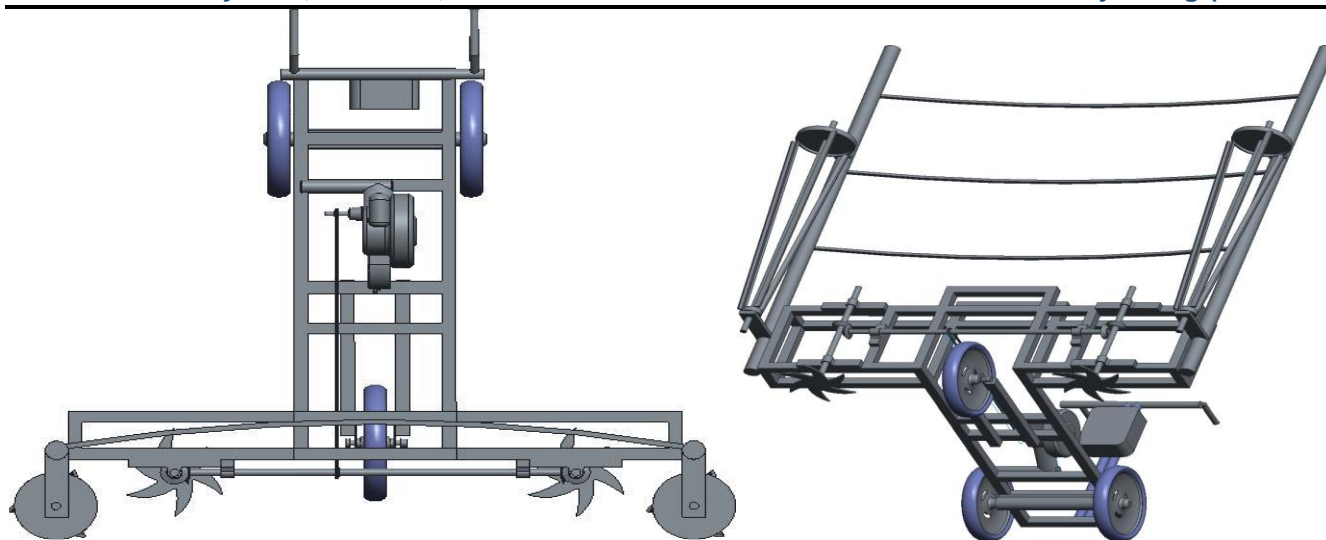

## V. CONCLUSION :-

This design permits to have a capacity to cut approximately half acres of sugarcane cultivated land/hr. Comparing with manual harvesting half of harvesting time and need of labours are reduced. The cost of harvesting is reduced by many folds when compare to manual harvesting.

## VI. LIST OF COMPONENT :-

Name	Dimension	Quantity
Shaft	Diameter = 20mm	3
Bevel gear	Teeth =19	4
Cutter	Diameter =240mm	2
Prime mover	Petrol engine	1
Rotating cone	Upper Dia. = 200mm,& Lower Dia.=60mm	2
NTN Bearing	6204	2
Fuel tank		1
Gear shifter		1

## ACKNOWLEDGEMENT :-

The author would be like to express sincere gratitude to Department of Mechanical Engineering , KDK College of Engineering , Nagpur, India for there help & support.

## REFERENCE :-

- 1..Prof. N.M. Pachkhande, Dhiraj V. Rade and Vikas G. Nagapure, Engineering Application And Technology, 2015
- 2.Ahmed Abdulkadir, "Development of a Tool to Determine the Energy Required to Cut and Top Sugarcane", Department of Agricultural Engineering, Adamawa State Polytechnic Yola, Adamawa State, Nigeria, 2012.
3. V. B. Bhandari, "Design of Machine Elements", Tata Mcgraw Hill Book Company, 2016
- 4.R. S. Khurmi and J.K Gupta, "Machine Design", Tata Mcgraw Hill Book Company, 2005.