

# Drone Based Surveillance Using Drone Augmented Human Vision

Jerry Wilson<sup>1</sup>, Alvin Antony<sup>2</sup>, Lovis Elsa Mammen<sup>3</sup>, Jobin Varghese<sup>4</sup>, Maria Joseph<sup>5</sup>  
<sup>1,2,3</sup>UG Students, <sup>4,5</sup>Assistant Professor,

Department of Electronics and Communication Engineering

Mar Baselios Christian College of Engineering and Technology, Kuttikkanam, Idukki, Kerala, India

**Abstract**— The concept of surveillance drones arises to aid the problem of tracking humans quickly without risking more human lives in desperate times like disasters or terrorist attacks. This paper proposes an aerial surveillance system using an unmanned aerial vehicle (drone). A camera is attached with drone which helps to capture live video and then this video is further used to recognize person from cluttered scenes using KLT face recognition algorithm. This is used for finding missing people from a crowd. It provides an efficient surveillance at an affordable rate for military purposes.

**Keywords**—aerial drones, surveillance, tracking, face recognition, military people.

## I. INTRODUCTION

In recent years, the quadrotor type of Unmanned Aerial Vehicles (UAV) has received abundant scientific consideration and has become the wildest developing technology of independent vehicles. Drones have had several uses in the defence, military, tactical, and modern warfare world. These unmanned aerial systems are used to the air strikes purpose. They travel around suspected locations as controlled from the navy individual and they are operated in certain areas to fulfil army operations of government.

The concept of surveillance drones arises to aid the problem of tracking humans quickly without risking more human lives in desperate times like disasters or terrorist attacks. This paper proposes an aerial surveillance system using an unmanned aerial vehicle (drone). A camera is attached with drone which helps to capture live video and then this video is further used to recognize person from cluttered scenes using KLT face recognition algorithm. This is used for finding missing people from a crowd. It provides an efficient surveillance at an affordable rate for military purposes.

One of the most significant difficulties facing United Nations (UN) Agencies and Nongovernmental Organizations (NGOs) when responding to rapid onset disasters, like floods, earthquakes and hurricanes, is to understand the requirements of the affected population accurately and swiftly. Current direct assessment methods are time consuming and the data captured is often not conducted in a systematic way with the locations sampled not being geographically representative (too clustered and too few), and the subsequent reports being produced too late.

## II. SYSTEM SET UP

An unmanned aerial vehicle system has two parts, the drone itself and the control system. The nose of the unmanned aerial vehicle is where all the sensors and navigational systems are existing. The rest of the body is full of drone technology systems since there is no need for space to put up humans. The engineering materials used to build the drone are highly complex composites designed to absorb vibrations, which decrease the noise produced. These materials are very light weight as shown in Fig. 1.

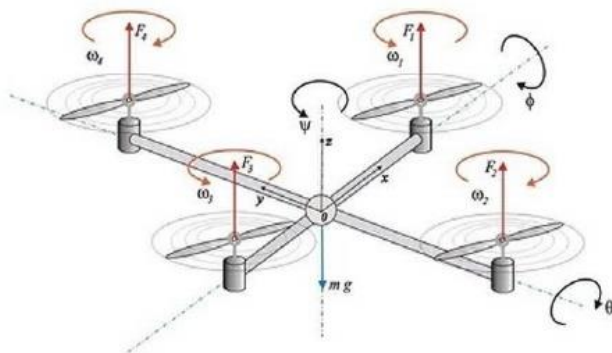

Fig. 1 Configuration

III. BLOCK DIAGRAM

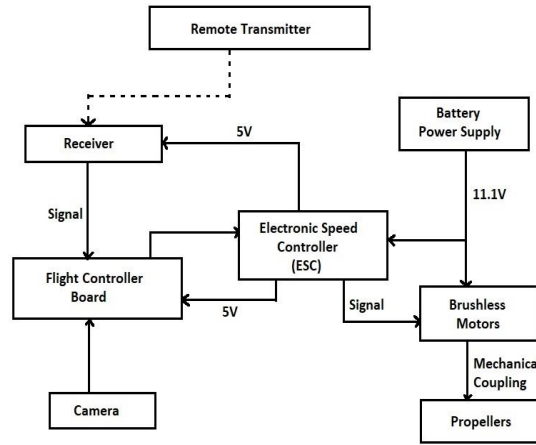

Fig. 2 Drone set up

The working of the drone system is shown in the Fig.2.

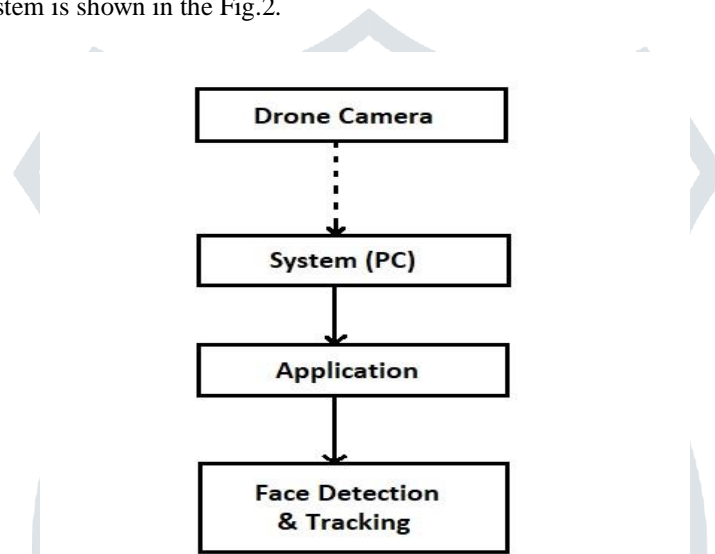

Fig. 3 System

This paper proposes an aerial surveillance system using an unmanned aerial vehicle (drone). A camera is attached with drone which helps to capture live video and then this video is transmitted to a PC and by using KLT algorithm face detection and tracking process is done as shown in Fig. 3..

IV. SYSTEM CONFIGURATION

On the Mission Planner’s Initial Setup | Install Firmware screen select the appropriate icon that matches the frame as shown in Fig. 4. After the GCS detects which board the user is using it will ask to press “OK” within a few seconds as shown in Fig 5.

If all goes well when some status like ,“erase”, “program”, “verify” and “Upload Done” appears. The firmware has been successfully uploaded to the board as shown in Fig 6.

To establish a connection first choose the communication method/channel, and then set up the physical hardware and windows device drivers as shown in Fig. 7. It also contains about Mission Planning; creating automated missions that will run when the ArduPilot is set to AUTO mode as shown in Fig 8.

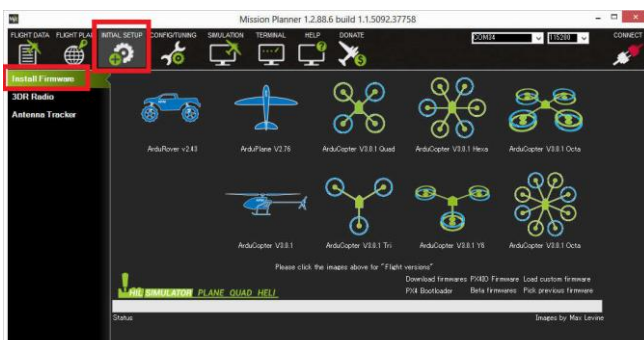

Fig. 4 Initial set up



Fig. 5 Set mode

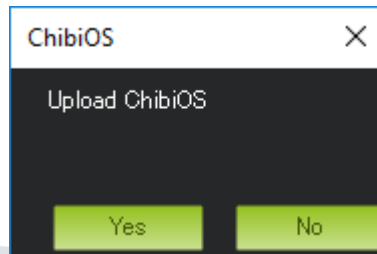

Fig.6 Dialog box

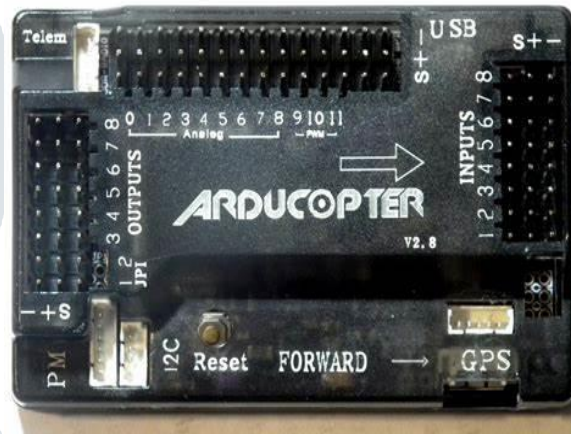

Fig.7 Auto mode

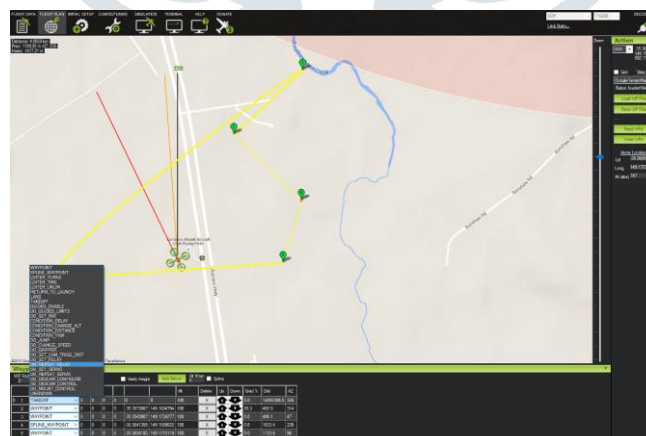

Fig. 8 Location Tracking

### V. FACE DETECTION AND TRACKING USING THE KLT ALGORITHM

This example displays how to automatically detect and track a face by means of feature points. The method in this example keeps track of the face even when the person slopes his or her head or moves toward or away from the camera.

Object detection and tracking are significant in many computer vision applications including activity recognition, automotive safety, and surveillance. This is a simple face tracking system by separating the tracking problem into three parts:

1. Detection of face      2. Identification of facial features

3. Tracking a face

1. Detection a face

Firstly, the algorithm must detect a face. For that the vision cascade object detector object is used to detect the location of a face in a video frame. The cascade object detector uses the viola-jones detection algorithm and a trained classification model for detection. By default, the detector is constructed to detect faces, as shown in Fig. 8.

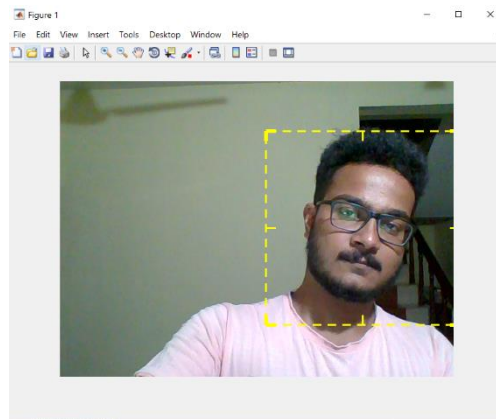

Fig.8 Detect a face

To track the face over time, it uses the Kanade-Lucas-Tomasi (KLT) algorithm. It is possible to use the cascade object detector on every frame; this condition comes from the type of trained classification model used for detection. The example detects the face only once, and then the KLT algorithm tracks the face across the video frames.

2. Identification of facial features

The KLT algorithm tracks a set of feature points across the video frames. Once the detection locates the face, the next step identifies feature points that can be reliably tracked as shown in Fig. 9.

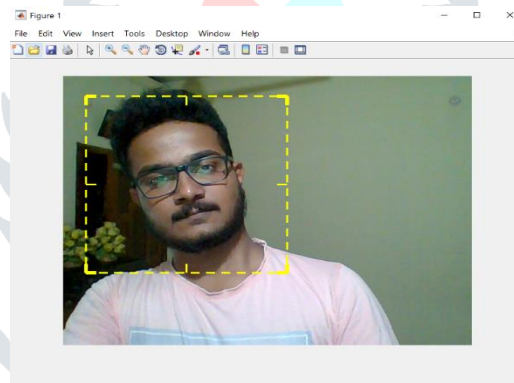

Fig. 9 Identify facial features

With the feature points identified, now we can use the vision.point tracker system object to track them. For each point in the previous frame, the point tracker tries to find the corresponding point in the current frame. Then the estimate geometric transform function is used to estimate the translation, rotation, and scale between the old points and the new points. This conversion is applied to the bounding box around the face. Then a point tracker is created and then enable the bidirectional error constraint to make it more robust in the presence of noise and clutter.

3. Track a face

Track the points from frame to frame, and use estimate geometric transform function to estimate the motion of the face. The copy of the points to be used are created for computing the geometric transformation between the points in the previous and the current frames as shown in Fig 10.

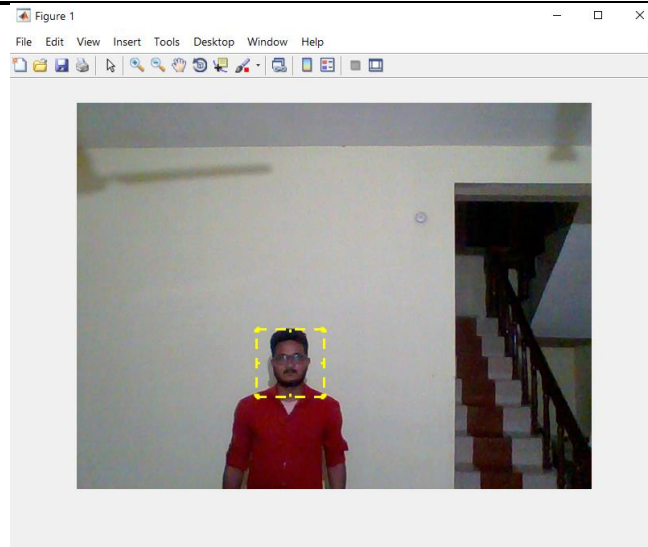

Fig. 10 Track a face

## VI. RESULT AND DISCUSSION

Because of increasing security concerns in real time biometric applications, face recognition is the appropriate solutions. Recently, the most used applications for defense or recognition of attacks are Intrusion Detection System (IDSs).. This paper is different from the existing technology because the algorithm used in the face detection is KLT algorithm. In computer vision, the (KLT) feature tracker is an approach to feature extraction. It is proposed mainly for dealing with the problem that traditional image registration techniques are generally costly. KLT makes use of spatial intensity information to direct the search for the position that produces the best match. It is faster than old techniques for examining far fewer potential matches between the images. By using KLT algorithm for face detection in drone, the detection process will be faster and time consuming will be less.

### References

- [1] Okan Erat, Werner Alexander Isop, Denis Kalkofen and Dieter Schmalstieg, Member, Drone-Augmented Human Vision: Exocentric Control for Drones Exploring Hidden Areas ,IEEE transactions on visualization and computer graphics, pages 1–2, VOL. 24, 2018
- [2] B. Avery, C. Sandor, and B. H. Thomas. Improving spatial perception for augmented reality x-ray vision. In Proc. IEEE VR, pages 79–82, 2009.
- [3] Boult et. al . Generation and vr visualization of 3d point clouds for drone target validation assisted by an operator. In Computer Science and Electronic Engineering (CEECE), 2016 8th, pages 66–70. IEEE, 2016.
- [4] Weiming et al. The MagicBook - Moving Seamlessly between Reality and Virtuality. IEEE Computer Graphics and Applications, 21(1):6–9, 2001.
- [5] Mohammad et al. Human performance issues and user interface design for teleoperated robots. IEEE Transactions on Systems, Man, and Cybernetics, 37(6):1231–1245, 2007.
- [6] Lun et al. Fly a drone safely: Evaluation of an embodied egocentric drone controller interface. Interacting with Computers, 2016.
- [7] C. Coffin and T. Hollerer. Interactive perspective cut-away views for general 3d scenes. In Proc. 3DUI, pages 25–28, 2006.
- [8] Kinjal. Architectural anatomy. Presence, 4(3):318–325, Jan. 1995.
- [9] Kinjal, Darshak, D. Honegger, G. H. Lee, L. Meier, P. Tanskanen, and M. Pollefeys. Vision-based autonomous mapping and exploration using a quadrotor mav. In IROS, pages 4557–4564. IEEE, 2012.
- [10] Tao, A. Alapetite, I. MacKenzie, and E. Mollenbach. The use of gaze to control drones. In Proc. ETRA, pages 27–34, 2014.