

A REVIEW OF LOGIC GATES AND ITS APPLICATIONS

¹Mr. Bavit Garg, ²Ms. Sukhmaneeet Kaur

¹AssistantProfessor, ²Assistant Professor

¹Applied Science Department

¹Gulzar Group of Institutes, Ludhiana, India

Abstract: In this Paper we have discussed different types of logic gates (AND,OR,NOT,NAND,NOR,XOR,XNOR) and corresponding logic tables. The base of any digital computer system are logic gates or circuits which performs logical operations on chunks of information represented digitally. Logic gates work on the basis of binary digits 0 and 1. Any intelligent system with the abilities to take decision comprises of simple logic gates. This paper is an attempt to bring forth the application of digital logic gates in day to day life with some real time applications as well like burglar alarm and security system. Through the study of no. of physical systems e.g. mechanical, optical, electrical, thermal, biological systems it can be said that modeling of any such system can be done logically with the help of a Boolean expression. Accordingly such a system can be studied mathematically. This paper is a generic effort in understanding the Boolean mathematics behind the physical system around.

Index Terms – AND, OR, NOT, NAND, NOR, XOR, XNOR Gates.

I. INTRODUCTION

The word “logic” itself gives us an idea that they work on certain kind of logical operations. Logic Gates are the integral part of digital mathematics. A logic gate is a device performing an elementary Boolean function, producing a logical 0 or 1 output depending on one or several such logical inputs. Implemented with either electronic, optic, mechanical or even biological devices, logic gates can be composed into physical models of all conceivable algorithms or computation. Generally, for every logic gate, we have only one output but in case of inputs, it may vary. But for the logic gate called “NOT” have only a single input and single output. Logic gates are the building blocks of digital circuits in which diodes and transistors are used to perform switching functions. By combining thousands or millions of logic gates, it is possible to perform highly complex operations. A truth table helps us to show the function of a logic gate. It shows the output states for every possible combination of input states.

II. TYPES OF GATES

2.1 AND GATE

An AND gate receives ‘A’ and ‘B’, where A and B are bits and produce output denoted by $A \cdot B$ or $A \wedge B$

$$\text{Where } A \wedge B = \begin{cases} 1 & \text{if } A = 1 \text{ and } B = 1 \\ 0 & \text{otherwise} \end{cases}$$

An AND Gate is shown below:



TRUTH TABLE

2 Input AND gate		
A	B	A.B
0	0	0
0	1	0
1	0	0
1	1	1

2.2 OR GATE

The OR gate receives Inputs ‘A’ and ‘B’, where A and B are bits and produce output denoted by $A + B$ or $A \vee B$

$$\text{Where, } A \vee B = \begin{cases} 1 & \text{if } A = 1 \text{ or } B = 1 \\ 0 & \text{otherwise} \end{cases}$$

An OR Gate is shown below

TRUTH TABLE

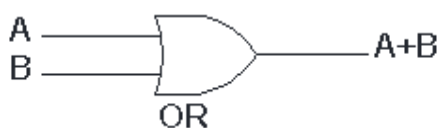

2 Input OR gate		
A	B	A+B
0	0	0
0	1	1
1	0	1
1	1	1

2.3 NOT GATE

A NOT gate (or inverter) receives input A, where A is a bit; and produces output denoted by \bar{A} where

$$\bar{A} = \begin{cases} 1 & \text{if } A = 0 \\ 0 & \text{if } A = 1 \end{cases}$$

The NOT gate is shown below

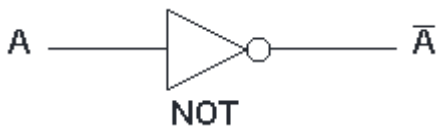

TRUTH TABLE

NOT gate	
A	\bar{A}
0	1
1	0

2.4 NAND GATE

NOT- AND Gate is equal to an AND gate followed by a NOT gate. The outputs of all NAND gates are high if any of the inputs are low. The symbol is an AND gate with a small circle on the output. The small circle represents inversion.

The NAND gate is shown below:



TRUTH TABLE

2 Input NAND gate		
A	B	$\overline{A \cdot B}$
0	0	1
0	1	1
1	0	1
1	1	0

2.5 NOR GATE

NOT-OR gate is equal to an OR gate followed by a NOT gate. The outputs of all NOR gates are low if any of the inputs are high.

The symbol is an OR gate with a small circle on the output. The small circle represents inversion.

The NOR gate is shown below



TRUTH TABLE

2 Input NOR gate		
A	B	$\overline{A+B}$
0	0	1
0	1	0
1	0	0
1	1	0

2.6 EXCLUSIVE-OR GATE (XOR or EOR or EXOR GATE)

The 'Exclusive-OR' gate is a circuit which will give a high output if either, but not both, of its two inputs are high. An encircled plus sign (\oplus) is used to show the EOR operation.

The EOR gate as shown below



TRUTH TABLE

2 Input EXOR gate		
A	B	$A \oplus B$
0	0	0
0	1	1
1	0	1
1	1	0

2.7 EXCLUSIVE-NOR GATE (XNOR or ENOR or EXNOR GATE)

The 'Exclusive-NOR'gate circuit does the opposite to the EOR gate. It will give a low output if either, but not both, of its two inputs are high. The symbol is an EXOR gate with a small circle on the output. The small circle represents inversion.

The ENOR gate as shown below



TRUTH TABLE
2 Input EXNOR gate

A	B	$\overline{A \oplus B}$
0	0	1
0	1	0
1	0	0
1	1	1

III.APPLICATIONS

The applications of logic gates are mainly determined based upon their truth table, i.e their mode of operations. The basic logic gates are used in many circuits like a push button lock, light activated burglar alarm, safety thermostat, an automatic watering system etc. Digital communication cannot happen without logic operations. Daily life application of EOR and ENOR gate can be related to ladder switches used in homes or can be found in water level checker circuits.

3.1 AND GATE

AND gates are used to combine multiple signals, if all the signals are TRUE then the output will also be TRUE. If any of the signals are FALSE, then the output will be false. ANDs aren't used as much as NAND gates; NAND gates use less components and have the advantage that they be used as an inverter. AND gate is used in security alarm. For Example

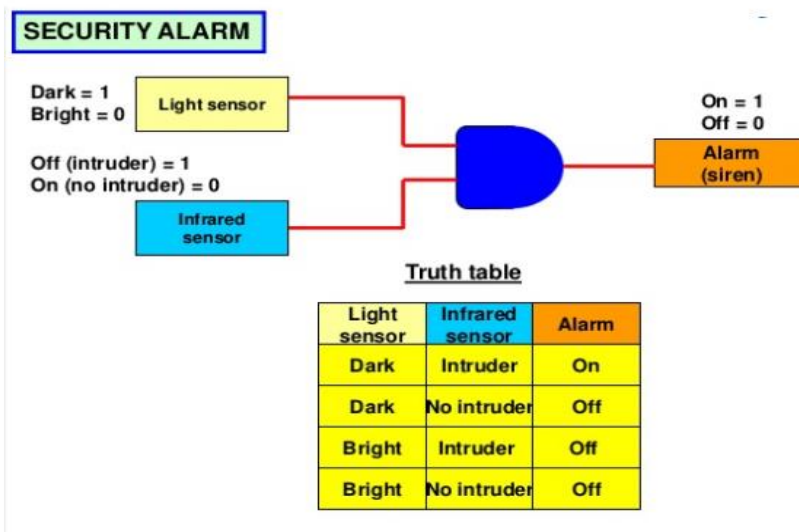

Security Alarm System

3.2 OR GATE

Whenever the occurrence of any one or more than one event is needed to be detected or some actions are to be taken after their occurrence, in all those cases OR gates can be used. For Example

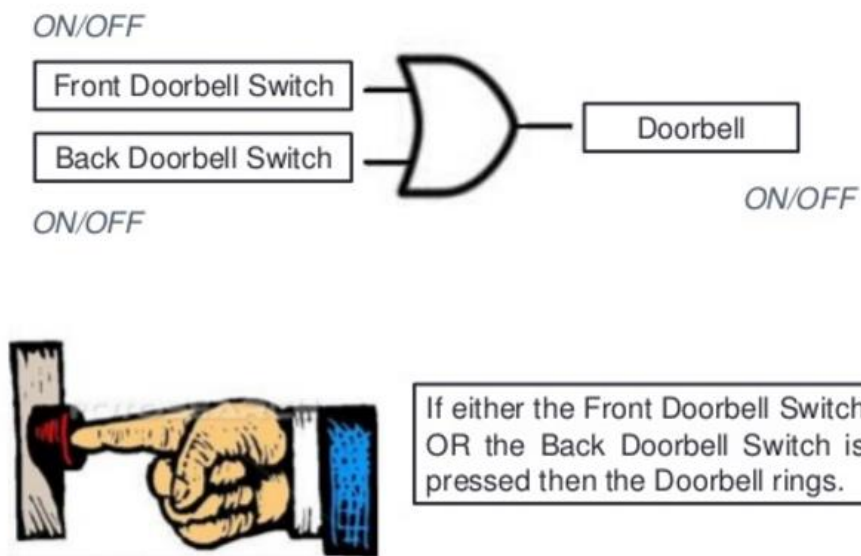

Doorbell System

3.3 NOT GATE

NOT gates are also known as inverter because they invert the output given to them and show the reverse result. Now the CMOS inverters are commonly used to build square wave oscillators which are used for generating clock signals. The advantage of using these is they consume low power and their interfacing is very easy compared to other logic gates. For Example

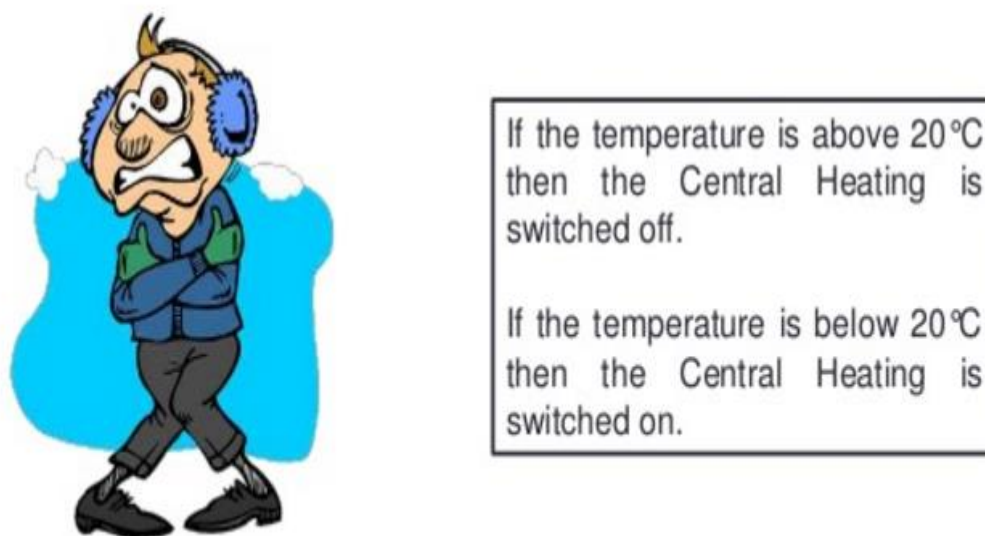
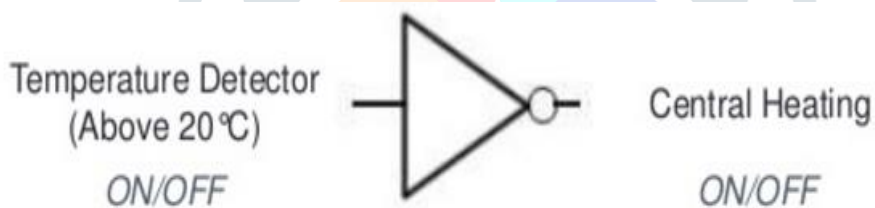

NOT gate based on heating concept

3.4 NAND GATE

3.4.1 Device Failure Alarm System

When all the fans are working, the input to the NAND gate is 111 and the output is 0.

If any one of the fan stops working, the output of the NAND gate becomes 1, which activates the alarm.

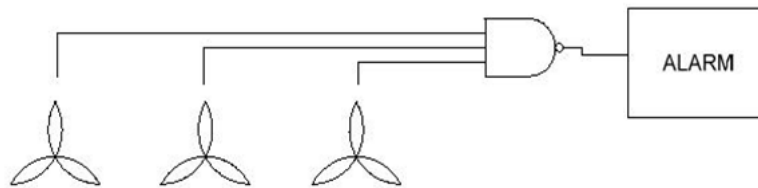

A NAND gate based exhaust fan failure detection system

3.4.2 Burglar alarm

When the switch is closed one input of the NAND gate is LOW. When the LDR is in the light the other input is LOW. This means that if either of these things happen, i.e. the switch is closed or the light is on one of the inputs is LOW, the output is HIGH and the buzzer sounds.

3.4.3 Freezer warning buzzer

When the thermistor is COLD its resistance is LARGE and the input to the NAND gate is high. Since the NAND gate is connected as an INVERTER the output is LOW. As the thermistor warms up its resistance decreases, the voltage across it falls and the input to the NAND gate falls. When it becomes low enough the output becomes HIGH and the buzzer sounds.

3.5.NOR GATE

Washing Machine Controller

A Washing Machine has three sensors to check for washing machine lid open, washing tub filled to minimum level and weight of cloths and water in the tub. If the machine lid is open or the water in the tub is below certain level or the machine is overloaded (weight of water and clothes in the tub is above certain limit), the output of the corresponding sensor is set to 1, producing a 0 at the NOR gate output that switches the machine off.

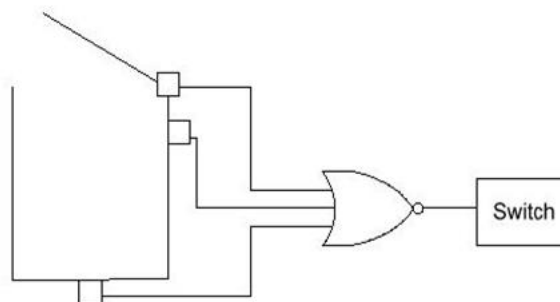

A NOR gate based Washing Machine Controller

REFERENCES

- [1] <https://brilliant.org/wiki/logic-gates/>
- [2] <http://www.ee.surrey.ac.uk/Projects/CAL/digital-logic/gatesfunc/>
- [3] <https://www.quora.com/What-are-the-practical-applications-of-logic-gates>
- [4] <https://www.electrical4u.com/some-common-applications-of-logic-gates/>
- [5] <https://www.slideshare.net/AbidMahmood3/chap-3-11707967>
- [6] file:///C:/Users/king/Downloads/Operation_of_logic_gates_AND_NAND_OR_NOR.pdf
- [7] <https://www.electronicshub.org/introduction-to-logic-gates/>
- [8] <https://electronicsclub.info/gates.htm>
- [9] <https://techterms.com/definition/logicgate>

- [10] http://www.zeepedia.com/read.php%3Fand_or_nand_xor_xnor_gate_implementation_and_applications_digital_logic_design%26b%3D9%26c%3D6
- [11] https://www.answers.com/Q/Uses_of_logic_gate_AND
- [12] Johnsonbaugh, R. 2008. Discrete mathematics. Pearson prentice hall, 486-487
- [13] Haggard, G, schlipf, J & whitesides, S. 2006. Discrete mathematics for computer science. Cengage learning, 98
- [14] Lipschutz, S & Lars Lipson, M. 2010, Discrete mathematics, Tata McGraw Hill, 15.12-15.15
- [15] Liu, C L & Mohapatra, D P. 2008, Elements of Discrete mathematics. Tata McGraw Hill, 528-529

