

# MODELING OF GRID CONNECTED SINGLE PHASE PHOTO VOLTAIC SYSTEM

<sup>1</sup>V. Anil Kumar, <sup>2</sup>M. Vinod Kumar, <sup>3</sup>D.S. Veeranna

<sup>1</sup>PG Student, <sup>2,3</sup>Assistant Professor

<sup>1,2,3</sup>Department of Electrical and Electronic Engineering,

<sup>1,2,3</sup>J.B.Institute of Engineering and Technology, Hyderabad

**ABSTRACT-:** In order to improve the efficiency of photovoltaic generation as well as the power quality, grid-connected inverters for PV generation research was carried out for photovoltaic maximum power point tracking. Based on some current studies on the incremental conductance method, an advanced incremental conductance control algorithm was proposed, which can track maximum power point rapidly and accurately. This paper introduces a direct power control strategy for a grid-connected voltage-source inverter. In this paper we are going to develop a complete computer simulation program of a grid connected solar PV system in distribution power network using MATLAB/ Simulink and SIM Power System tool. This paper aims to grid- connected solar PV system at steady state Finally, according to the principle of inverter control system and based on the analysis on the mathematical model of photovoltaic inverter, a simulation model of that is established based on MATLAB/SIMULINK.

**Keywords:** *Photovoltaic, MPPT, PWM Technique, Photo –Voltaic Panels, MATLAB/SIMULINK.*

## 1. INTRODUCTION

Grid-connected single-phase photovoltaic (PV) systems are nowadays recognized for their contribution to clean power generation. A primary goal of these systems is to increase the energy injected to the grid by keeping track of the maximum power point (MPP) of the panel, by reducing the switching frequency, and by providing high reliability. In addition, the cost of the power converter is also becoming a decisive factor, as the price of the PV panels is being decreased [1]. This has given rise to a big diversity of innovative converter configurations for interfacing the PV modules with the grid. Currently, the state-of-the-art technology is the two-level multi string converter. This converter consists of several PV strings that are connected with dc–dc converters to a common dc–ac converter [2], [3]. This topology features several advantages such as the independent tracking of the MPP of each string to the existing plant. This converter topology can reach peak efficiencies up to 96% [4]. In the last years, multilevel converter topologies have been also considered in PV applications [5]. These converter topologies can generate high-quality voltage waveforms with power semiconductor switches operating at a frequency near the fundamental [6]. Although, in low-power applications, the switching frequency of the power switches is not restricted, a low switching frequency can increase the efficiency of the converter [7]. Additionally, multilevel converters feature several dc links, making possible the independent voltage control and the tracking of the MPP in each string. This characteristic can increase the efficiency of the PV system in case of mismatch

in the strings, due to unequal solar radiation, aging of the PV panels, and different type of the cells or accumulation of dust in the surface of the panels [8]. and the possibility to scale the system by plugging more strings

Along with the development of global industrialization, human's energy demand is increasing day by day. In accordance with the above case, since the mid-twentieth century, countries all over the world are taking measures, which aimed at improving energy efficiency and advancing the structure of the energy to solve the energy crisis and protect the environment[1]. The development of new energy and renewable energy, for purpose of achieving sustainable development, is an urgently problem to be solved. Among them, the solar energy is the focus of the new energy development and utilization. Photovoltaic generation is recognized as one of the most technical contents and the prospects of technology, due to its predominance over environmental protection and sustainability. Inverter technology is the key technology of photovoltaic power grid. As the interface device between solar cells and the power grid

, the grid inverter play a vital role in the new energy development and utilization, affecting the economics and reliability of the photovoltaic (PV) grid generation system directly. Therefore, improve the photovoltaic (PV) grid inverter work performance and transmission quality becomes the focus of research in recent years [2]. According to the photovoltaic array mathematical model, a PV grid inverter simulation model based on MATLAB is established. Having

## 2. GRID TIED SOLAR SYSTEM

A photovoltaic PV generator is the whole assembly of solar cells, connections, protective parts, supports etc. In the present modeling, the focus is only on cell/module/array [3]. Solar cells consist of a p-n junction fabricated in a thin wafer or layer of semiconductor (usually silicon). In the dark, the I- V output characteristic of a solar cell has an exponential characteristic similar to that of a diode [4]. When solar energy (photons) hits the solar cell, with energy greater than band gap energy of the semiconductor, electrons are knocked loose from the atoms in the material, creating electron-hole pairs [5]. These carriers are swept apart under the influence of the internal electric fields of the p-n junction and create a current proportional to the incident radiation. When the cell is short circuited, this current flows in the external circuit; when open circuited, this current is shunted internally by the intrinsic p-n junction diode. Equivalent circuit of a solar cell is a current source in parallel with a diode as shown in Fig. 1. The output of the current source is directly proportional to the light falling on the cell. When light hits the solar cell, the energy of the photons generates free charge carriers. The current source produces the photoelectric current (photocurrent)  $I_{ph}$ . Since the current is dependent upon the radiance.

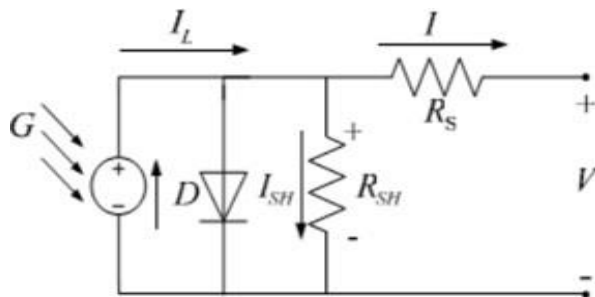

Fig.1. circuit diagram of the PV model.

Thus the simplest equivalent circuit of a solar cell is a current source in parallel with a diode. The output of the current source is directly proportional to the light falling on the cell (photocurrent  $I_{ph}$ ). During darkness, the solar cell is not an active device; it works as a diode, i.e. a p-n junction. It produces neither a current nor a voltage. However, if it is connected to an external supply (large voltage) it generates a current  $I_D$ , called diode (D) current or dark current.

### 2.1 MAXIMUM POWER POINT TRACKING SYSTEM

A Photovoltaic (PV) system directly converts sunlight into electricity. The basic device of a PV system is the PV cell. Cells may be grouped to form panels or arrays. The voltage and current available at the terminals of a PV device may directly feed small loads such as lighting systems and DC motors. [7] A photovoltaic cell is basically a semiconductor diode whose p-n junction is exposed to light. Photovoltaic cells are made of several types of semiconductors using different manufacturing processes.

The incidence of light on the cell generates charge carriers that originate an electric current if the cell is short circuited. The equivalent circuit of PV cell is shown in fig.2 in the above diagram the PV cell is represented by a current source in parallel with diode.  $R_s$  and  $R_p$  represent series and parallel resistance respectively. The output current and voltage from PV cell are represented by  $I$  and  $V$  The I-V Characteristics of PV cell [7] is shown The net cell current  $I$  is composed of the light- generated current  $I_{pv}$  and the diode current  $I_d$ .

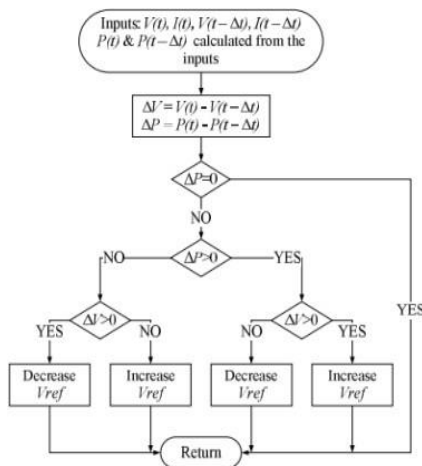

Fig.2. MPPT control algorithm

.MPPT algorithms are necessary in PV applications because the MPP of a solar panel varies with the irradiation and temperature, so the use of MPPT algorithms is required in order to obtain the maximum power from a solar array. There are many MPPT techniques

in MPPT Algorithm, Mostly we are using perturb and observation method. The P&O algorithm is also called —hill-climbing, but both names refer to the same algorithm depending on how it is implemented. Hill-climbing involves a perturbation on the duty cycle of the power converter and P&O a perturbation in the operating voltage of the DC link between the PV array and the power converter. In the case of the Hill-climbing, perturbing the duty cycle of the power converter implies modifying the voltage of the DC link between the PV array and the power converter, so both names refer to the same technique In this method, the sign of the last perturbation and the sign of the last increment in the power are used to decide what the next perturbation should be. If there is an increment in the power, the perturbation should be kept in the same direction and if the power decreases, then the next perturbation should be in the opposite direction. Based on these facts, the algorithm is implemented. The process is repeated until the MPP is reached. Then the operating point oscillates around the MPP. This problem is common also to the In Cond method, as was mention earlier. A scheme of the algorithm is shown.

### 3. MATLAB SIMULATION RESULTS

The structure of PV grid-connected inverter is as shown in fig.3. The system is mainly composed of the former stage of DC - DC converter, intermediate DC bus and the level of DC - AC inverter. The DC - DC converter boosts the DC voltage. Firstly, sample the photovoltaic cells output voltage and current, and compute the collected signals based on improved conductivity incremental control algorithm. And then control the switch state of the DC booster circuit to realize maximum power. The only function of the former stage is to realize MPPT and waveforms shown in Figs.4 to 7.

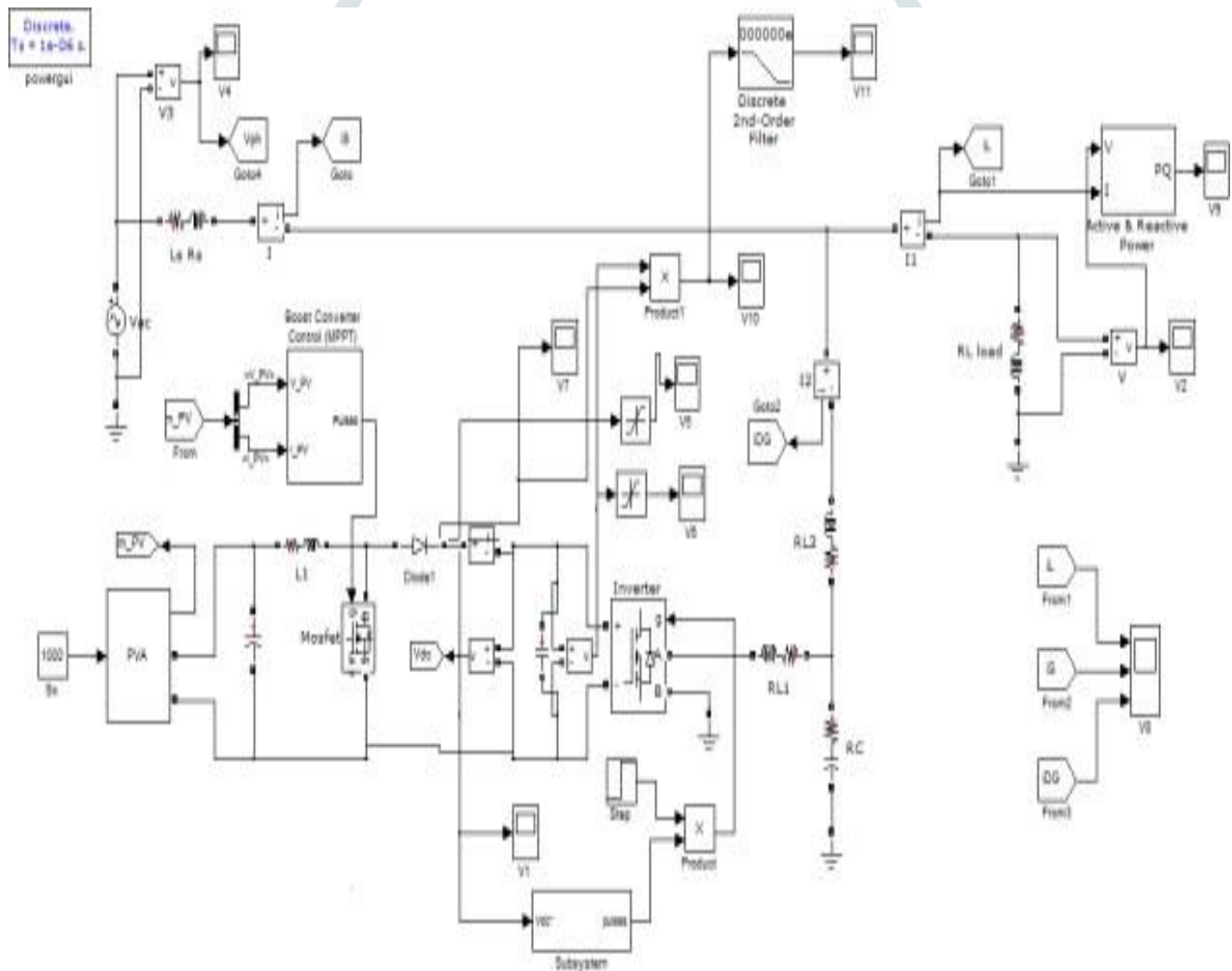

Fig.3. MATLAB Simulation Circuit

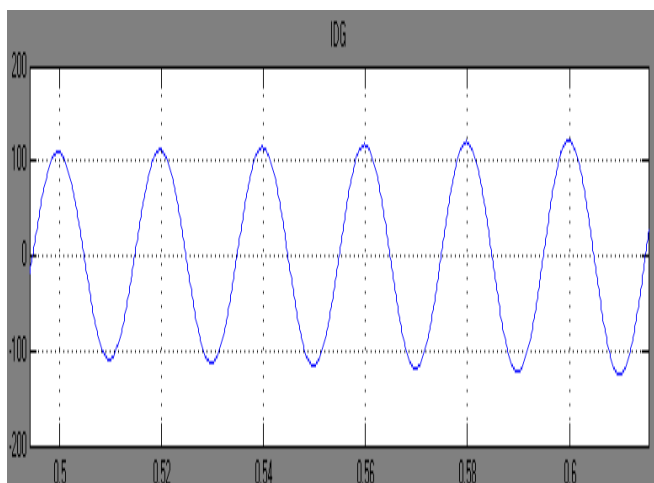

Fig 4a: Load voltage

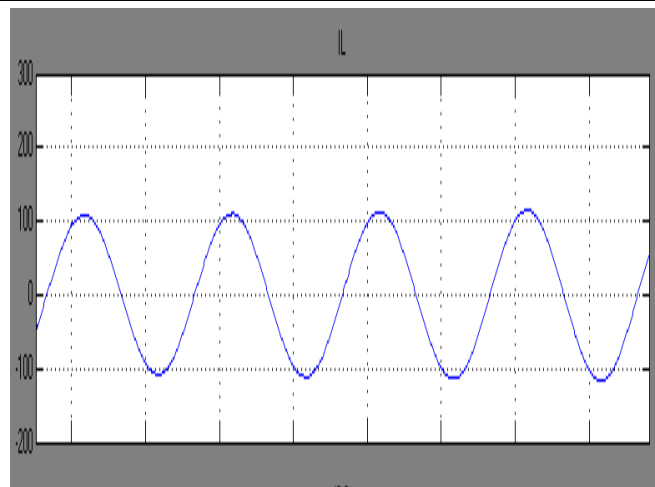

Fig 4b: Load current

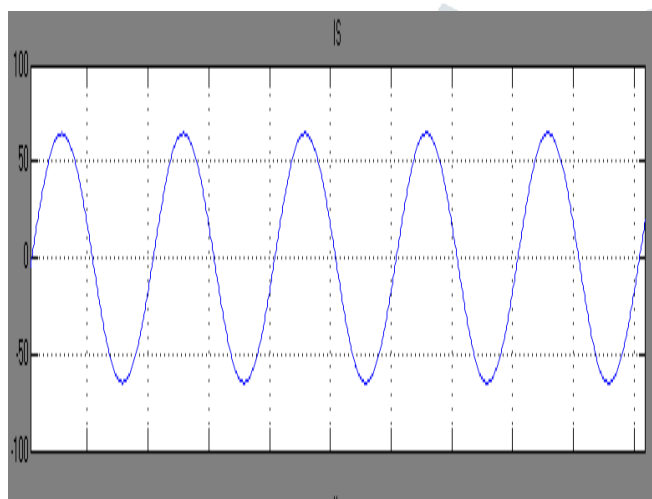

Fig 5. Source current.

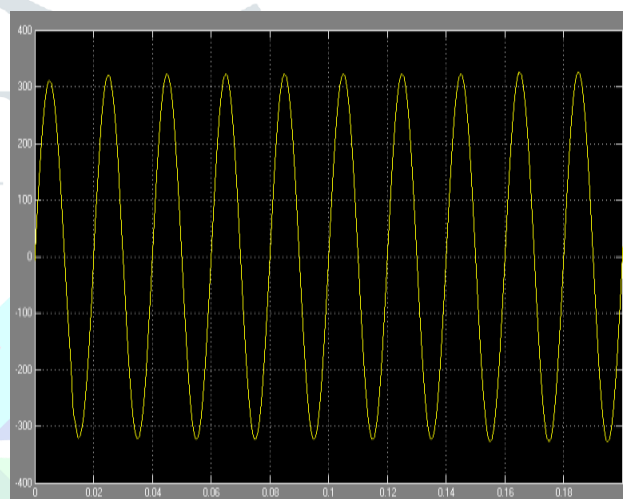

Fig. 6. Load voltage

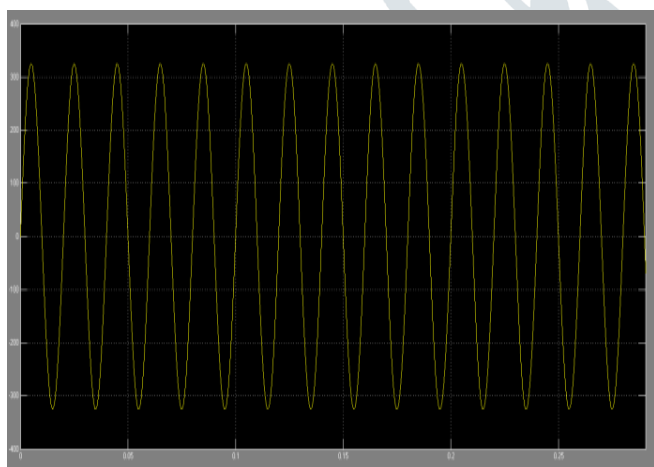

Fig.7.load current

#### 4. Conclusion

This paper concludes that the characteristics of Solar PV cell and Hysteresis Current Control Grid Connected Solar PV system behavior have been developed. The results of the solar PV system provide the current and the inverter tracks the reference current from the solar PV and supplies to the utility grid. According to the mathematical model of the PV array, a simulation model is set up. and the proposed can rapidly and accurately track the maximum power point, in addition, the algorithm guarantees to stabilize the system fast near the maximum power point, so as to improve the efficiency of PV power generation. PV grid-connected inverter control structure is made of two level control modes. the former DC/DC converter achieve maximum power tracking control, the latter inverter keeps the DC bus voltage stable and realizes the connect grid function. Both couple each other through the intermediate DC bus, making the system match simply. The control algorithm has the good rapidity and the stability. The simulation results indicate that the system is stable and has good performance.

#### REFERENCES

- 1) L.A.C Lopes and Lienhardt, A.-M. "A simplified nonlinear power source for simulating PV panels". Power Electronics Specialist, 2003. PESC'03. IEEE 34th.
- 2) Annual Conference on, Volume 4, pp. 1729-1734.15-19 June 2003. B. Kroposki, R. DeBlasio, "Technologies for the New Millennium. Photovoltaics as a Distributed Resource". Power Engineering Society Summer Meeting, 2000. IEEE, Vol. 3, p.p. 1798 – 1801, 16-20 July 2000
- 3) Hansen, P. Lars, H. Hansen and H. Bindner. "Models for a StandAlone PV System". Risø National Laboratory, Roskilde, December 2000, ISBN 87-550-2776-8.
- 4) G. Walker, "Evaluating MPPT converter topologies using a MATLAB PV model," Journal of Electrical & Electronics Engineering, Australia, IEAust, vol.21, No. 1, 2001, pp.49-56.
- 5) Lorenzo, E. (1994). Solar Electricity Engineering of Photovoltaic Systems. Artes Graficas Gala, S.L., Spain.
- 6) Francisco M. González-Longatt publish " Model of Photovoltaic Module in Matlab™ " of 2do congreso iberoamericano de estudiantes de ingeniería eléctrica, electrónica y computación (ii cibelec 2005).
- 7) Nasrudin Abd Rahim, Jeyraj Selvaraj and Krismadinata of Hysteresis Current Control and Sensorless MPPT for Grid-Connected Photovoltaic Systems .
- 8) C. H. Wu, The Research of Inverter for PV Generation,
- 9) Shanghai: Shanghai University, 2008
- 10) X. Zou, and L. Z. YI, "Constant-frequency Hysteresis Current Control of PV grid-connected Inverter," Electric Power Automation Equipment, 2008, 4(28), pp. 58-62.
- 11) L. Pan, "Photovoltaic inverter design and control," Energy and Energy Efficiency, 2011, pp. 83–85.
- 12) W. D. Wang, Z.K. Wen, "Matlab Simulation of Photovoltaic Arrays," Electroinc Components & Device Applications, 2010, 12(9), pp. 89- 90.
- 13) Z. J. Tang, C. L. Wang, X. F. Fang, "MPPT Implementation Strtegy Based on the Conductance Increment Method," Power Electronics, 2011, 45(4), pp. 73-75.
- 14) X. Y. Li, X. Wang, F. Zheng, "The MPPT Improved Algorithm and Simulation under Changing Irradiance of Grid- Connected PV Systems," Energy Technology, 2009, 30(5), pp.272-279.
- 15) H. Z. Yang and X. M. Jin, "Research on Grid-Connected Photovoltaic Inverter of Maximum Power Point Tracking," The University of Traffic, 2004, 28(2), pp.65-68.