

ROLE OF AN AUTOMATED-AGRICULTURAL SEED PLANTER: AN INDIAN CONTEXT

Harpreet Singh^{1*}, Betala Venkata Sai Krishna², K Charan Teja²

¹Assistant Professor and ²Graduate Student, School of Mechanical Engineering,
Lovely Professional University, Phagwara 1444 11 Punjab, India

ABSTRACT

This paper aims at reducing the manual energy involved in the transplanting and saving time and money. With less effort this will offer perfect planting. Various crops on commercial farms and this in effect needs high-capacity and powerful machines. This paper is presenting the research directions for researchers in the area of modelling of agricultural equipments for the advancements of agriculture. That purpose can ease the labor cost, farmers' time, and energy saving which is the betterment for the agricultural sector. We believe that this paper is presenting the research directions for researchers in the area of modelling of agricultural equipments for the advancements of agriculture.

Keywords: solar-energy; automatic seed planter; 4-wheeler; agricultural equipment

1. INTRODUCTION

Automation has become the center of modern manufacturing so that, without automating its activities, no company can thrive in a competitive market. In addition, the term automation refers generally to the use of computers and other automated equipment to perform tasks otherwise performed by human labour. Automation is used to monitor structures and to control processes, raising the need for human interaction. Manufacturers now try automation methods tailored to their needs and purposes. For a number of purposes, businesses automate their operations. Increasing profitability is usually the primary priority for businesses that want competitive advantages. Many reasons for automation include unsafe work conditions and high labor costs in these areas (Raut *et al.*, 2016).

Agriculture leads to their role in the Indian economy, and will remain so for a long time to come. Seed seeding by hand would cause inefficient and inaccurate seed seeding. This system will do row by row seed sowing. Several strips are used at one time for sowing cycle. The high performance and accuracy of this process (Hung *et al.*, 2013; Cay *et al.*, 2018).

2. DESIGNING ASPECTS OF AUTOMATIC SEED PLANTER

It includes designing and drafting of the model required to be developed (Fig. 1-3).

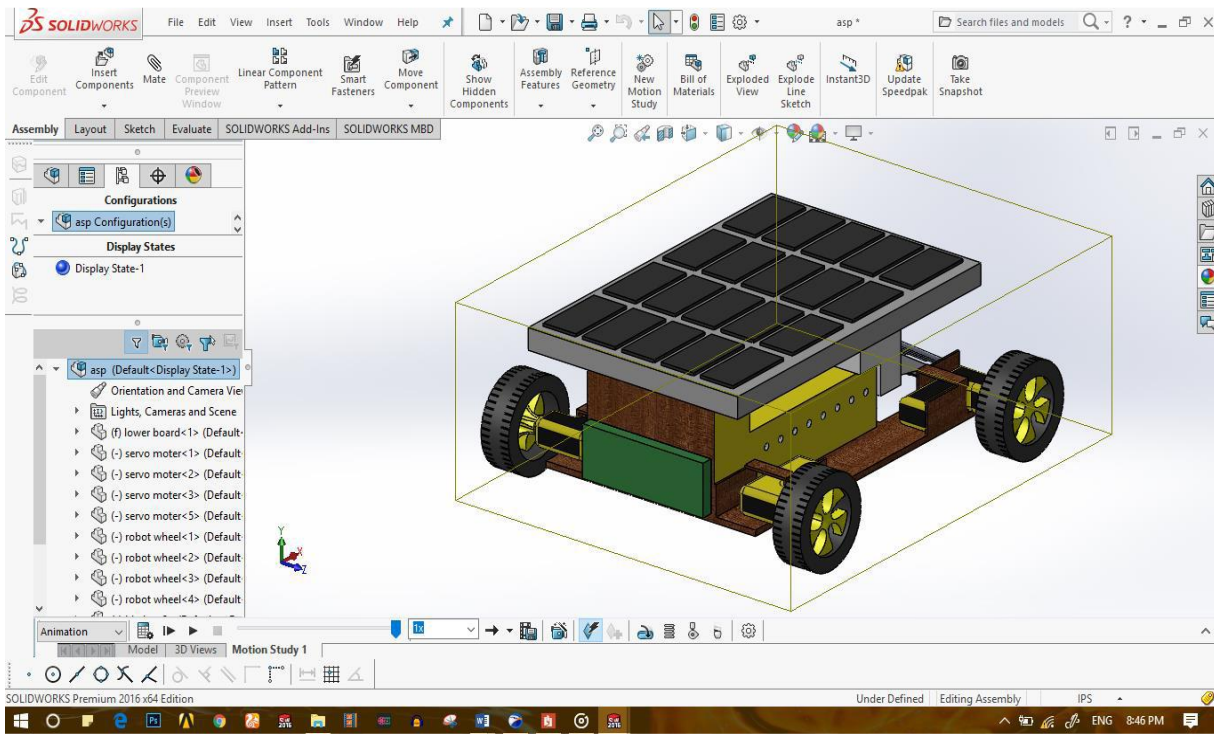

Fig. 1. CAD model of automated seed planter assembly

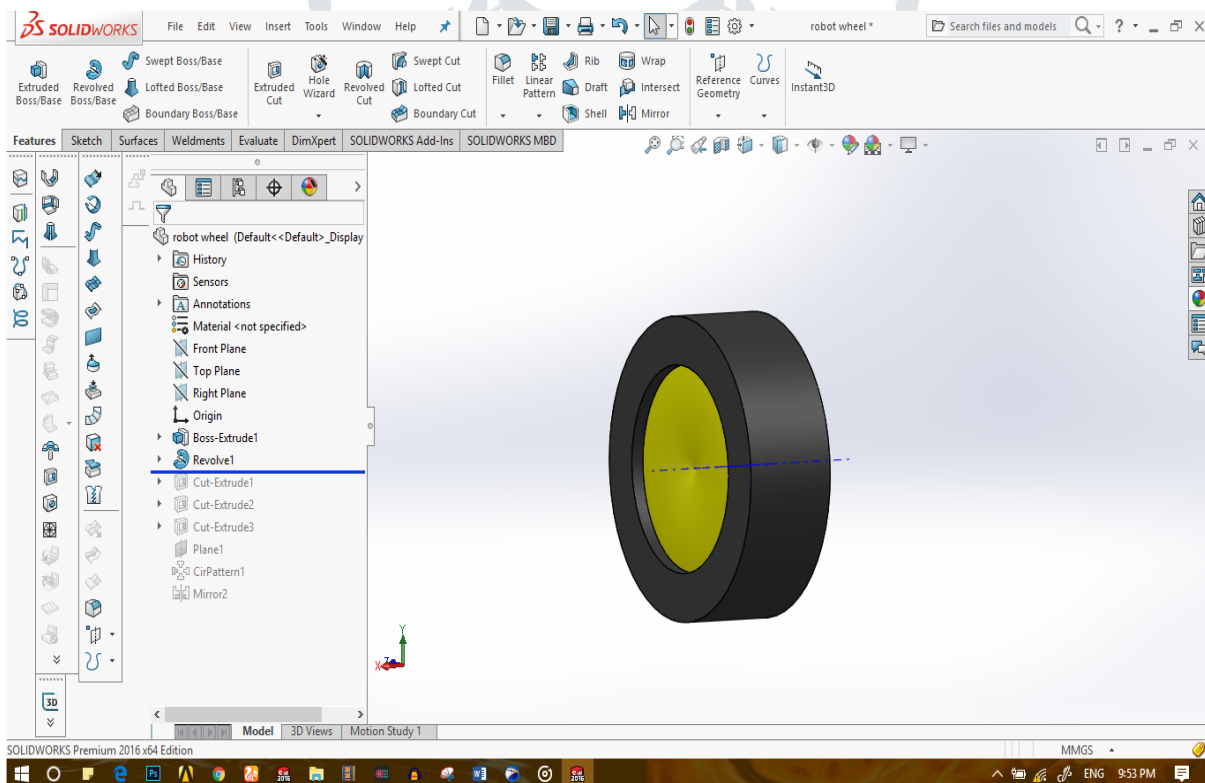

Fig. 2. Designing of wheel

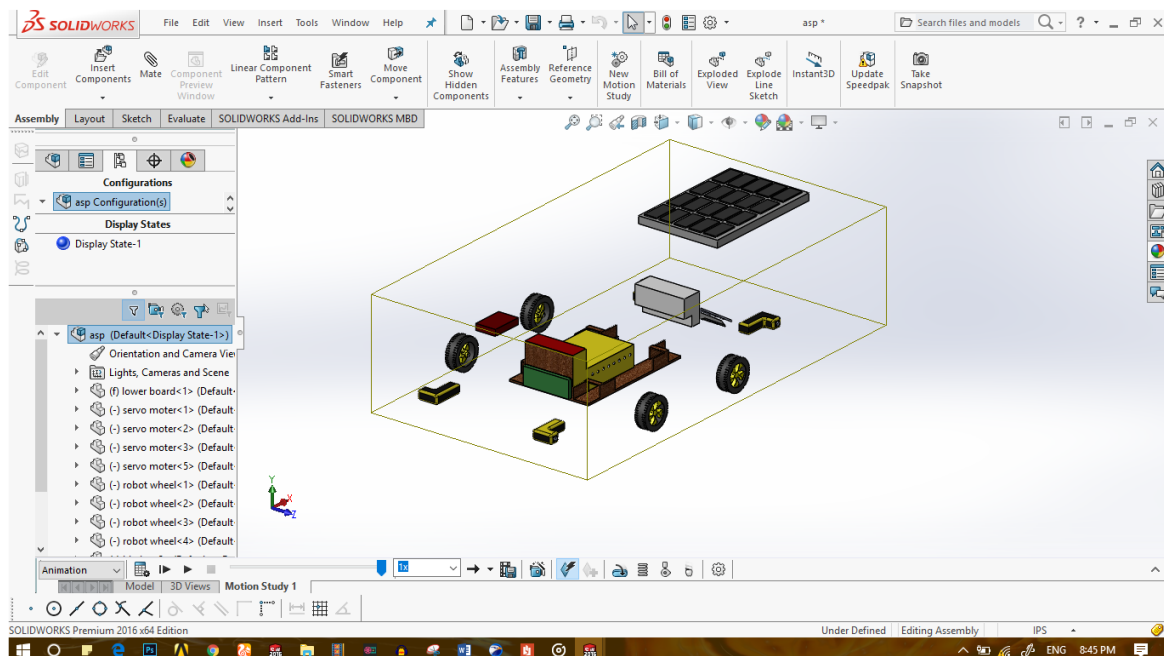

Fig. 3. Exploded view of automatic seed planter

3. Mechanical properties

In mechanical properties we talk about the various strengths, elongation, forces, ratios, and modulus.

Table 1. Mechanical properties of AISI 4130 STEEL

TENSILE STRENGTH	435Mpa
YIELD STRENGTH	435Mpa
ELONGATION AT BREAK	25.5
SHEAR MODULUS	205Gpa
POISSONS RATIO	0.29

3.1 Applications

- It is widely used in automotive industries due to its strength to weight ratio. It has high tensile strength and good yield strength.
- The presence of chromium in the material makes it corrosion resistant so that it can be used to make body panels of automobiles.
- Aluminium has very low weight as compared to other materials .Thus it does not increase the overall weight of the vehicle.

4. CONCLUSIONS

It is widely used in automotive industries due to its strength to weight ratio. It has high tensile strength and good yield strength. The presence of chromium in the material makes it corrosion resistant so that it can be used to make body panels of automobiles. Aluminum has a very low weight as compared to other materials. Thus it does not increase the overall weight of the vehicle. The motherboard of an Arduino is a based on microcontroller. At one time, the microcontroller-based super computer can run multiple programs, and its convenient to implement. A Linux operating system in collaboration with Raspberry Pi is a multi-purpose system, and it can have ability to run many programs.

References

- i. Adisa, A.F. and Braide, F.G. (2012), "Design And Development of Template Row Planter", *Transnational Journal of Science and Technology*, Vol. 2, 27-33.
- ii. Cay, A., Kocabiyik, H. and May, S. (2018), "Development of An Electro-Mechanic Control System for Seed-metering Unit of Single Seed Corn Planters Part I: Design and Laboratory Simulation", *Computers & Electronics in Agriculture*, Vol. 144, 71-79.
- iii. Hung, C., Nieto, J., Taylor, Z., Underwood, J. and Sukkarieh, S. (2013), "Orchard Fruit Segmentation using Multi-spectral Feature Learning", *IEE/RSJ International Conference on Intelligent Robot System Tokyo, Japan*, 5314-5320.
- iv. Kyada, A and Patel, D.B. (2014), "Design and Development of Manually Operated Seed Planter Machine", *5th International & 26th All India Manufacturing Technology, Design and Research Conference (AIMTDR)*, IITGuwahati, Assam, India,
- v. Raut, P., Shirwale, P. and Shitole, A. (2016), "A Survey On Smart Famer Friendly Robot Using Zigbee", *International Journal of Emerging technology and Computer Science*, Vol. 1, 1, 1-5.
- vi. Shelke, P.P. (2011), "Frontline Demonstration on Bullock-drawn Planter Enhances Yield of Soya Bean Crop", *International Journal of Farm Science*, Vol. 1, 2, 123-128.
- vii. Shrinivas, R., Zanwar, R. and Kokate, D. (2012), "Advanced Agriculture System", *International Journal of Robotics and Automation*, Vol. 1, 2, pp. 107-112.
- viii. Swetha, S. and Shreeharsha, G.H. (2015), "Solar Operated Automatic Seed Sowing Machine", *International Journal of Advanced Agricultural Sciences and Technology*, Vol. 4, 1, 67-71.