

# DECOUPLED ACTIVE AND REACTIVE POWER CONTROL FOR LARGE-SCALE GRID-CONNECTED PHOTOVOLTAIC SYSTEMS USING CASCADED MODULAR MULTILEVEL CONVERTERS

A.Anjum<sup>1</sup> Y.Keerthi<sup>2</sup>  
<sup>1,2</sup>Student of B.Tech(EEE)

K.Chandramouli  
Associate Professor of EEE  
kodemchandramouli@gmail.com

Dr.M.Ramesh  
Professor & HOD of EEE  
marpuramesh223@gmail.com

Vaageswari College Of Engineering, Karimnagar

**Abstract:-**This paper presents a robust PI controller design for a three-phase grid-connected photovoltaic (PV) system to control the Active and Reactive power flow in the grid and the dc-link voltage for extracting maximum power from PV units by using a Cascaded multilevel converter. However, power distribution and control in the cascaded PV system faces tough challenge on output voltage over modulation when considering the varied and non-uniform solar energy on segmented PV arrays. This paper addresses this issue and proposes a decoupled active and reactive power control strategy to enhance system operation performance. The relationship between output voltage components of each module and power generation is analyzed with the help of a newly derived vector diagram by using a PI which illustrates the proposed power distribution principle. Finally, a 3-MW, 12-kV PV system with the proposed control strategy is modeled and simulated in MATLAB/Simulink software and the performance also analyzed by using both controllers.

## I.INTRODUCTION

In response to global concerns regarding the generation and delivery of electrical power, photovoltaic (PV) technologies are gaining popularity as a way of maintaining and improving living standards without harming the environment. To extract maximum power from the PV system [1], a robust controller is required to ensure maximum power-point tracking (MPPT) [1]–[3] and deliver it to the grid through the use of an inverter [4]–[6]. Robustness is essential since the power output of PV units varies with changes in atmospheric conditions. Thus, the controller must be robust enough to provide a tighter switching scheme for the inverter to transfer maximum power into the grid over a wide range of operating conditions with a short transient period. In a grid-connected PV system, control objectives are met by using a pulse-width modulation (PWM) scheme based on two cascaded control loops [7]. The two cascaded control loops consist of an outer voltage-control loop to track the maximum power point (MPP) and an inner current control loop to control the duty ratio for the generation of a sinusoidal output current which needs to be in phase with the grid voltage for unity power factor operation [7].

The current loop is also responsible for maintaining power quality (PQ) and for current protection that has harmonic compensation. Linear controllers are widely used to operate PV systems at MPP [8]–[13]; however, most of these controllers do not account for the uncertainties in the PV system. Over the past few decades, one of the most important contributions in the field of control theory and applications has been the development of robust linear controllers for linear systems in the presence of uncertainties through the control scheme which is often obtained from linear matrix inequality (LMI) methods. A feed forward approach to control the current and dc-link voltage, and the robustness is assessed through modal analysis. A robust fuzzy-controlled PV inverter is presented in this for the stabilization of a grid-connected PV system along with Decoupled control of Active and Reactive power.

Proper reactive power compensation can significantly improve the system reliability, and in the meantime help the MPPT implementation for the cascaded module under unsymmetrical condition as well as comply with the system voltage requirement simultaneously. A reactive and active power control strategy has been applied in cascaded PV system with isolated dc–dc converters.

If symmetrical active power comes from each module, active and reactive power can be equally distributed into these modules under traditional power control. However, if unsymmetrical active power is generated from these modules, this control strategy will not be able to achieve decoupled active and reactive power control. Reactive power change is along with the active power change at the same direction, which may aggravate output voltage over modulation during unsymmetrical active power outputs from segmented PV arrays.

In order to solve the aforementioned issues, this paper proposes a large-scale grid-connected cascaded PV system including current-fed dual-active-bridge (CF-DAB) dc–dc converters and cascaded multilevel inverters as shown in Fig. 1. A decouple active and reactive power control system is developed to improve the system operation performance. Reactive power from each PV converter module is synchronously controlled to reduce the over modulation of PV converter output voltage caused by unsymmetrical active power from PV arrays. In particular, the proposed PV system allows a large low-frequency dc voltage ripple for each PV converter module, which will not affect MPPT achieved by CF-DAB dc–dc converters. As a result, film capacitors can be applied to replace the conventional electrolytic capacitors, thereby enhancing system lifetime.

## II. SYSTEM CONFIGURATION AND POWER FLOW ANALYSIS

### A. System Configuration

The proposed large-scale grid-connected PV system is presented in Fig. 1, which demonstrates a three-phase two-stage power conversion system. It includes  $n$  cascaded multilevel

inverter modules for each phase, where each inverter module is connected to  $j$  cascaded CF-DAB dc–dc converter modules with high voltage insulation. This configuration features many impressive advantages comparing with traditional PV systems with line-frequency transformer. The cascaded multilevel inverters are directly connected to the grid without big line-frequency transformer, and the synthesized output voltage from cascaded modules facilitates to be extended to meet high grid voltage requirement due to the modular structure. Each dc–dc converter module is interfaced with segmented PV arrays and therefore the independent MPPT can be achieved to harvest more solar energy.

Moreover, it is immune to the double-line-frequency power ripple propagation into PV arrays. Particularly, the ground leakage current and PV insulation issues are effectively suppressed. In addition, flexible control strategies are able to be explored and applied in this topology owing to more control variables and control degree-of-freedom. Although there is no accurate number about the cost benefits comparing with the traditional PV system with line-frequency transformer, it is obvious that the proposed PV system will have lower cost due to high power density and modular structure, which will significantly reduce the cost of the power platform using to install the PV system.

The photovoltaic effect is the creation of voltage or electric current in a material upon exposure to light and is a physical and chemical phenomenon. The photovoltaic effect is closely related to the photoelectric effect.

In fact, they involve the emission of electrons by the absorption of energy from light. ... The main difference between the two processes is that in the photoelectric effect, the electrons are emitted to the space whereas, in photovoltaic effect, the emitted electrons directly enter a new material.

Photoconductivity is an optical and electrical phenomenon in which a material becomes more electrically conductive due to the absorption of electromagnetic radiation such as visible light, ultraviolet light, infrared light, or gamma radiation.

TABLE I  
SYSTEM CIRCUIT PARAMETERS IN SIMULATION

	Parameters	Symbol	Value
PV inverter modules in each phase	Number	$n$	4
	DC Capacitor voltage	$V_{dcki} (k=1,2\dots n; i=a,b,c)$	3000 V
	DC Capacitor size	$C_{in}$	400 $\mu$ F
	Filter inductor	$L_f$	0.8 mH
	Switching frequency	$f_{sw\_AC}$	5 kHz
CF-DAB DC-DC converter module	Number	$j$	5
	Capacitor voltage in low voltage capacitor	$V_{LV}$	300V
	Capacitor voltage in low voltage capacitor	$V_{HV}$	600V
	Transformer turn ratio	$N$	2
	PV arrays output voltage	$V_{pvki\_r} (k=1,2\dots n; i=a,b,c; r=1,2\dots j)$	100 V - 200 V
	Leakage inductor	$L_s$	2.5 $\mu$ H
	DC inductor value	$L_{dc1}, L_{dc2}$	12.5 $\mu$ H
	Capacitor in high voltage side	$C_{HV}$	2 mF
	Capacitor in low voltage side	$C_{LV}$	300 $\mu$ F
	PV arrays output capacitor	$C_{PV}$	100 $\mu$ F
	Switching frequency	$f_{sw\_DC}$	50 kHz
Grid (three phase)	Rated real power	$P_g$	3 MW
	Rated reactive power	$Q_g$	1.5 MVAR
	Rated RMS line-line voltage	$V_{gl-L}$	12 kV

### B. Power Flow Analysis

In the cascaded PV system, power distribution between these modules is primarily dominated by their respective ac output voltage because the same grid current flows through these modules in each phase as shown in Fig. 1.

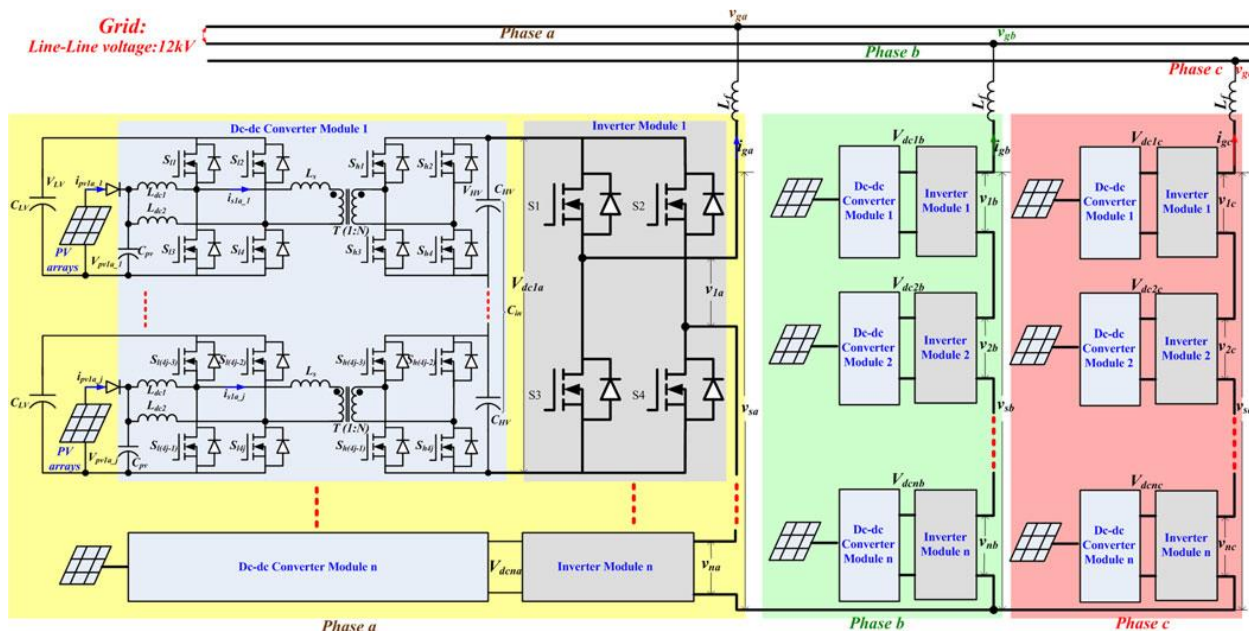

Fig. 1. Proposed grid-connected PV system with cascaded multilevel converters at 3 MW.

Vector diagrams are derived in Fig. 2 to demonstrate the principle of power distribution between four PV inverter modules in phase a. The same analysis can be applied for phases b and c. Considering the relative stability of the grid voltage,  $v_{ga}$  is used for the synchronous signal. The  $\alpha$ -axis is in phase with grid voltage and the  $\beta$ -axis lags the  $\alpha$ -axis by  $90^\circ$  as shown in Fig. 2(a). The d-axis is aligned with the grid voltage by the phase-locked loop (PLL) control [8] and the q-axis lags the d-axis by  $90^\circ$ .

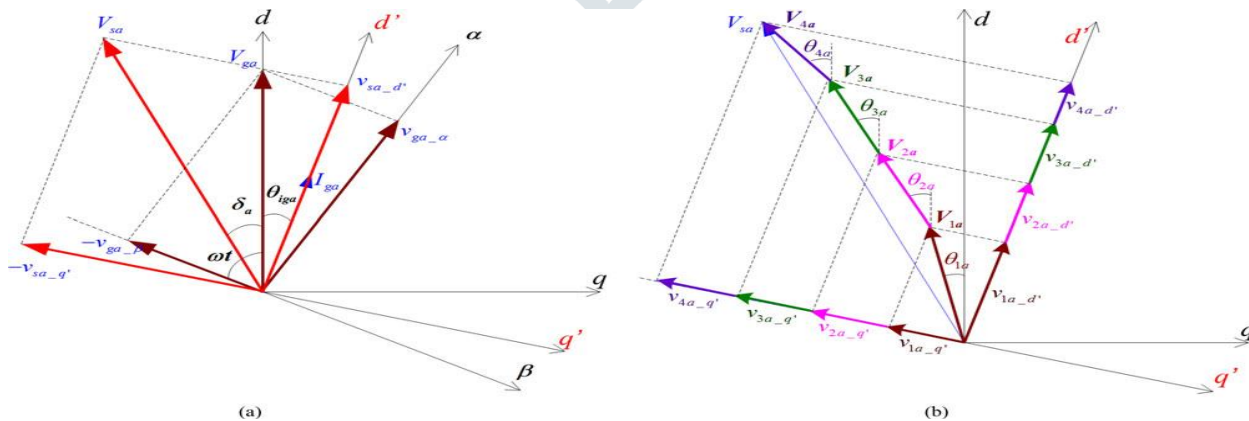

Fig. 2. Vector diagrams showing relation between  $\alpha\beta$  frame, dq frame, and d\_q\_ frame. (a) The relationship between the grid current, grid voltage, and inverter output voltage in phase a. (b) The voltage distribution of PV inverter in phase a.

The components of grid voltage in  $\alpha\beta$  stationary frame and dq rotating frame can be written in (1) and (2), respectively.

$$\begin{cases} v_{ga-\alpha} = V_{ga} \sin(\omega t) \\ v_{ga-\beta} = -V_{ga} \cos(\omega t) \end{cases} \quad (1)$$

$$\begin{bmatrix} v_{ga-d} \\ v_{ga-q} \end{bmatrix} = \begin{bmatrix} \sin(\omega t) & -\cos(\omega t) \\ \cos(\omega t) & \sin(\omega t) \end{bmatrix} \begin{bmatrix} v_{ga-\alpha} \\ v_{ga-\beta} \end{bmatrix} \quad (2)$$

where the  $\omega$  is the system fundamental frequency,  $V_{ga}$  is the amplitude of the grid voltage,  $v_{ga-d} = V_{ga}$ ,  $v_{ga-q} = 0$ .

The grid current is relatively stable to the grid voltage in steady state. Therefore, the new d-axis ( $d_{-}$ ) can be aligned with the grid current. It is obvious that the  $d_{-}$ -axis component of the inverter output voltage  $v_{sa-d_{-}}$  determines the active power generation, and the  $q_{-}$ -axis component  $v_{sa-q_{-}}$  decides the reactive power output. Fig. 2(b) describes clearly the power distribution between four PV inverter modules under different active power generation. The output voltage of the total inverter  $V_{sa}$  is synthesized by the four inverter module output voltage with different amplitude and angles. In particular, the  $v_{ka-d_{-}}$  and  $v_{ka-q_{-}}$  ( $k = 1, 2, \dots, 4$ ) can be independently controlled to implement the decoupled active and reactive power control.

### III. CONTROL SYSTEM DESIGN

Fig. 3 shows the proposed control system of the grid connected cascaded PV converters including CF-DAB dc-dc converters control and cascaded multilevel inverters control in phase a. The same control system can be applied in phases b and c.

#### A. CF-DAB DC-DC Converters Control

Fig. 3(a) shows the CF-DAB dc-dc converters control for one unit of dc-dc converter module 1 in Fig. 1 [32]. The same control can be used to other units. Due to the dual-active-bridge structure, this control has two degrees of freedom: the duty cycle  $D$  and the phase shift angle  $\phi$ , by which the PV voltage  $V_{pv1a1}$  and LVS dc-link voltage  $V_{LV}$  are controlled, respectively.  $V_{pv1a1}$  is directly controlled by the duty cycle  $D$  so that it can be well kept at the reference voltage  $V^*_{pv1a1}$  which is generated from MPPT algorithm [32]. Usually the bandwidth of the duty cycle loop is about several kHz (e.g., 10 kHz in this paper), which is much higher than 120 Hz; thus, the double-frequency component in the LVS or HVS is blocked and high utilization factor of MPPT is reached in the PV side.

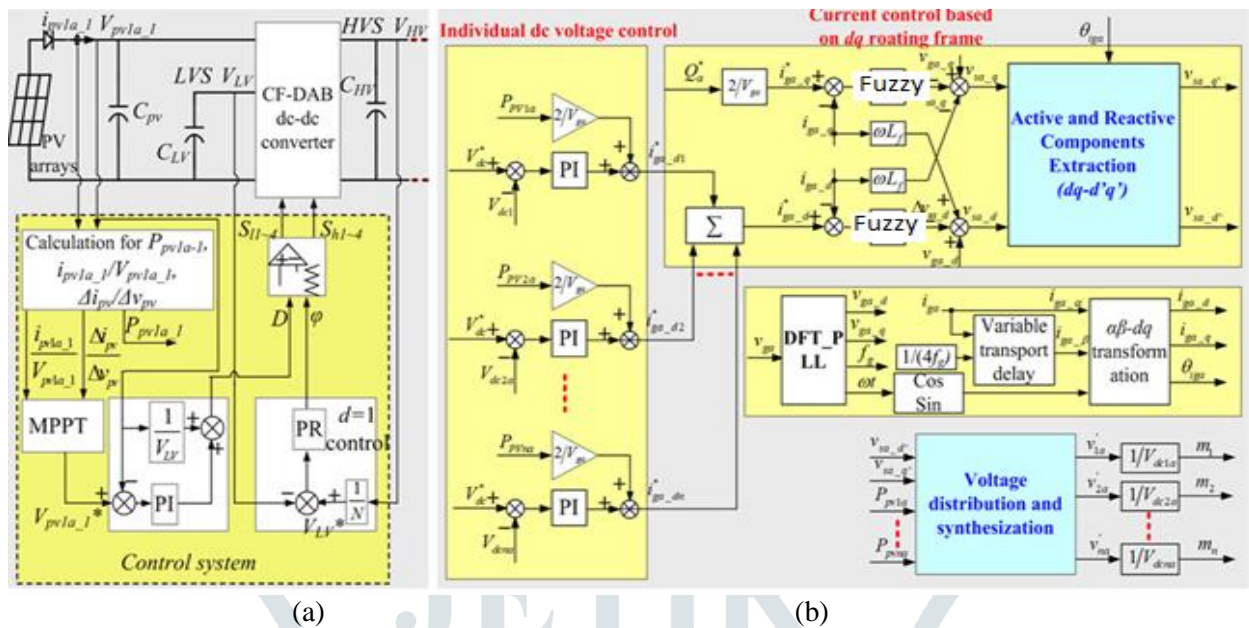

Fig. 3. Proposed control system of the grid-connected cascaded PV converters in phase a. (a) CF-DAB dc-dc converters control of one unit in module 1.(b) Cascaded multilevel inverters control.

**B. Cascaded Multilevel Inverter Control**

In the cascaded multilevel converter control showing in Fig. 3(b), active power distribution between cascaded PV converter modules is decided by the individual maximum power available from PV arrays. Considering dc capacitors connected with cascaded multilevel inverter modules have the same capacitance, reactive power from each module can be synchronously controlled to reduce the over modulation risk regardless of active power change. Therefore, the proposed control strategy can be called decoupled active and reactive power distribution control. The double-loop dq control based on discrete Fourier transform PLL method [8] is applied to achieve the active and reactive power distribution. The unique features of this control strategy is that active and reactive power is decoupled in each module by synchronizing with the grid current as described in Section II, which are not achieved in traditional control methods in [30] and [31]. Due to the same grid current goes through ac side of each module, only grid voltage synchronization is not able to perform the separation of active and reactive power in each module under unsymmetrical active power generation.

**C. Fuzzy Logic control Design**

Fuzzy logic is widely used in machine control. The term "fuzzy" refers to the fact that the logic involved can deal with concepts that cannot be expressed as the "true" or "false" but rather as "partially true". Although alternative approaches such as genetic algorithms and neural networks can perform just as well as fuzzy logic in many cases, fuzzy logic has the advantage that the solution to the problem can be cast in terms that human operators can understand, so that their experience can be

used in the design of the controller. This makes it easier to mechanize tasks that are already successfully performed by humans.

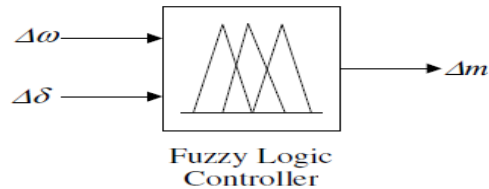

Fig:4. Fuzzy logic controller

Fig. 4 demonstrates the FLC structure. In this case, a two-input, one-output FLC is considered. The input signals are angular velocity deviation and load angle deviation and the resultant output signal is the amplitude modulation index inverter.

#### 4. SIMULATION VERIFICATION

The following simulation results provide the verification of the aforementioned analysis. Fig. 6 illustrates the system operation behaviors with traditional control strategy. As shown in Fig. 6(a), the solar irradiation for the four PV inverter modules increases from 200 to 1000 W/m<sup>2</sup> at 0.5 s. The active power to grid,  $P_{ga}$ , changes from 0.182 to 1 MW. The reactive power to grid,  $Q_{ga}$ , is controlled to be -0.5 MVAR. At 1 s, the solar irradiation on the third and fourth PV inverter modules decreases to 500 W/m<sup>2</sup>. Therefore, the active power from them,  $P_{out\ 3a}$  and  $P_{out\ 4a}$ , decreases from 0.25 to 0.12 MW. Accordingly, the reactive power from them,  $Q_{out\ 3a}$  and  $Q_{out\ 4a}$ , decreases from -0.125 MVAR to -0.085 MVAR. In this case, the unsymmetrical active power generation may result in the output voltage over modulation of the first and second inverter modules because they will be charged with the more voltage output to meet the system stability. On the other hand, the reactive power from the first and second PV inverter modules,  $Q_{out\ 1a}$  and  $Q_{out\ 2a}$ , increases from -0.125 MVAR to -0.165 MVAR to keep the  $Q_g$  to be constant. The increasing burden of reactive power generation exacerbates the output voltage over modulation from the first and second inverter modules resulting in serious grid current distortion as shown in Fig. 6(b).

The total harmonic distortion (THD) of grid current  $i_{ga}$  is 12.8%. After 1.5, the solar irradiation for the second-fourth PV inverter modules changes to 800, 600, and 500 W/m<sup>2</sup>, respectively. The reactive power changes along with the active power in the same direction. The grid current quality is still poor. The dc voltages on the four modules,  $V_{dc\ 1a}$  -  $V_{dc\ 4a}$ , have poor dynamic performance and deviate from the desired voltage.

Under the same conditions, the proposed control strategy can improve the system operation performance as shown in Fig. 7(a). The active and reactive power can be independently controlled.

Although the solar irradiation on first and second inverter modules is different from one on third and fourth inverter modules after 1 s, the reactive power from them is controlled to be symmetrical. By this proper reactive power distribution, the over modulation caused by the active power mismatch is eliminated. Even when different active power is generated from the four inverter modules after 1.5 s, the effective reactive power compensation can ensure the system with good power quality and stability as shown in Fig. 7(b). It can be seen that THD of  $i_{ga}$  is only 2.532%. The dc voltages on the four modules,  $V_{dc1a} - V_{dc4a}$ , have good dynamic performance and are controlled to vary with 20% rated voltage but do not affect power quality.

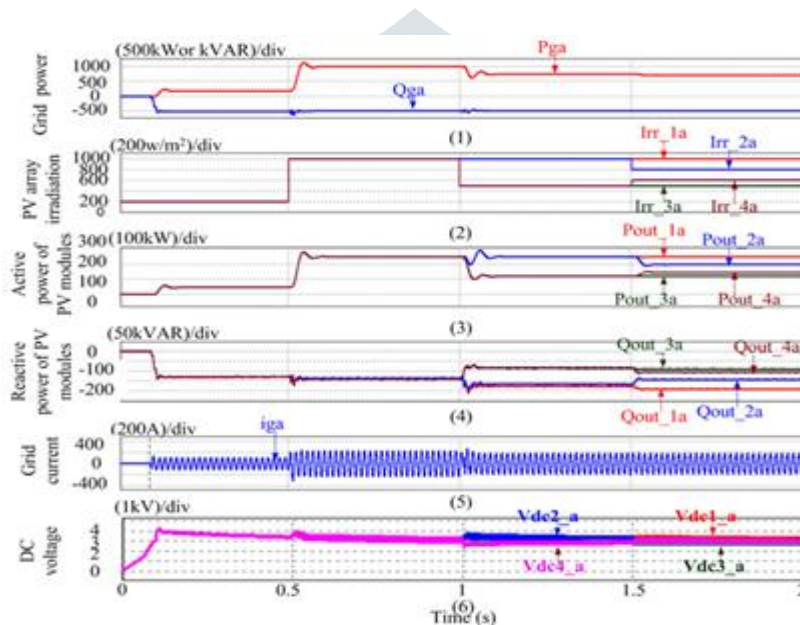

Fig. 6. Simulation results of PV system with traditional active and reactive power control in phase a. (a) Power distribution.

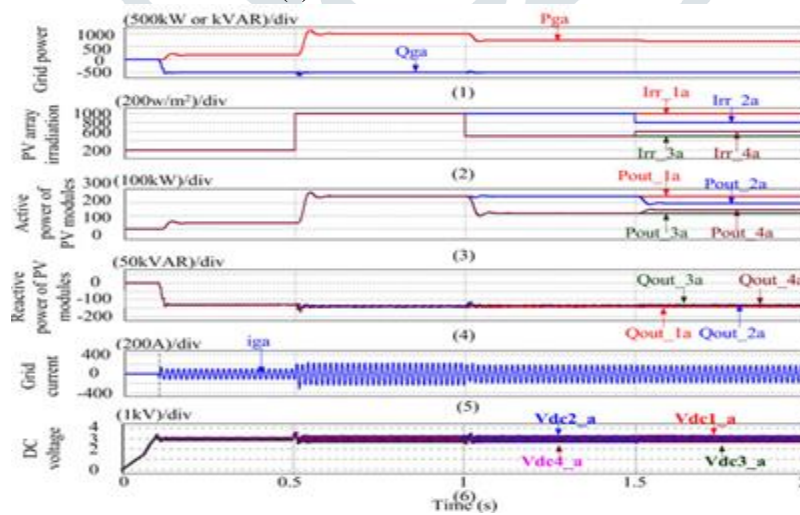

Fig:7. Simulation results of PV system with decoupled active and reactive power with fuzzy control in phase a. (a) Power distribution. (b) Zoomed waveforms at 1.5 s.



## V. CONCLUSION

This paper addressed the active and reactive power distribution among cascaded PV inverter modules and their impacts on power quality and system stability for the large-scale grid connected cascaded PV system. The output voltage for each module was separated based on grid current synchronization to achieve independent active and reactive power distribution. A decoupled active and reactive power with fuzzy logic control strategy was developed to enhance system operation performance. The proposed control strategy enabled the cascaded PV inverter modules to adequately embody their respective reactive power compensation capability regardless of their active power generation. Moreover, it was demonstrated that the risk of over modulation of the output voltage from the cascaded PV inverter modules can be effectively reduced, which improves system power quality and stability. Correspondingly, the simulation and experimental results confirmed the validity of the proposed control strategy.

## REFERENCES

- [1] Y. Bo, L. Wuhua, Z. Yi, and H. Xiangning, "Design and analysis of a grid connected photovoltaic power system," *IEEE Trans. Power Electron.*, vol. 25, no. 4, pp. 992–1000, Apr. 2010.
- [2] J. Ebrahimi, E. Babaei, and G. B. Gharehpetian, "A new topology of cascaded multilevel converters with reduced number of components for high-voltage applications," *IEEE Trans. Power Electron.*, vol. 26, no. 11, pp. 3109–3118, Nov. 2011.
- [3] L. Nousiainen and J. Puukko, "Photovoltaic generator as an input source for power electronic converters," *IEEE Trans. Power Electron.*, vol. 28, no. 6, pp. 3028–3037, Jun. 2013.
- [4] D. Meneses, F. Blaabjery, O. Garcia, and J. A. Cobos, "Review and comparison of step-up transformerless topologies for photovoltaic AC-module application," *IEEE Trans. Power Electron.*, vol. 28, no. 6, pp. 2649–2663, Jun. 2013.
- [5] S. Kjaer, J. Pedersen, and F. Blaabjerg, "A review of single-phase grid connected inverters for photovoltaic modules," *IEEE Trans. Ind. Appl.*, vol. 41, no. 5, pp. 1292–1306, Sep./Oct. 2005.
- [6] J. Mei, B. Xiao, K. Shen, L. M. Tolbert, and J. Y. Zheng, "Modular multilevel inverter with new modulation method and its application to photovoltaic grid-connected generator," *IEEE Trans. Power Electron.*, vol. 28, no. 11, pp. 5063–5073, Nov. 2013.
- [7] Y. Zhou, L. Liu, and H. Li, "A high performance photovoltaic module integrated converter (MIC) based on cascaded quasi-Z-source Inverters (qZSI) using eGaN FETs," *IEEE Trans. Power Electron.*, vol. 28, no. 6, pp. 2727–2738, Jun. 2013.
- [8] L. Liu, H. Li, and Y. Zhou, "A cascaded photovoltaic system integrating segmented energy storages with self-regulating power distribution control and wide range reactive power compensation," *IEEE Trans. Power Electron.*, vol. 26, no. 12, pp. 3545–3559, Dec. 2011.

- [9] Q. Li and P. Wolfs, "A review of the single phase photovoltaic module integrated converter topologies with three different DC link configurations," *IEEE Trans. Power Electron.*, vol. 23, no. 3, pp. 1320–1333, May 2008.
- [10] L. Zhang, K. Sun, Y. Xing, L. Feng, and H. Ge, "A modular grid-connected photovoltaic generation system based on DC bus," *IEEE Trans. Power Electron.*, vol. 26, no. 2, pp. 523–531, Feb. 2011.
- [11] L. M. Tolbert and F. Z. Peng, "Multilevel converters as a utility interface for renewable energy systems," in *Proc. IEEE Power Eng. Soc. Summer Meet.*, Seattle, Washington, USA, Jul. 2000, pp. 1271–1274.
- [12] M. Malinowski, K. Gopakumar, J. Rodriguez, and M. A. Perez, "A survey on cascaded multilevel inverters," *IEEE Trans. Ind. Electron.*, vol. 57, no. 7, pp. 2197–2206, Jul. 2010.
- [13] S. Harb and R. S. Balog, "Reliability of candidate photovoltaic module integrated- inverter (PV-MII) topologies—A usage model approach," *IEEE Trans. Power Electron.*, vol. 28, no. 6, pp. 3019–3027, Jun. 2013.
- [14] L. Liu, H. Li, and Y. Xue, "A coordinated active and reactive power control strategy for grid-connected cascaded photovoltaic (PV) system in high voltage high power applications," in *Proc. IEEE 28th Appl. Power Electron. Conf. Expo.*, Long Beach, CA, USA, Mar. 17–21, 2013, pp. 1301–1308.
- [15] P. Denholm and R. Margolis, "Very large-scale deployment of grid connected solar photovoltaics in the united states: Challenges and opportunities," in *Proc. Nat. Renewable Energy Laboratory Conf. Paper Preprint Solar*, U.S. Department of Energy, 2006.
- [16] M. Abolhassani, "Modular multipulse rectifier transformers in symmetrical cascaded H-bridge medium voltage drive," *IEEE Trans. Power Electron.*, vol. 27, no. 2, pp. 698–705, Feb. 2012.
- [17] K. Sano and M. Takasaki, "A transformerless D-STATCOM based on a multi voltage cascaded converter requiring no dc source," *IEEE Trans. Power Electron.*, vol. 27, no. 6, pp. 2783–2795, Jun. 2012.