

# “Design and Fabrication of a Manually Operated Hydraulic Press”

<sup>1</sup>Mr. Ram Wayzode, <sup>2</sup>Ms. Mayuri Dhoble, <sup>3</sup>Pranit Tajne, <sup>4</sup>Mohandas Balpande, <sup>5</sup>Aditya Pandey

<sup>1</sup>Assistant Professor Mechanical Engineering

<sup>#</sup>Students, Mechanical Engineering,

<sup>\*</sup>Suryodaya college of Engineering and Technology, Nagpur, India.

**Abstract—** The paper presents the development of a manually operated hydraulic press which encompasses the design, fabrication and performance evaluation of the press. The components parts of the machine were designed using various design equations. The design results were used to select materials for various components. The detailed drawing of the developed machine was done using Pro E software. In fabricating the machine, mild steel was used as the locally sourced material. The use of mild steel is due to the fact that its strength, rigidity and machinability falls within the design specifications. Some components of the machine developed include; the frame, cylinder mounting table, press pin, working table/bed, hydraulic tank, and hand lever. Some of the bought out parts include: ram assembly, pressure hose, pressure indicator and hydraulic pump. In evaluating the performance of the machine developed, mild steel plate of length 220 mm, breadth 70 mm and thickness 20 mm was put on the machine working table. This piece of material was bent after pressing the hand lever. The pressure at which bending took place was read to be 50 bar as indicated on the pressure gauge. The machine developed was also used to press a sleeve of internal diameter of 85 mm and external diameter of 89 mm into the cylinder of an engine block at a pressure of 15 bar. The cost of the machine as at the time of fabrication is N398,440.

**Keywords—** Design, Fabrication, Performance Evaluation, Hydraulic Press

## INTRODUCTION-

Presses are pressure exerting machine tools. They are used in industry for the cold working of metallic object into a variety of shapes through operations such as blanking, piercing, chawing, forming, bending and shearing. It represents an important part of manufacturing industry being used for cheap production of large quantities of components such as motor car bodies, electric motor parts and domestic electrical appliances parts. All presses consist of a machine frame supporting a bed, a ram, a source of power and a prime mechanism. Orthodox press may be hydraulic or pneumatic or may be mechanical crank presses. Hydraulic deals with the law governing the equilibrium and motion of fluid and their application to the solution of specific problems in various fields of engineering [1]. The hydraulic press is an invaluable

equipment in the workshop and laboratories especially for press fitting operations and for the deformation of materials such as in metal forming processes and material testing for strength [2]. A hydraulic press is a device using a hydraulic cylinder to generate a compressive force. It uses the hydraulic equivalent of a mechanical lever, and was also known as a Bramah press after the inventor, Joseph Bramah of England [3]. He invented and was issued a patent on this press in 1795. As Bramah (who is also known for his development of the flush toilet) installed toilets, he studied the existing literature on the motion of fluids and put this knowledge into the development of the press [4]. Hydraulic presses are preferred when very large nominal force is required [5]. Presses can be classified into three major categories as: hydraulic presses which operate on the principles of hydrostatic pressure, mechanical presses which utilize kinematic linkage of elements to transmit power and screw presses which use power screws to transmit power [6]. The development of engineering over the years has been the study of finding ever more efficient and convenient means of pushing and pulling, rotating, thrusting and controlling load, ranging from a few kilograms to thousands of tons. Presses are widely used to achieve this [2]. Several researches have been carried out on the design and fabrication of presses. [2] designed, constructed and tested a 30-ton hydraulic press using locally sourced materials. The principal parameters of the design included the maximum load (300 kN), the distance the load resistance has to move (piston stroke, 150 mm), the system pressure, the cylinder area and the volume flow rate of the working fluid. [7] researched on Structural Optimization of 5 Ton Hydraulic Press and Scrap Baling Press for Cost Reduction by Topology. Topology optimization was applied on various components of scrap baling press and 5 Ton hydraulic press using ANSYS WORKBENCH software. Suitable loads and constraints were applied on the initial design space of the components. An integrated approach was also developed to verify the structural performance by using ANSYS software. At the end, shape optimized design model was compared with the actual part that F. Adesina et al. DOI: 10.4236/oalib.1104522 3 Open Access Library Journal was being manufactured for the press. It was inferred that topology

optimization results in a better and innovative product design. [8] designed and fabricated a Hydraulic Press for the Production of Kiln Shelves. The design and fabrication of the machine was done according to laid down engineering and industrial design procedures ethics and codes. [9] [10] worked on the Analysis and Structural Optimization of 5 Ton H-Frame Hydraulic Press. The report opined that using the optimum resources possible in designing the hydraulic presses frame can effect reduction in the cost of the hydraulic presses by optimizing the weight of material utilized for building the structure. A critical look at mechanical workshops in Nigeria reveals that majority of press machines are imported into the country and this is done at high cost. Hence, it is expedient that more of such important machine be developed locally [2]. This work therefore presents the development of manually operated hydraulic press, which is of low cost, hydraulically operated and can compete favourably with imported press machines of the same designed capacity. The development of more of this machine will help to minimize high cost of purchasing and importation of this machine thereby strengthen our local manufacturing industries.

**LITERATURE REVIEW**

Using the optimum resources possible in designing the hydraulic press components can effect reduction in the cost by optimizing the weight of material utilized for building the structure. An attempt has been made in this direction to reduce the volume of material, cost of the press and to make it portable. Ertl et al. presented a 2D nonlinear magneto-mechanical analysis of an electromagnetic actuator based on finiteelements. The presented method enables the simulation of the complete switching cycle off a switching, short stroke solenoid actuators with sufficient accuracy. This could be achieved by considering nonlinear magnetics, eddycurrent induction and a physical correct implementation of the contact mechanics, which are relevant forthe complex dynamics of this valve types. Combining the concepts of pre-magnetization as well as over excitation to optimize the actuator dynamics, the pure valve needle flight time at valve opening can be reduced to 200ms. Thedeveloped numerical tools enable a systematic study of several methods to optimize the dynamics. Pohletal. presented a model of a fast 2/2 switching valve where both the magnetic pathas well as the spool assembly are modeled. The model also includes a description of the hysteresis characteristics of the magnetic path. An optimization strategy has been utilized in order to parameterize the model against measured data. However, even for major deviations from the operational point used for the model adaptation, the model predicts the valve response sufficiently accurately. The switching cycle was less than 10 ms.

**II. MACHINE FABRICATION PROCESSES**

The various processes used in the fabrication of this hydraulic press machine include: Measurement, Marking out, Cutting, Drilling, Welding, Fastening, Grinding and Painting. Assembly and Welding of Machine Components In welding various components of this machine together, electric arc welding technique was used because of the ease of concentration of heat. Heat spread reduces buckling and warping. The heat concentration also increases the depth of penetration and speeds up the welding operation. The base

which is made of U Channel mild steel was first set up. The base has a length of 840 mm, breadth of 180 mm and thickness of 6 mm. The column which is made of four pieces of vertical flat mild steel plate was welded to the base that has been set up. Each of the plate has length of 1650 mm (vertical height), breadth of 102 mm and thickness of 20 mm. They were all welded to the base to form the column of the machine. Having done this, two pieces of flat mild steel plate (length of 840 mm, breadth of 225 mm and thickness of 16 mm) were welded to the top part of the frame. With all the major frame parts in firm position, the frame stand was welded to the base of the frame to provide for stability of the machine during operations. Three holes of 50 mm in diameter was made on each of the column. This is to give room for adjustment of the bed (table). Also, a rectangular oil tank of (203.2 × 203.2 × 209.5) mm was fabricated and welded to the centre part of the column

Table 1. Some designed values for the hydraulic press

S/R	Design Factor	Design Values
1	Volume of Hydraulic tank	0.00867 m3
2	Core diameter, dc	7 mm
3	External load acting on bolt and nut	28.3 KN
4	Initial tension in a bolt, Pi	14.5 N
5	Stress area	7.28 × 10 <sup>-6</sup> m2
6	Weight of piston, Wp	42.4 N
7	Weight of Cylinder, Wc	150 N
8	Velocity of flow of fluid, Vf	4.22 m/s
9	Oil flow rate, Q	0.00133 m3 /s
10	Hydraulic Power, Ph	10.8 W

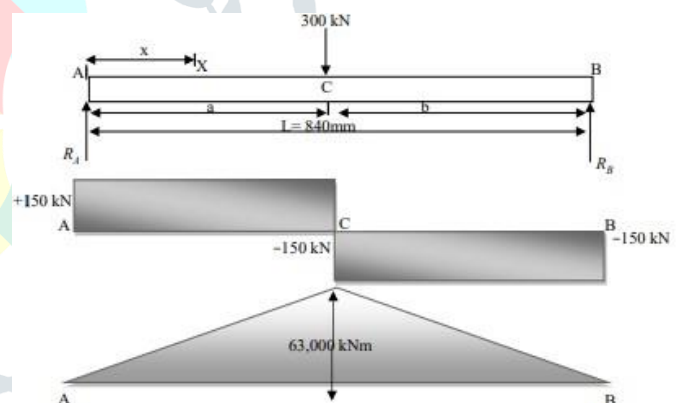

Figure 1. Shear force and bending moment diagrams for a simply supported beam with a point load of 300 kN.

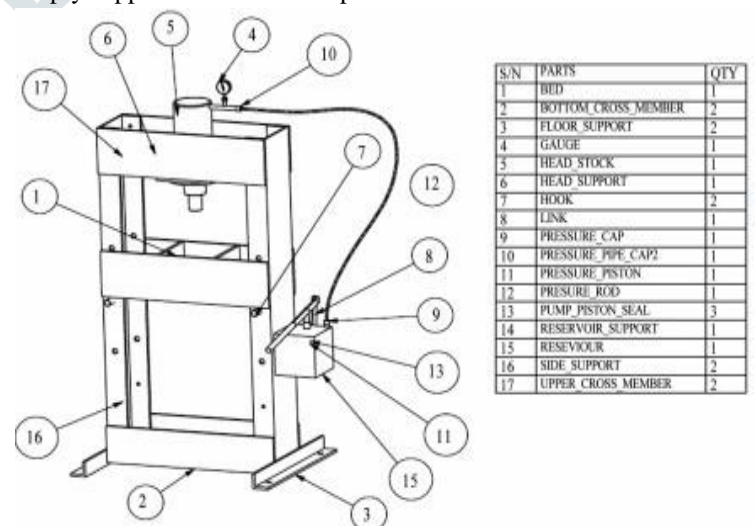

Figure 2. Isometric drawing of the machine and part list.

of the machine frame. This tank serves as oil reservoir needed to pump the hydraulic pump. A hand operated lever which is made of mild steel rod of 610 mm length and 25 mm thickness was connected to oil tank with the aid of a pivot. SAERI2 Pressure hose was fitted to the hydraulic oil tank in order to convey hydraulic oil from the tank to a single acting hydraulic pump which is mounted on the top part of the frame. The hydraulic pump has a load capacity of 30 tons. All the machine parts were firmly secured to ensure rigidity and support. The finishing of the fabricated machine involves grinding the welded joints and painting with emulsion paint

### III. METHODOLOGY

In achieving the aim of this work, component parts of the machine were designed using various design equations. The design results were used to select materials for various components. The detailed drawing of the developed hydraulic press machine was done using Pro E software. In fabricating the machine, mild steel was used as the locally sourced material. The use of mild steel is due to the fact that its strength, rigidity and machinability falls within the design specifications. It is also available and cost effective.

#### Design Analysis of Some Machine Components

Some components parts of the machine developed include; the frame (stand, base support, column, top plate), cylinder mounting table, press pin, working table/bed, cylinder/ram assembly, hydraulic tank, hand lever, pressure hose, pressure indicator and hydraulic pump.

#### Machine Frame

A frame is a structure on which main units of a machine tool are assembled. For this work, the frame was designed to accommodate ram assembly, hydraulic pump, oil tank, and working table (bed). The design consideration is that of direct tension imposed on the pillars. Other frame members are subjected to simple bending stresses.

#### Determination of Volume of Hydraulic Tank

The volume of hydraulic tank was calculated from the Equation (1);

$$V = LWH$$

where L is the length of the tank in metres, W is the Width of the tank in metres, H is the height of the tank in metres.

### Results and Discussion

The developed manually operated hydraulic press was achieved by following the stated objectives of this work. The machine developed was made from locally sourced materials. Mild steel was used in fabricating majority of the components of the machine. One important feature of this press machine is interchangeability of mould and die without dismantling the ram assembly. The machine developed is shown in Figure 3. Figure 4(a) Shows cylinder engine block before pressing sleeve into it while Figure 4(b) shows cylinder engine block after pressing of sleeve using the developed press machine. Bending of 20 mm Steel Plate is presented in Figure 5(a) while Figure 5(b) shows the demonstration of plate folding. Figure 6(a) shows a Punch, Die and steel plate before bending while Figure 6(b) show the folded plate. Prior to machine performance evaluation, machine frame, structural members, weld, pump and cylinder mechanism were inspected in order to check for any fault or leakages of hydraulic oil. Tests were carried out on the multipurpose press machine by using it to

press different metals (materials) at maximum pressure. The hydraulic press machine developed was used to perform various press works. The machine worked without any challenge as there was no distortion, deformation, no weld failure, no leakages and the operation of hydraulic pump, ram and pump mechanism was quite satisfactory under the varying loads. In evaluating the performance of the machine developed, mild steel plate of length 220 mm, breadth 70 mm and thickness 20 mm was put on the machine working table. This piece of material was bent after pressing the hand lever. The pressure at which bending took place was read to be 50 bar as indicated on the pressure gauge. Also, a 3 mm steel plate of 290 mm × 225 mm was placed on the machine working table (bed) to be bent. It was noted that bending of this plate started at a pressure of 15 bar and maximum bending was taken to be 20 bar. The machine developed was also used to press a sleeve of internal diameter of 85 mm and external diameter of 89 mm into the cylinder of an engine block at a pressure of 15 bar. Other press operations which the machine could perform include but not limited to deep drawing, cup drawing, shallow drawing and stamping.



Figure 3. The fabricated hydraulic press machine.



Figure 4. (a) Cylinder engine block before pressing sleeve; (b) Cylinder engine block after the pressing of sleeve.

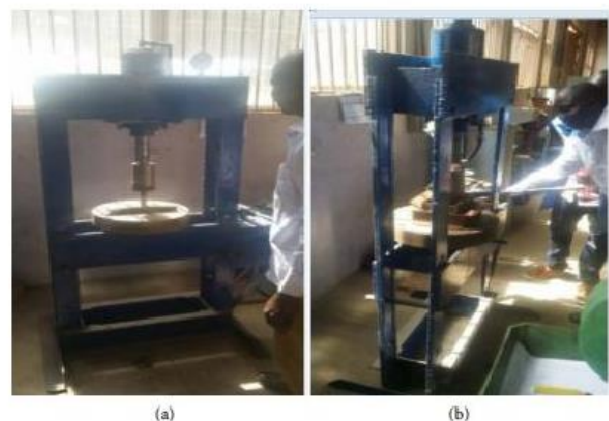

Figure 5. (a) Bending of 20 mm steel plate; (b) Plate folding.



**Figure 6.** (a) Steel plate before bending, punch and die; (b) The folded plate.

## Conclusion

A hydraulic press machine has been developed. The machine was fabricated using locally made materials. The machine is capable of performing various press works. Various machine parts such as pump, hand lever, ram assembly and pressure gauge worked effectively and efficiently. Some of press work operations performed on the machine include: bending, punching, drawing and stamping. The machine was also used to press sleeves of internal diameter of 85 mm and external diameter of 89 mm into the cylinder of an automobile engine block at a pressure of 15 bar. Performance evaluation of the machine shows that it can compete favourably with imported press machines of the same designed capacity. The cost of developing the machine locally as at the time of fabrication was N398,440 (\$2000) compared to the cost of purchasing the imported ones of same capacity which ranges from \$5000 to \$15,000 excluding cost of importation. The development of more of this important workshop machine is expected to boost our local manufacturing industries.

## Acknowledgements

The Authors would like to acknowledge Bukola Adesina who contributed immensely to the success of this work. We declare that no funding was received from any source as financial support for this research

## References

- [1] Jain, R.K. (2012) Production Technology. 17th Edition, Khanna Publishers, New Delhi, 806-824.
- [2] Sumaila, M. and Ibadode, A.O.A. (2011) Design and Manufacture of a 30-Ton Hydraulic Press. Assumption University Journal of Technology, 14, 196-200.
- [3] Parker, D.T. (2013) Building Victory: Aircraft Manufacturing in the Los Angeles Area in World War II. Cypress, Canada, 20-87.
- [4] Carlisle, R. (2004) Scientific American Inventions and Discoveries. John Wiley & Sons, Inc., New Jersey, 266.
- [5] Lange, K. (1975) Handbook of Metal Forming. McGraw-Hill, New York.
- [6] Sharma, P.C. (2005) A Textbook of Production Engineering, 10th Edition, S. Chard and Company Ltd, New Delhi, 69-146.
- [7] Muni, P. and Amarnath V. (2011) Structural Optimization of 5 Ton Hydraulic Press and Scrap Baling Press for Cost Reduction by Topology. International Journal of Modeling and Optimization, 3, 185-190.

[8] Ayodele, O.D., Ahuwan, A. M., Sullayman, U.A.A. and Yawas, D.S. (2005) Design and Fabrication of a Hydraulic Press for the Production of Kiln Shelves. Journal of Chemical, Mechanical and Engineering Practice, 3, 26-36.

[9] Santoshkumar, S.M., Yogita N.P. and Mattikalli, A.C. (2014) Analysis and Structural Optimization of 5 Ton H-Frame Hydraulic Press. International Journal of Innovative Science, Engineering and Technology, 5, 356-360.

[10] Sharma, P.C. (2005) A Textbook of Production Engineering. 10th Edition, S. Chard and Company Ltd, New Delhi, 69-146.

