

# Learning from the Past: Study on Sustainable Features from Vernacular Architecture in Coastal Karnataka.

<sup>1</sup>Vikas.S.P, <sup>2</sup>Sagar.V.G, <sup>3</sup>Manoj Kumar.G, <sup>4</sup>Neeraja Jayan

<sup>1</sup>Student, 6<sup>th</sup> sem, School of Architecture, REVA UNIVERSITY,

<sup>2</sup>Student, 6<sup>th</sup> sem, School of Architecture, REVA UNIVERSITY,

<sup>3</sup>Student, 6<sup>th</sup> sem, School of Architecture, REVA UNIVERSITY,

<sup>4</sup>Associate Professor, School of Architecture, REVA UNIVERSITY.

*Abstract:* Vernacular architecture can be defined as that architecture characterized based on the function, construction materials and traditional knowledge specific and unique to its location. It is indigenous to a specific time and place and also incorporates the skills and expertise of local builders.

The paper is elaborated on the basis of case studies of settlements in the Coastal region of Karnataka with special reference to Barkur and Brahmavar of Udupi regions. It has evolved over generations with the available building materials, climatic conditions and local craftsmanship. However, some examples of vernacular architecture are still found in Barkur and Brahmavar. These vernacular residential dwellings provided with various passive solar techniques including natural cooling systems and are more comfortable compared to the contemporary buildings in today's context.

This research paper into various parameters which defines the vernacular architecture of coastal Karnataka and how these parameters can be interpreted in today's context so that it can be used effectively in the future residential designs.

**keywords - sustainable, vernacular architecture, modern building, sustainability.**

## I. INTRODUCTION

Udupi is a city in the southwest Indian state of Karnataka and is known for its Hindu temples, including the 13<sup>th</sup> century Krishna temple which houses the statue of lord Krishna. Karnataka witnesses three types of climate. The state has a dynamic and erratic weather that changes from place to place within its territory. Due to its varying geographic and physio-graphic conditions, Karnataka experiences climatic variations that range from arid to semi-arid in the plateau region, sub-humid to humid tropical in the Western Ghats and humid tropical monsoon in the coastal plains. The coastal Karnataka region stretches over the districts of Udupi, Uttara Kannada and Dakshina Kannada.

Brahmavar, a village in the north of Udupi, Karnataka. it is settled on the banks of a river Suvarna And Seetha. It is 68 kilometer north of Mangalore and 13 kilometer north of Udupi on national highway 66. River Suvarna and sita flow around Brahmavar, these rivers originated from the Western Ghats and forms back waters around Brahmavar before joining the Arabian Sea. Brahmavar is surrounded by many villages such as Hamdani, Baikady, Matpadi and Barkur. The place got its name from the term Brahma's vara.

The study is directed towards understanding of vernacular architecture in the coastal belt of Karnataka with reference to socio culture, planning, architectural characteristics, climate, material available and construction techniques.

Barkur was established as a town centre much before 8<sup>th</sup> – 9<sup>th</sup> century and it was an administration centre in 12<sup>th</sup> century. It reached its peak as an important trade centre of Vijayanagara dynasty between 14<sup>th</sup> – 16<sup>th</sup> century however after tippu's invasion in 17<sup>th</sup> century and during the British empire from 18<sup>th</sup> – 19<sup>th</sup> century the status of Barkur went down.

Local Culture and Heritage: Bhuta Kola, Aati kalenja, and Nagaradhane are some cultural traditions of Udupi. The residents celebrate festivals such as Makara Sankranti, Krishna Janmashtami, Navaratri, Deepavali, Eid al- Adha, Eid al-Fitr and Christmas. Folk arts like Yakshagana are also popular.

## II. BACKGROUND

The background of the study is to learn the style adapted in the northern region of Karnataka with relevance to architecture. The study is directed towards understanding of vernacular architecture in the coastal belt of Karnataka with reference to socio-culture, planning, architectural characteristics, climate, material available and construction techniques.

The roofs were made to keep the house cool and temperate. The walls were thick and insulating to the heat on the outside. The windows were small and enough to ventilate the interiors whereas they ensured the interiors didn't heat up. All of these features in a house were built keeping in mind the climatic conditions of the region which is an important inference.

Locally available materials like wood, bamboo and stone were used to build all the spaces necessary. We understood the requirements of people of various origins and also their preferences in improvements. Tapping into the traditional vernacular style of architecture of any Indian village is like learning architecture from the beginning with a whole new perspective.

## III. NEED FOR STUDY

The documentation of Brahmavar, a rural settlement was to obtain real-life experience of the still existing vernacular architecture exclusive to the Northern Karnataka provinces. The motive of this rural study was to understand how vernacular architecture works in relation to the region, terrain, climate and the locally available materials while also keeping in mind the needs and whims of the clientele and use them in our projects to make our designs climate friendly, sustainable and also ensure the conservation of the vernacular style specific to that area.

## IV. AIM

To understand the vernacular architecture of Barkur and Brahmavar and propose guidelines to achieve sustainability in modern residential buildings.

## V. OBJECTIVES

1. To explore the various vernacular architecture styles of coastal regions in India.
2. To explore how climatic condition influences the planning of residential buildings in Barkur and Brahmavar.
3. To explore the various materials used for construction of residential buildings in Barkur and Brahmavar.
4. To propose Design strategies to achieve sustainability in modern residential buildings.

## VI. SCOPE

This study focuses through primary survey, analysis of climatic conditions of the region which influences the vernacular architecture and also the construction technology with materials through architectural documentation.

VII. METHODOLOGY

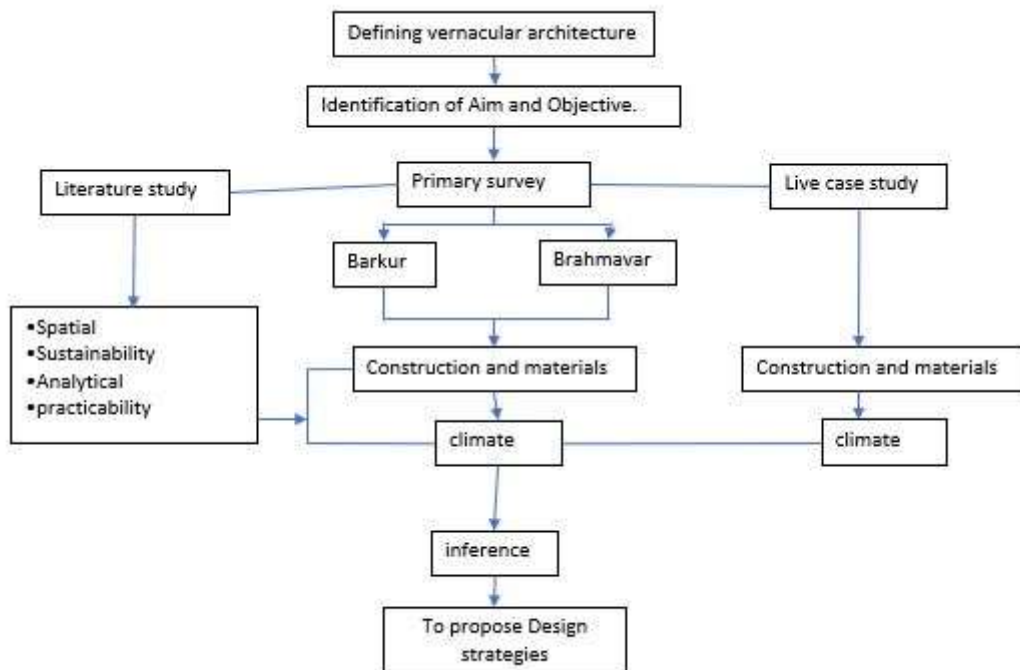

VIII. LITERATURE STUDY

8.1 The living culture and typo-morphology of Vernacular houses in Kerala.

This research paper is written by Indah Widiastuti, who is a Senior Lecturer at the School of Architecture, Planning and Policy development- SAPPD, at the School of Architecture Planning and Policy development Institute of Technology Bandung, Indonesia. This paper was published on 01 January 2014, which it was written on September, 2013. [ISVS e-journal, Vol. 2, no.4]

This paper mainly focuses on observations of traditional vernacular houses in Kerala using the frameworks of Typo Morphology and vernacular architecture and five general types of residential buildings with regard to structural, spatial arrangements and their nature of development. This study confirms the existence of an uninterrupted continuity between the architecture of South India and the Southeast Asia.

This article is written based on a chronicle of observations of traditional vernacular houses in Kerala region during 2004. The motive of the study is to observe the types of Indian architecture which share characteristics with the Southeast Asian Architecture. Popular urban houses follow as common as day-to-day folk’s residences available everywhere in rural and urban areas. They appear as free-form single house design rooted in single rectangular hall (I-shape) type. It is assumed that the local builders had been quite familiar with the local construction and the regional Vaastu shastra that influenced the design of these houses. The alignment of fenestrations always demonstrates continuous imaginary lines from the front room to the rear room and from one end to another end on in each bay and it is believed that there is a sacred imaginary axis line criss-crossing the building mass perpendicularly which must not be disrupted by any constructions. These free-construction sections are usually designed as opening and therefore constitute free flowing openings from rear to front façade and from one end to another end of the building.

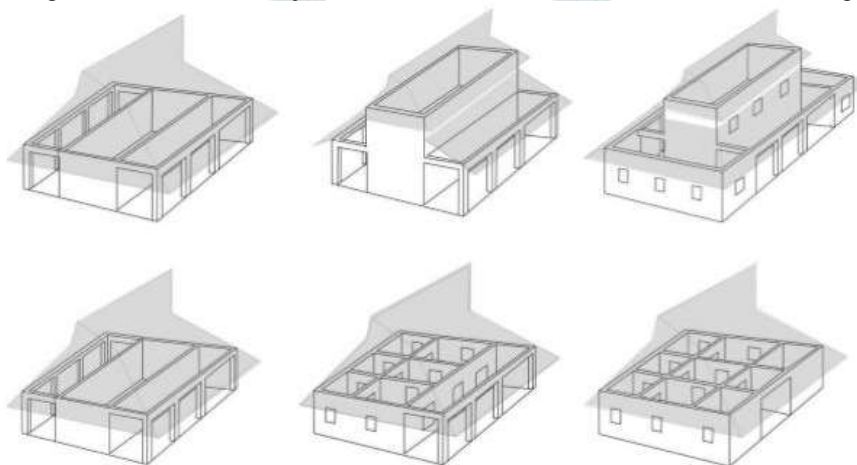

Fig 1. Types of Ekalasa with Alindam function as Veranda.  
Source: Indah widiastuti,2004

However, this observation is not meant to develop a rigorous comparative study or to argue about origin of the shared designs. Instead, it highlights the characteristics of the Kerala architecture that coincides with the architecture in Southeast Asia.

The result of this study on traditional-vernacular architecture of Kerala shows some typo-morphological characteristics that marked continuity of traditions between the Dravidian of South Indian and the Austronesian of the Southeast Asian architecture. Further studies of vernacular architecture of Kerala, South India and Southeast Asia would potentially lead to exploration of a common knowledge about ancient vernacular Asian architecture.

Source: Indah Widiastuti, School of Architecture, Planning and Policy development- SAPPD, Institute of Technology, Bandung (ITB), Indonesia, Journal of the International Society for the Study of Vernacular Settlements 41, The Living Culture and Typo-Morphology of Vernacular Houses in Kerala, ISVS e-journal, Vol. 2, no.4, September, 2013.

### 8.2 A study on Sustainable design principles: a case study of a Vernacular dwelling in Thanjavur region of Tamil nadu, India.

This research paper is written by the lecturers (Department of Architecture) Periyar Maniammai University, Thanjavur. It was published on October 2014 in Indian Journal of Traditional knowledge of vol. 13 (14).

It follows the parameters such as geographical location, climatic conditions, occupation, culture and tradition of the society/community decide these principles in a specific set up and make the structures sustainable in all respect.

Its research methodology is aimed at exploring the generic sustainable principles in vernacular architecture of Thanjavur region of Tamil Nadu, India by selecting, documenting and analysing a case study example in one of the traditional settlements in the Vallum settlement region.

This study tells and analysis of the vernacular architectural principles is not just to copy them in the present context but to have a better understanding of the environment, life style, tradition and culture of the society and their influence on the built forms. So, it is concluded that the architectural built forms of the vernacular settlements have evolved in response to the climate, life style and availability of the materials and techniques specific to that region which ultimately lead to sustainability.

This paper states that its planning aspects in terms of its plan, elevation, section, form and other architectural details of the structure. The materials used and the techniques adopted may be expensive and time consuming in present condition but the context and relevance of these aspects in satisfying the users need is highly appreciable and the essence of these need to be explored in modern context.

Source: Indian Journal of Traditional Knowledge, A study on sustainable design principles: A case study of a vernacular dwelling in Thanjavur region of Tamil Nadu, India. Vol. 13 (4), October 2014, pp. 762-770.

### 8.3 Design Strategies for Contemporary Coastal Architecture.

Vernacular architecture of Indian coastal region has been enriched for several centuries. Several different vernacular architectures lie in the nine states having different languages and culture. So does the architecture of these area is different but there is one common thing in them is that they have survived for so long while kept maintaining the functional efficiency, beauty, structural strength, cost effective use of local material.

Which is providing various techniques and methods which can be incorporated in modern architecture in order to achieve sustainability, energy efficiency and cultural values to our contemporary Indian coastal architecture? This research paper is all about Innovative ways to incorporate various coastal vernacular techniques in order to achieve sustainability in the modern coastal architecture.

Source: Rajeev Parashar and Sudheer Singh Sikarwar, Design Strategies for Contemporary Coastal Architecture, December 2017, IJIRT, Volume 4 Issue 7, ISSN: 2349-6002

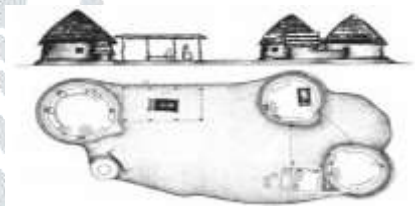

Fig 2. Bhonga hut



Fig 3. Kerala vernacular housing

### 8.4 The Vernacular Architecture of Kerala, South India: An Architecture Knowledge on The Crossroad Between Southeast Asia And South Asia.

The vernacular architecture of Kerala in India is explored to demonstrate an architecture with Southeast Asian characters but situated beyond the agreed (modern) region of Southeast Asia. The elaborations are mainly based on ethnographic studies and observations, done between Southeast Asia.

The vernacular architecture of Kerala reflects a combination of Indic and Southeast Asian characters. The Indic characters are reflected in the domination of massive characters of the earthen material construction and the main practice of Vedic dwelling culture as reflected in observance to Vaastu treatise in house design.

This study would try to suggest a model of knowledge which principally suggests that for the case of Southeast Asia, with its unique cultural dynamic and multiplicity, it is more important to explore the processes of becoming that lend base to the emergence of the people, its habitations and architectural traditions, rather than examining the architecture within a given fixed territory. This model is tentatively addressed as the pre-modern vernacular architecture in the crossroad between Western Coast of India and the West Southeast Asia.



Fig 4. Comparison of Saddle-Hipped Roof of House in Kottayam District, Kerala, India and Batak Karo,

Source: 1stseaarc symposium, nus, 8-9 January 2015, Indah widiastuti, the vernacular architecture of Kerala, south India: an architecture knowledge on the cross-road between southeast Asia and south Asia.

**8.5 Vernacular architecture: questions of comfort and practicability.**

A paradoxical situation exists where vernacular building traditions are in a state of decline and are being replaced by modern counterparts, but they are repeatedly cited in the academic literature as exemplary models of environmental practice. This paradox is examined through research on whether vernacular passive cooling systems in the hot and dry climates of present-day Iran are practicable for the provision of comfortable indoor temperatures. Investigating their technical thermal performance as well as user perceptions and behavior, positive and negative attributes of the cooling systems are identified.

If conclusions about the long-term viability of vernacular buildings are to be drawn, then social, cultural, economic and environmental attributes need to be taken into consideration. Despite rather widespread and persistent assumptions, vernacular building traditions are not necessarily able to survive and the choices made by local people regarding the continuation or abandonment of specific traditions are influenced by a variety of cultural and practical factors.

This substantiates the necessity of an integrated and holistic approach that engages with these variables in order to acquire a better understanding of the conditions for the survival of vernacular traditions.

Source: Foruzanmehr, Ahmadrza, and Marcel Vellinga. "Vernacular architecture: questions of comfort and practicability." Building Research & Information 39.3 (2011): 274-285.

**8.6 South Indian Vernacular Architecture - An Executive Summary.**

Vernacular Architecture is increasingly becoming a subject of major interest not only to architecture theorists, but also to designers and technologists for very many good reasons. It has now become very apparent, that although technological advancement brings modern civilization to our communities, it also accelerates the disappearance not only the style of life which has been developed over a span of many centuries, but also the very veins of cultural identity which are so vital for the survival of any society.

The onslaught of modern technology has robbed our communities of the construction skills and environmentally sensitive design of their dwellings. "Modern Architecture" is becoming more and more environmentally unfriendly not only to people, but also to the surrounding natural environment, including the excessive use of energy in cooling buildings.

That is why we have to revert back to vernacular architecture to see how we can salvage the vernacular principles and use them in sustainable architecture. There has been a turn around after years of environmentally unfriendly materials and bad architecture to sustainable building materials and construction methods.

Source: DOI: 10. 21276.iajmr.2016.2.4.1, Asian Journal of Multidisciplinary Research (IAJMR), ISSN: 2454-1370, vol. 2, issue – 4 ,2016.

SL NO.	AUTHOR (YEAR)	TYPE OF STUDY	AREA OF STUDY	PARAMETERS	INFERENCES
1.	Indah widiastuti (2013)	Spatial	Kerala.	<ul style="list-style-type: none"> <li>• Structural</li> <li>• Plan</li> <li>• Courtyard</li> <li>• Veranda</li> </ul>	<ul style="list-style-type: none"> <li>• Frameworks of typo-morphology with regard to structural, spatial arrangements and their nature of development.</li> </ul>

2.	P. Jayasudha, M. Dhanashekar, Monsigh D devadas, N. Ramachandran (2014)	Sustainability	Thanjavur, Tamil nadu.	<ul style="list-style-type: none"> <li>• Settlements</li> <li>• Plan, elevation, section and form.</li> <li>• Context</li> <li>• Climate</li> </ul>	<ul style="list-style-type: none"> <li>• Traditional architectural principles always respected nature, and was climate conscious, user-friendly, reflected the culture and tradition of the community at large and most important was contextual.</li> </ul>
3.	Sudheer singh sikarwar, Rajeev parashar (2017)	Analytical	Coastal areas of India.	<ul style="list-style-type: none"> <li>• Study on various selected regions around India.</li> <li>• The analysis on various houses on each coastal region</li> <li>• Materials</li> <li>• Shape of house in planning</li> <li>• Exterior space</li> <li>• Climatic analysis</li> <li>• Doors, windows and joinery details</li> <li>• Comparative analysis on various region material</li> </ul>	<ul style="list-style-type: none"> <li>• Climatic analysis.</li> <li>• Exterior space.</li> <li>• Doors and analysis of materials.</li> <li>• Analysis of various region materials uses.</li> </ul>
4.	Indah widiastruti (2015)	Analytical	Kerala.	<ul style="list-style-type: none"> <li>• Convergence and divergence on building typology</li> <li>• Spatial organization</li> <li>• Characters and culture</li> <li>• Similarities in both regions (analysis)</li> <li>• Analysis on roofing, planning and construction elements in both the regions and concluding by three parameters above.</li> </ul>	<ul style="list-style-type: none"> <li>• Vaastu mandala towards the planning.</li> <li>• Pre-modern strategies for future.</li> <li>• Material usage in construction.</li> </ul>
5.	Foruzanmehr, Ahmadreza, Marcel Vellinga. (2011)	Practicability	Middle east region.	<ul style="list-style-type: none"> <li>• Vernacular architecture is more of a study rather than being practical</li> <li>• Mechanical methods have taken over passive methods/strategies.</li> <li>• E.g: air conditioners have taken over use of wind catchers.</li> </ul>	<ul style="list-style-type: none"> <li>• Passive design technologies in vernacular architecture can be adopted for modern designs.</li> </ul>
6.	P. Satheesh kumar, C. Sivasubramanian M. Jeganathan, J. Ashok. (2016)	Evolutionary	South India.	<ul style="list-style-type: none"> <li>• The change in vernacular architecture from hut to present vernacular building.</li> <li>• The change in culture and architecture reciprocal.</li> <li>• India's cultural heritage is vanishing due</li> </ul>	<ul style="list-style-type: none"> <li>• Future style of life through vernacular architecture.</li> <li>• Transition of present to future.</li> </ul>

				to the influence of urbanization and change in culture (way of living).	
--	--	--	--	---	--

**IX. PRIMARY STUDY**

**9.1 UPADHYAYA THOTTI MANE**

This is a residential building located at Bramhavar, Udipi. This house was built during British period nearly 100 years ago. It is mainly in rectangular plan 18.2m x 16.2m of G + 1 structure. This house was built using mud, bricks, jaggery, grass and lime was used as plastering material. In this residential typology, the timber is used for Doors, columns and beams. There are 3 rooms (3x7.5m ,4.7x4.6m ,2.9x2.8m) few rooms do not have windows, they do not have proper ventilation or lighting. There are 3 rooms (3x7.5m ,4.7x4.6m ,2.9x2.8m) few rooms do not have windows, they do not have proper ventilation or lighting. The entry is towards the North as the portico and towards West there is veranda. It is known that; this house was used as a British guest house and now it is not in use.



Fig.5 Street view at entrance of the Upadhyaya house.



Fig.6 View of the Upadhyaya house

Source: Documentation study of Barkur and Brahmvavar, by the students of IV sem B. Arch, 2017-2022 batch.

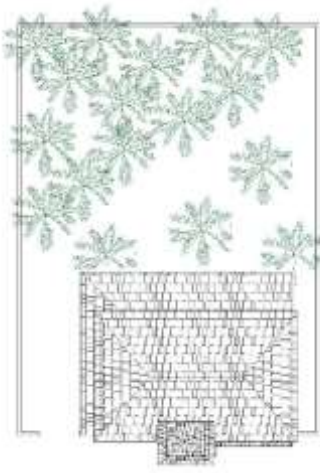

Fig.7 Site plan

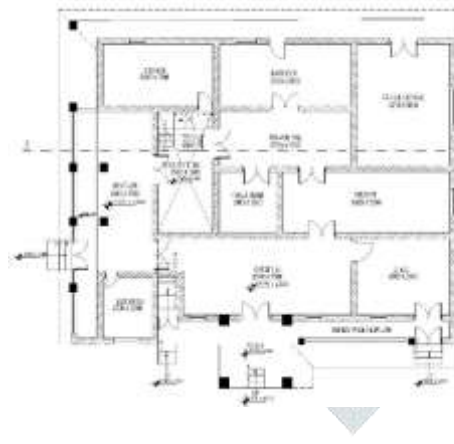

Fig.8 Ground floor plan

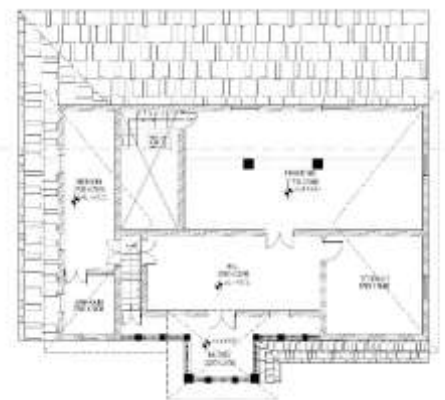

Fig.9 First floor plan

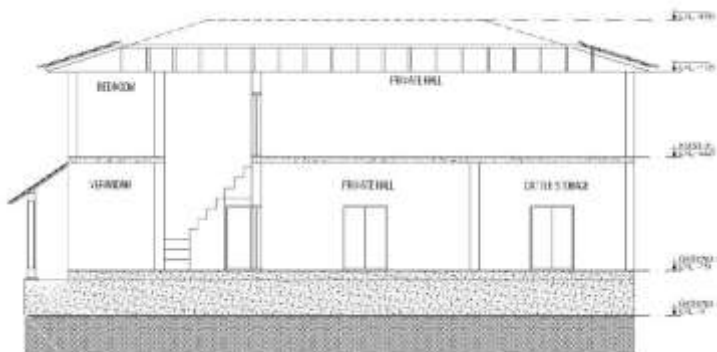

Fig.10 Section

Source: Documentation study of Barkur and Brahmavar, by the students of IV sem B. Arch, 2017-2022 batch.

**9.1.1 Construction details**

**9.1.1.1 Columns**

In this residential typology, only timber columns were used. During olden days, timber easily available and also it is a locally available material in this region and it is easy to carve. This column also supports the climatic conditions.

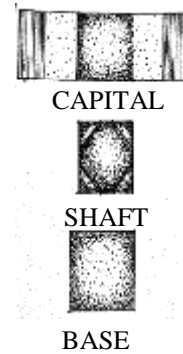

Fig.11 Plans of column

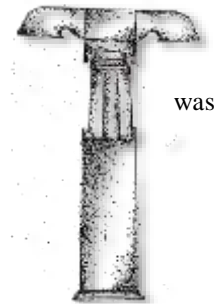

Fig.12 Timber column at Upadhyaya house

**9.1.1.2 Doors**

Timber doors are used in this typology with lot of floral patterns on it with less carved sculptures on it, thus it gives an aesthetic appeal in front elevation.



Fig.13 Timber door at Upadhyaya house

Source: Documentation study of Barkur and Brahmavar, by the students of IV sem B. Arch, 2017-2022 batch.

**9.1.1.3 External walls**

In this wall section, the main materials used are mangalore tiles for roofing, bricks, lime, jaggery for wall and for lintels, doors and roofing frame timber was used. Mangalore tiles were inspired from the vernacular architecture in Kerala, which also has the similar climatic conditions.

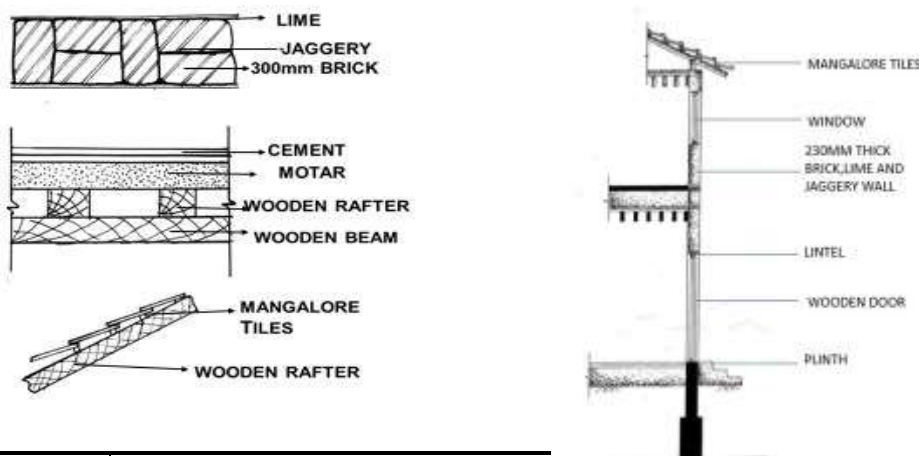



Fig.14 External wall section of Upadhyaya house

Source: Documentation study of Barkur and Brahmavar, by the students of IV sem B. Arch, 2017-2022 batch.

9.1.2 Material used

Table.1 showing the material usage in Upadhyaya house

WALL	Use of burnt clay brick of thickness 300mm, Jaggery as binding material, lime used for Plastering and some grasses were used in Wall.
FLOOR AND SLAB	It is a cement flooring, the slab contained wood, [bogha and kirala] and cement flooring.
ROOF	It is a bonnet roof with angle of 15 degree. This roof was composed of Mangalore tiles on timber frame.
OPENINGS	Wooden panel.
STRUCTURE	Load bearing walls and wooden frame.

9.1.3 Climatic

It is known that falls in tropical driest month is mm of rainfall. In peak, with an mm. The warmest year is April temperature of °C on average, coldest month of

9.1.3.1 Wind direction

In Uppadhyaya

placement of the rooms was in such a way that the rooms placed centrally didn't get exposure to sunlight. Thus, the centrally placed rooms remained dark for whole day. Even the kitchen was placed towards west so it got only evening sunlight. The house did not had proper ventilation system and no mechanism for cross ventilation. The rooms placed outside only had a proper wind flow, rest which were placed centrally had no contact with the wind and sunlight. So these rooms were dark and suffocated.

analysis

Bramahavar climate. The January, with 0 July, reaches its average of 1502 month of the ,with an average 36°C. At 25.9 July is the the year.

Orientation and

house, the

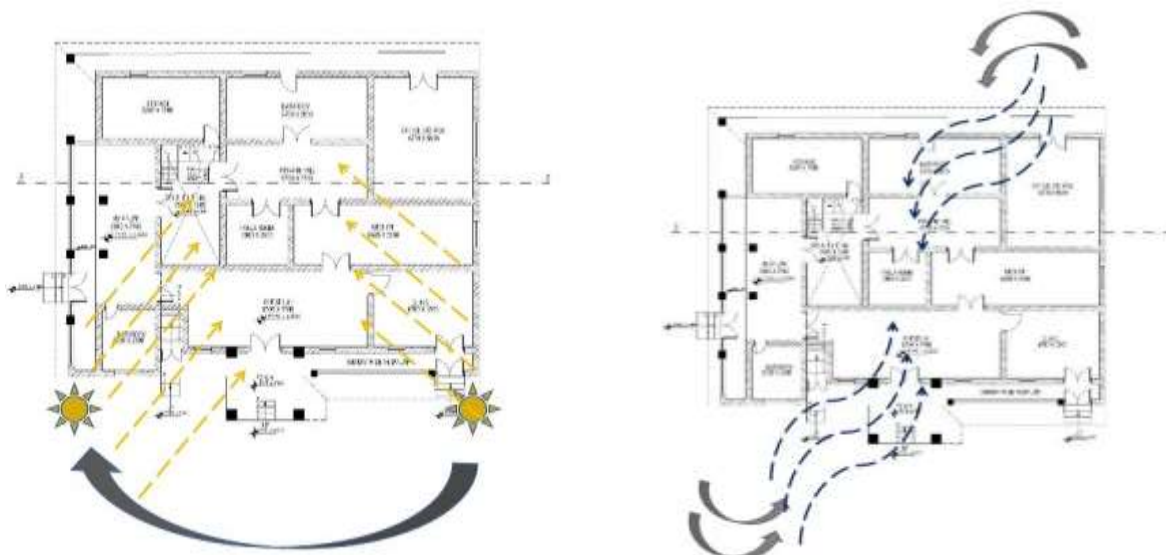

Fig.15 showing sun path and wind flow in Upadhyaya house

Source: Documentation study of Barkur and Brahmavar, by the students of IV sem B. Arch, 2017-2022 batch.

9.1.3.2 Planning technique

The planning was in square form with extended portico . So the sun light was reduced as it entered the house. The building has 3 entrances in the north, east and south and has deep veranda in east , portico in north and the south entry had storied room , so the light and warm air was reduced before entering the main rooms , and this central rooms did not got the ventilation.

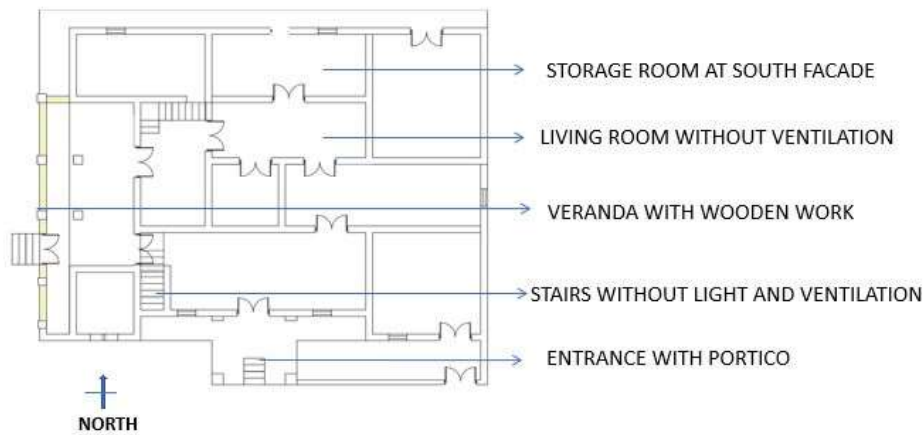

Fig.16 showing the planning technique used in Upadhyaya house.

Source: Documentation study of Barkur and Brahmavar, by the students of IV sem B. Arch, 2017-2022 batch.

9.1.3.3 WWR – Window area/ Wall area

Table.2 assessment of window to wall ratio

WALL	AREA OF WALL	AREA OF WINDOW	WWR	SHGC
North	19.5 X 3 = 58.5	(1.2X1.3)6+(1.2X1.5) = 11.16	19.07%	0.40
South	19.5 X 3 = 58.5	(1.2X1.3)3 = 4.68	8%	0.168
West	15 X 3 = 45	(1.2X1.3)2+(1.2X1.5) = 4.92	10.93%	0.23
East	17 X 3 = 51	(1.2X1.3)4 = 7.2	14.11%	0.297

9.1.3.4

Thermal

Table.3 assessment of U-value of the material

MATERIALS	THICKNESS (L) [M]	THERMAL CONDUCTIVITY [W/M.K]	THERMAL RESISTANCE (R) [M².K/W]
Brick	0.28	0.6	0.46
Lime	0.01	0.7	0.014
Cement	0.01	0.9	0.011

transmittance

$\sum 0.485$   
 $U\text{- value} = 1/\sum R = 1/0.4485 = 2.061$

The place Bramhavar is very warm and humid. As per ECBC u-value should be 0.44. Thus, Warm and humid zones mostly covers the coastal part of our country India. Therefore the relative Humidity is very high, about 70-90% throughout the year and precipitation is also high 1200mm, per year or even more.

Source: Documentation study of Barkur and Brahmavar, by the students of IV sem B. Arch, 2017-2022 batch.

**9.2 Pai house**

Pai house is a residence in Barkur, Udupi which is around 130 years old and was passed on to him through is maternal ancestors through a custom usually followed by the Tuluvas called “aliya santhana.” It is located to its north it is connected to the ratha bidi of Barkur. To its south there is an empty land with seasonal fruit trees. To its west there is a small walkway (1.2m wide) separating the neighboring house. It is a two storied structure which is square in plan with central courtyard. The area covered around the site is 2060sqm.it is a residence and a commercial space.



Fig.17 Street view at entrance of the Pai house



Fig.18 View of the Pai house

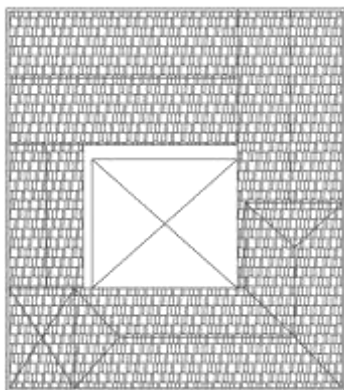

Fig.19 Site plan



Fig.20 Ground floor plan

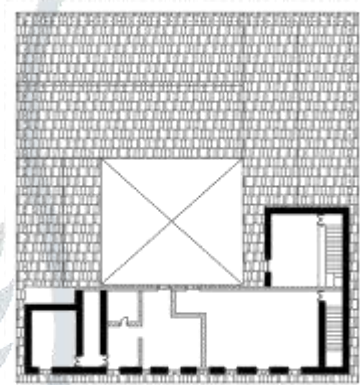

Fig.21 First floor plan



Fig.22 Section

Source: Documentation study of Barkur and Brahmavar, by the students of IV sem B. Arch, 2017-2022 batch.

**9.2.1 Construction details**

**9.2.1.1 Columns**

In this residential building, timber columns are used. it is square in plan and it has an octagonal capital.it is used in interior of the building, as timber is locally available material.

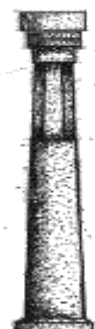

Fig.23 Timber column at

### 9.2.1.2 Doors

Timber door is used in this residence typology with an entrance door size of 1.5m. It is more ornamented with floral motive and patterns. It gives an aesthetic appeal to house.



Fig.24 Timber door at Pai house

### 9.2.1.3 External wall section

In this wall section, the materials used are locally available materials which are climate friendly. The materials used are Mangalore tiles, mud, brick and lime plaster.

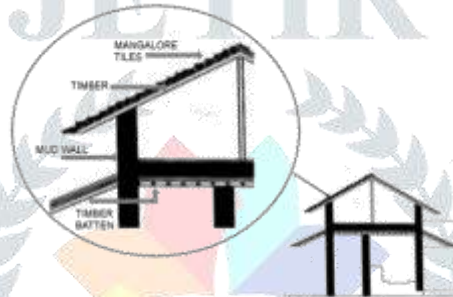

Fig.25 external wall section at Pai house

### 9.2.2 Material used

Table.4 showing the material usage in Pai house

MATERIAL	DESCRIPTION
Mangalore tiles	Mangalore tiles are good insulating material, since they are made of clay. It allows air circulation and keeps inside temperature warmer in winter and cooler in summer.
Brick	Bricks are readily available and cost efficient. they have very less insulating property but they are in use in humid areas.
Mud	mud being a versatile building material is extremely malleable and offers better insulation than steel and concrete structures
Lime plaster	These help in absorbing water vapours when humidity is high and release it when humidity becomes low, so lime plasters will regulate the internal humidity.
Timber	Timber being hygroscopic in nature has the ability to exchange moisture with the surrounding air which provides a buffer against short term changes in humidity and temperature.

### 9.2.3 Climate analysis

Barkur falls under tropical climate, which driest month is in January and coolest month is in August, and 0mm rain fall and reaches its peak with an average of 1502mm. The warmest month is in April, with an average temperature of 36-degree Celsius.

#### 9.2.3.1 Orientation and wind direction

The Pai house, placement of chawadi, living area, bedroom, study rooms are all connected to the courtyard, and main spaces of the house are kept away from south. Spaces fulfilling the main functions of the house and spaces where people stay for longer duration on average were oriented towards the north. the building was oriented in north-south direction as it helped in cutting down the harsh light and heat from south by placing important spaces away from it. It gets light only through courtyard because it has rooms around courtyard, so it gets natural light of 70% during day. Roof height is 3m so that ventilation is proper.

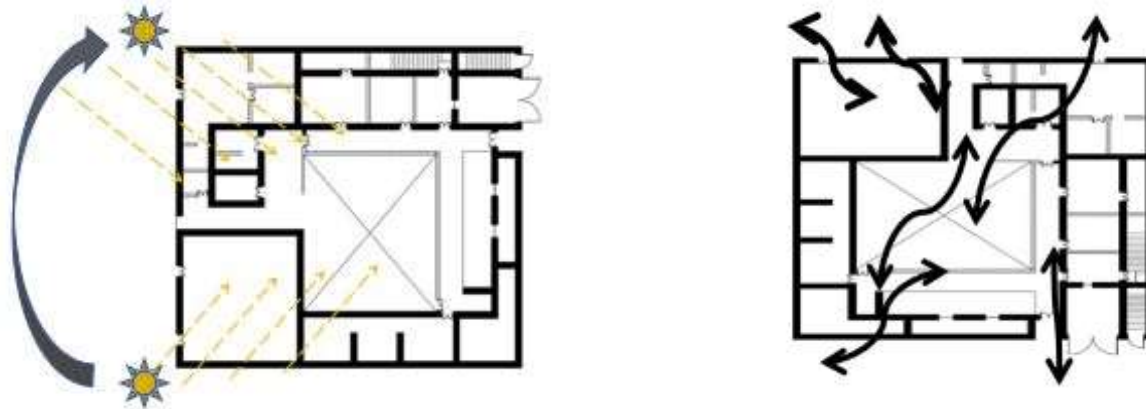

Fig.26 showing sun path and wind flow in Pai house

Source: Documentation study of Barkur and Brahmavar, by the students of IV sem B. Arch, 2017-2022 batch.

9.2.3.2 Planning technique

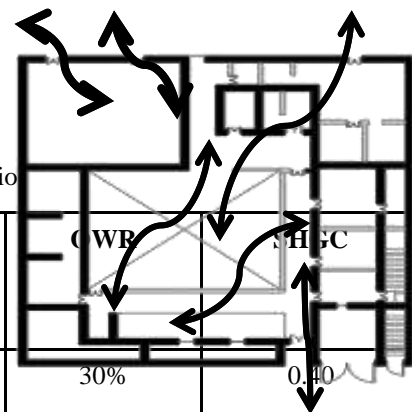

Fig.27 showing the planning technique used in Pai house.

9.2.3.3 WWR- Window area/Wall area

Table.5 assessment of window to wall ratio

WALL	AREA OF WALL	AREA OF OPENING	CWR	WEC
North	22.5x3=67.5	1.8x1.2=2.8	30%	0.40
South	22.5x3=67.5	3.6x1.2=4.3	6.3%	0.40



East	24.2x3=72.6	0	0	0
West	24.2x3=72.6	1.8x1.2=2.1	3%	0.40

### 9.2.3.4 Thermal transmittance

Barkur is in the hot and humid zone and therefore the materials used here are perfectly suitable. As the relative humidity is very high, it can be reduced by using suitable building materials.

Table.6 assessment of U-value of the material

MATERIALS	THICKNESS (L) [M]	THERMAL CONDUCTIVITY [W/M. K]	THERMAL RESISTANCE (R) [M <sup>2</sup> .K/W]
Brick	0.23	0.6	0.38
Lime	0.01	0.7	0.014
Cement	0.01	0.9	0.011
Mud	0.21	0.523	0.4015
Mangalore tiles	0.20	0.84	0.23
Timber	0.15	0.97	0.15

Source: Documentation study of Barkur and Brahmavar, by the students of IV sem B. Arch, 2017-2022 batch.

## X. INFERENCE

### 10.1 Climate

Courtyard is the vital space in vernacular dwellings. It is the focal point of the dwelling and acts as an activity generator. It is the source of lighting and ventilation and makes the house climatically responsive. It plays a major role in the behavioural aspects of inmates by bringing nature to the interior.

The spaces are minimum and accommodate multiple activities at various time periods. No space is left unused for more than one hour in a day. Flowing of flexible spaces encourages family interaction at a higher degree.

The buffer spaces such as Thinnai and Thazhvaram (passage around the court) allow a gradual and smooth transition of movement from exterior to interior. In addition, it encourages and facilitates interaction with people leads to strengthening of societal bonding. The desirable thermal comfort conditions are achieved in these houses with no or minimum use of mechanical devices.

### 10.2 Materials and construction details

It is clear from the analysis that, the bond between the materials and the nature and the way they react or respond to the nature will never change. It is only the link between the people and the materials and the way they look at the materials and using them is getting changed in time which has impact on its architecture. It is very much essential to respect and learn valuable lessons from the past as the present scenario forces people to get away from the box in box life style due to globalization, modernization and urbanization at least for a short duration.

It is all achieved mainly due to its planning aspects in terms of its plan, elevation, section, form and other architectural details of the Construction. The materials used and the techniques adopted may be expensive and time consuming in present condition but the context and relevance of these aspects in satisfying the users need is highly appreciable and the essence of these need to be explored in modern context.

## XI. LIMITATIONS

Barkur and Brahmavar had various residence typologies which it had to studied in certain period of time. Due to time constraint, minimal residence typology analysis has been done inconsideration with different Parameters.

## XII. Propose of Design strategies to achieve sustainability in modern residential buildings

### 12.1 Courtyard placement

Courtyards have been generally referred to as a microclimate changer, due to their ability to mitigate high temperatures, channel breezes and adjust the degree of humidity (Saxon, 1986). Courtyards also were acting as a source of airflow thermal comfort to the

residence. With right position to the house and suitable material, it can also help to reduce the heat gain and this will act efficiently with the properties of self-shading and thermal lag. Finally, courtyard acts like a cool air reservoir.

courtyards shows that the use of soil and grass instead of concrete pavements, in addition to the application of greeneries and waterbodies, lead to cooling effects in summer .Simulations in summer confirm that water pools lead to a decrease in air temperature by 0.2 C and the use of soil and grass results in 0.2-0.6 C air temperature reductions .

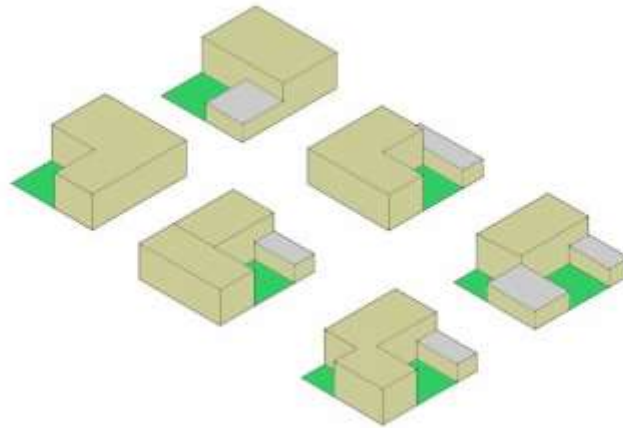
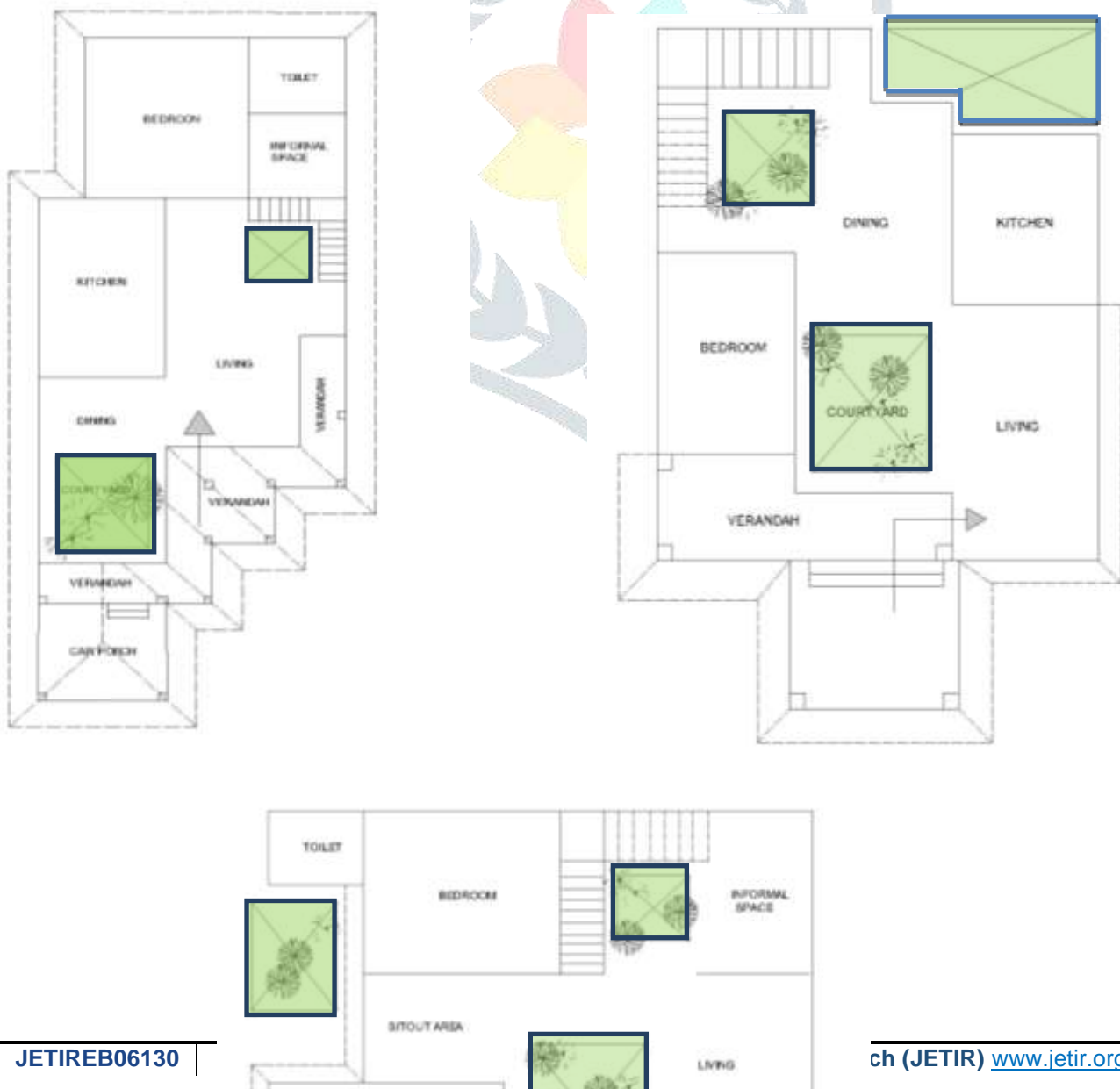

Fig.28 Combination of Courtyard placements

Source: Author,2020

12.1.1 Courtyard placement in a Modern residential building



Source: Author

Fig.29 Courtyard placements in a modern residential building.

Source: Author,2020

**12.2 Buffer zones**

Buffering zones acts as insulating areas from preventing heat getting into living spaces. Thinai, Verandas and Attic are some examples of Buffering zones. The Attic acts as a Buffering zone by preventing heat entering the living space with help of insulating layer between attic and living area. Hereby to increase the efficiency, Greeneries, Waterbodies can be adapted.

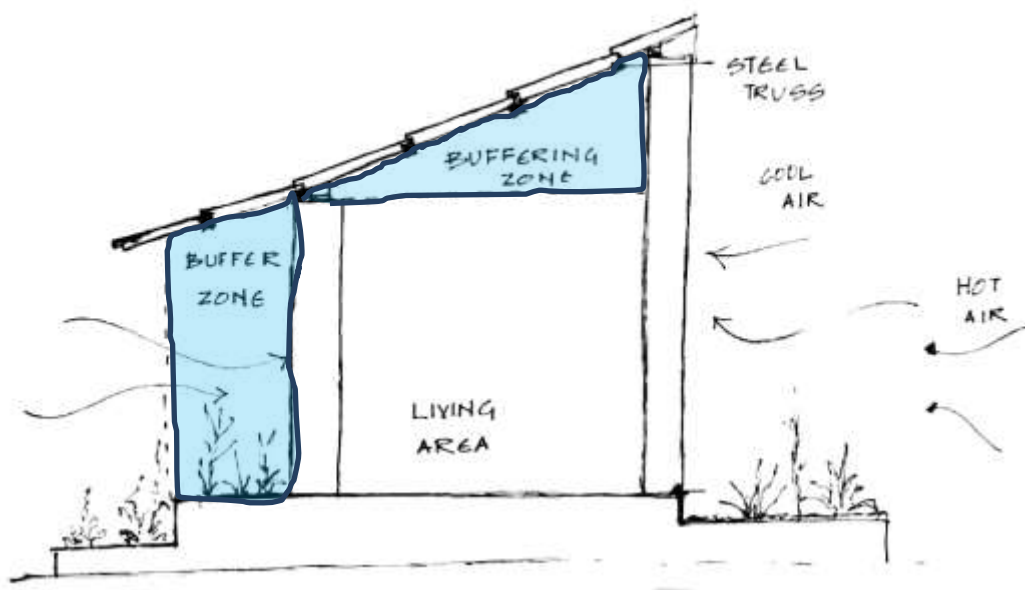

Fig.30 Section showing at Buffering zones

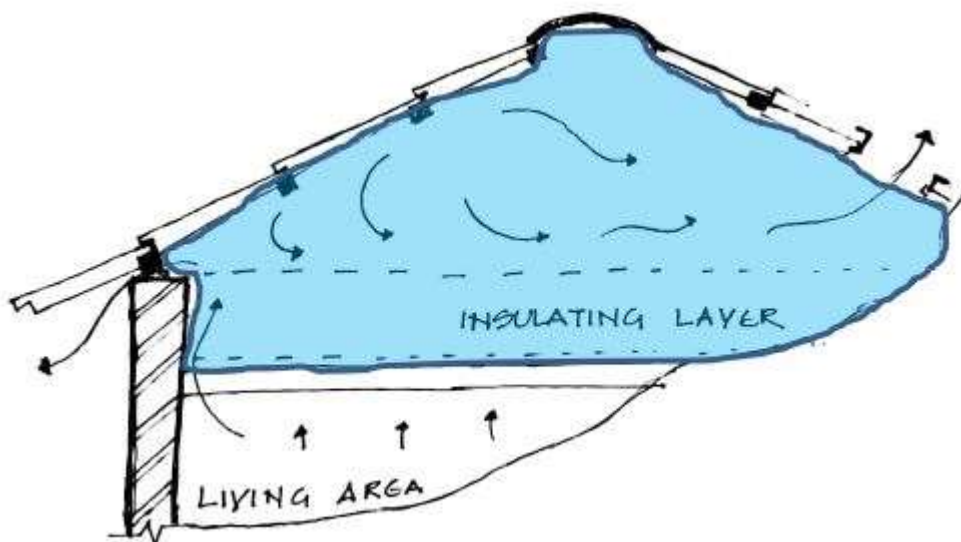



Fig.31 Buffering zone at Attic space

Source: Author,2020

### 12.2.1 Buffer zones placement in a Modern residential building



Fig.32 Buffering zones in a modern residential building.

Source: Author,2020

**12.3 Roofing system and Material usage**

It is a proposal where we can see more of wooden trusses were used in Barkur and Bhravar. So strategically we can use steel as a modern material in constructing a truss with the amalgamation with old vernacular material. Using a single purling, you can fix both roof tile as well as ceiling tiles, which will give you aesthetically appealing functional roof. You can also differently underlie sheets (See Roofing Components for Details) in between the roof tiles and ceiling tiles to make the roof 100% waterproof. You can choose either Rain Shield, Radiant Barrier or Volition sheet to check the leakage forever. Used on steel or iron fabrication for under Mangalore tiles or any other roof tiles for aesthetic appeal and thermal insulation.

This steel structure covered with clay tiles gives you a cool eco-friendly structure for you. Let it be small extension over your penthouse or a car parking area or let it be a huge structure like your halls or a factory unit the steel fabricated terracotta structure is ideal.

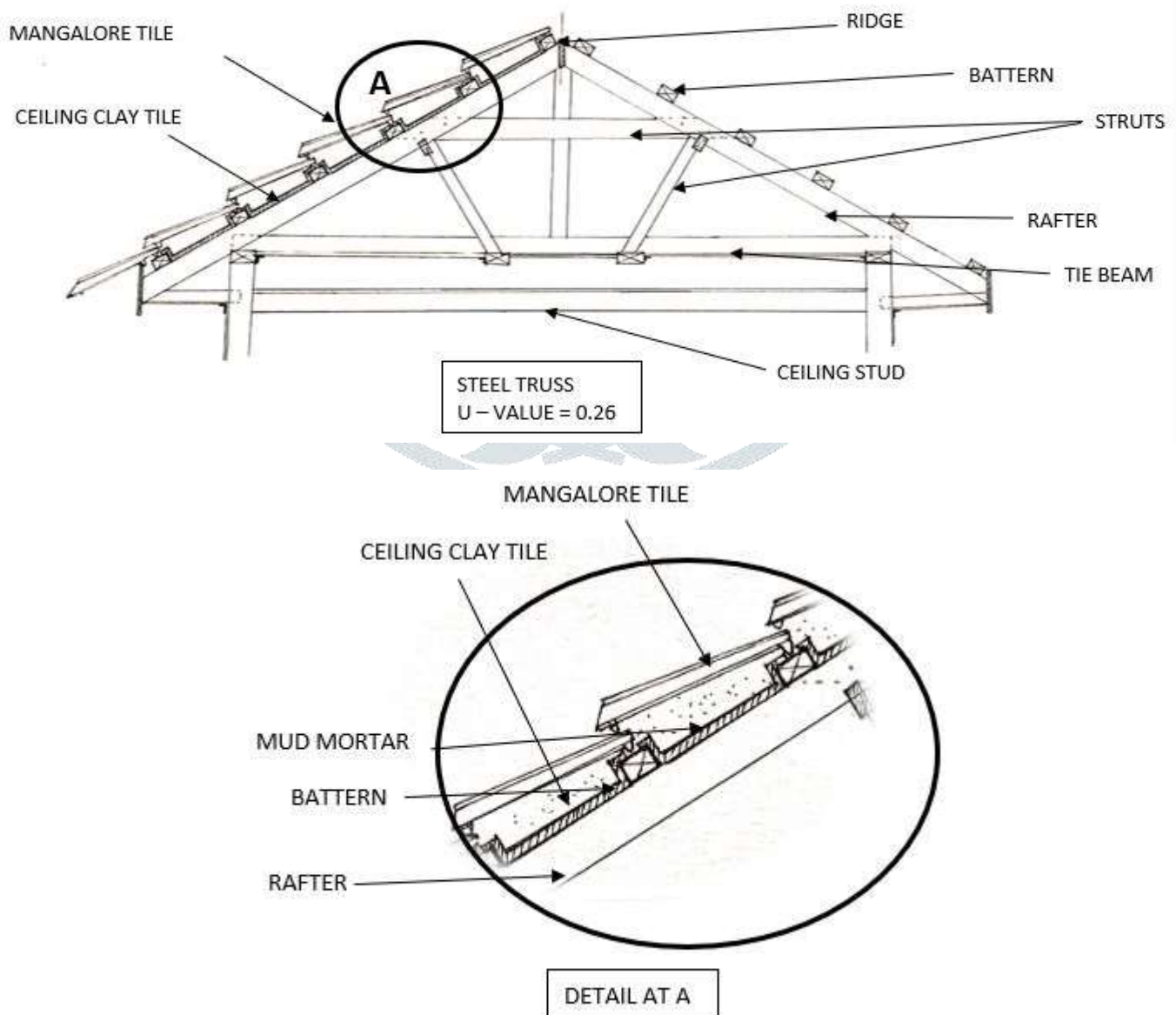
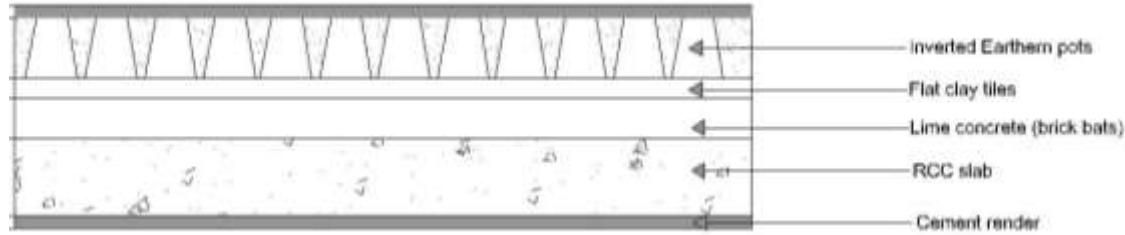

Fig.33 Roofing system for a modern residential building.

Source: Author,2020

12.3.1 Attic, Flooring and Walls



Materials used	Thickness in m	U-value
Inverted Earthen pots	0.2	<b>2.04</b>
Flat clay tiles	0.02	
Lime concrete (brick bats)	0.05	
RCC slab	0.1	
Cement mortar	0.01	

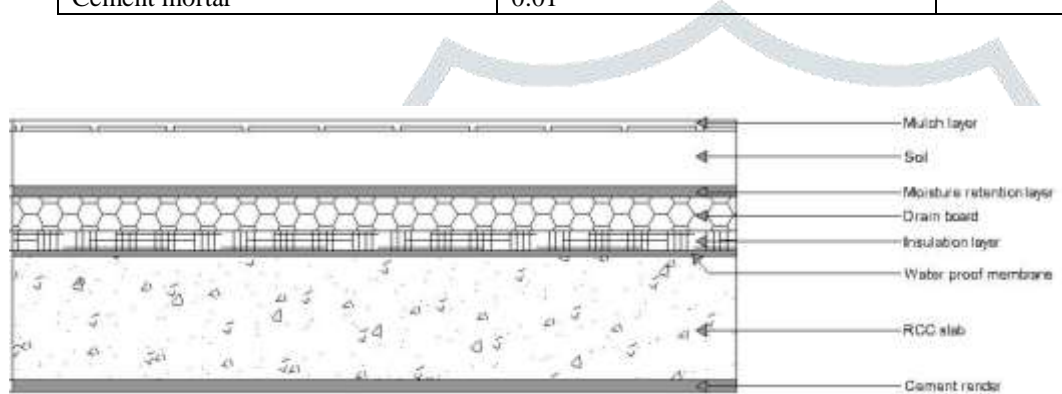

Materials used	Thickness in m	U-value
Mulch layer	0.02	<b>0.4</b>
soil	0.1	
Moisture retention layer	0.025	
Drain board	0.05	
Insulation layer	0.025	
RCC slab	0.2	
Cement mortar	0.01	



Materials used	Thickness in m	U-value
Flat clay tiles	0.02	<b>3.09</b>
Lime concrete (brick bats)	0.05	
RCC slab	0.1	
Cement mortar	0.01	

Source: IS: 3792 – 1978, Guide for heat insulation of non-industrial buildings, pg. no 20-22.

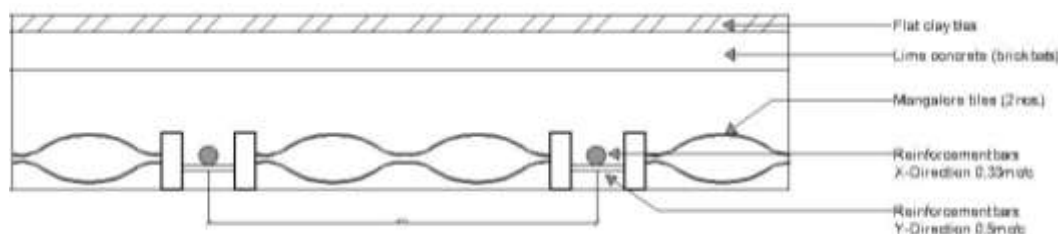

Materials used	Thickness in m	U-value
Flat clay tiles	0.02	3.35
Lime concrete (brick bats)	0.05	
Mangalore tiles	2 nos.	
Reinforcement bars	x-direction= 0.33m c/c y- direction= 0.5m c/c	

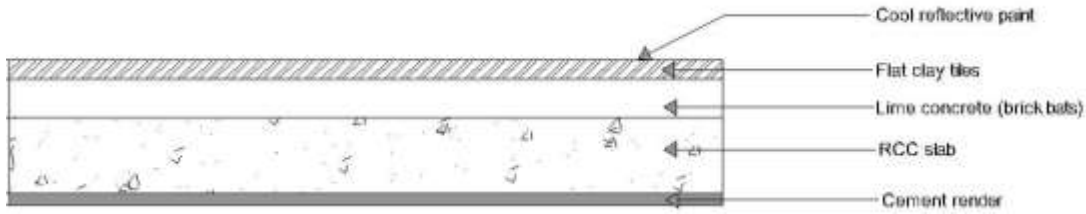

Materials used	Thickness in m	U-value
Cool reflective paint	negligible	2.44
Flat clay tiles	0.02	
Lime concrete (brick bats)	0.05	
RCC slab	0.1	
Cement mortar	0.01	

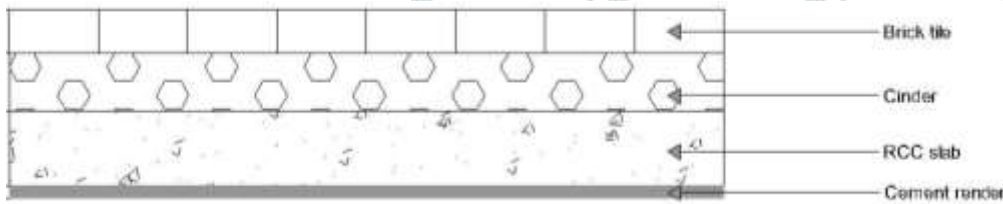

Materials used	Thickness in m	U-value
Brick tile	0.05	1.76
Cinder	0.075	
RCC slab	0.1	
Cement mortar	0.01	

Source: IS: 3792 – 1978, Guide for heat insulation of non-industrial buildings, pg. no 20-22.

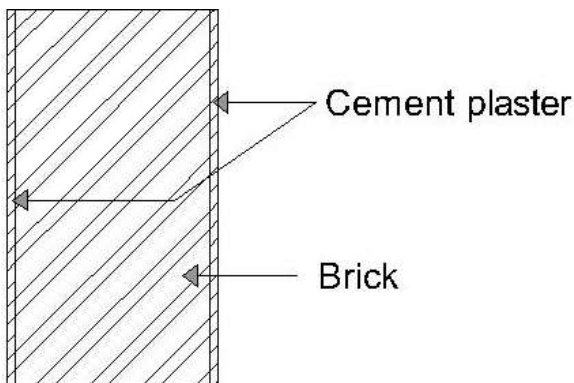

Materials used	Thickness in m	U-value
Cement plaster	0.012	1.35
Brick	0.45	

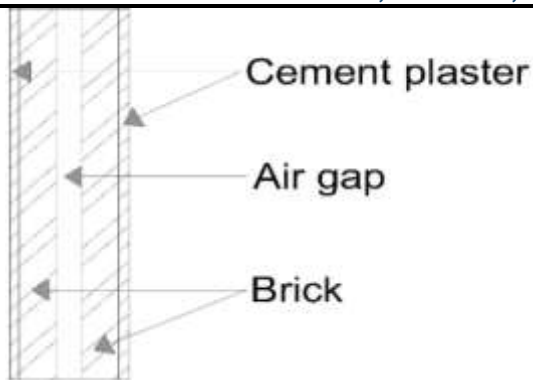

Materials used	Thickness in m	U-value
Cement plaster	0.012	1.8
Brick	0.075	
Air gap	0.5	

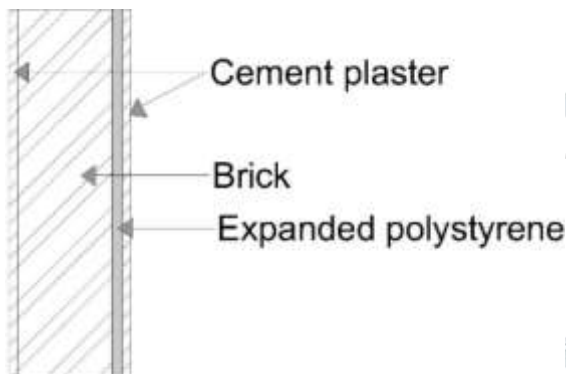

Materials used	Thickness in m	U-value
Cement plaster	0.012	0.85
Brick	0.225	
Expanded polystyrene	0.025	

Source: IS: 3792 – 1978, Guide for heat insulation of non-industrial buildings, pg. no 20-22.

### XIII. CONCLUSION

Above design strategies to be incorporated in modern residential building in Barkur and Bhramavar leads to higher efficiency, positive tolerance and offers higher performance towards modern residential buildings, were the locally available materials usage are completely diminished in a modern residential building leading or going against Climatic conditions, materials usage and Construction technology adopted earlier in Barkur and Bhramavar. Thus, the design strategies will give high performance output against Climatic conditions, Materials usage and Construction technology towards the Modern residential building by enhancing the above strategies for a better livelihood.

### XIV. REFERENCES

- [1] Indah Widiastuti, School of Architecture, Planning and Policy development- SAPPD, Institute of Technology, Bandung (ITB), Indonesia, Journal of the International Society for the Study of Vernacular Settlements 41, The Living Culture and Typo-Morphology of Vernacular Houses in Kerala, ISVS e-journal, Vol. 2, no.4, September, 2013.
- [2] Indian Journal of Traditional Knowledge, A study on sustainable design principles: A case study of a vernacular dwelling in Thanjavur region of Tamil Nadu, India. Vol. 13 (4), October 2014, pp. 762-770.
- [3] Rajeev Parashar and Sudheer Singh Sikarwar, Design Strategies for Contemporary Coastal Architecture, December 2017, IJIRT, Volume 4 Issue 7, ISSN: 2349-6002
- [4] 1stsearc symposium, nus, 8-9 January 2015, Indah widiastuti, the vernacular architecture of Kerala, south India: an architecture knowledge on the cross-road between southeast Asia and south Asia.
- [5] DOI: 10. 21276.iajmr.2016.2.4.1, Asian Journal of Multidisciplinary Research (IAJMR), ISSN: 2454-1370, vol. 2, issue – 4 ,2016.
- [6] Foruzanmehr, Ahmadrza, and Marcel Vellinga. "Vernacular architecture: questions of comfort and practicability." Building Research & Information 39.3 (2011): 274-285.
- [7] Documentation study of Barkur and Brahmavar, by the students of IV sem B. Arch, 2017-2022 batch.
- [8] IS: 3792 – 1978, Guide for heat insulation of non-industrial buildings, pg no 20-22.
- [9] Madhu mathi, Subhashini Selvaraj, Vishnu Priya, Department of Architecture, Thiagarajar College of Engineering, Madurai, Tamil nadu, the urban heat island effects its causes and mitigation with reference to the thermal properties of roof coverings, on 15 July 2018.

- [10] Fig 1. Types of Ekalasa with Alindam function as Veranda, Source: Indah widiastuti,2004 ISVS e-journal, Vol. 2, no.4, September, 2013.
- [11] Fig 2. Bhonga hut, Source: design strategies for contemporary coastal architecture, December 2017, IJIRT, Volume 4 Issue 7
- [12] Fig 3. Kerala vernacular housing, Source: design strategies for contemporary coastal architecture, December 2017, IJIRT, Volume 4 Issue 7
- [13] Fig 4. Comparison of Saddle-Hipped Roof of House in Kottayam District, Kerala, India and Batak Karo, Source: Foruzanmehr, Ahmadrza, and Marcel Vellinga.
- [14] Fig.5 Street view at entrance of the Upadhyaya house, Source: Documentation study of Barkur and Brahmavar, by the students of IV sem B. Arch, 2017-2022 batch.
- [15] Fig.6 View of the Upadhyaya house Source: Documentation study of Barkur and Brahmavar, by the students of IV sem B. Arch, 2017-2022 batch.
- [16] Fig.7 Site plan, Source: Documentation study of Barkur and Brahmavar, by the students of IV sem B. Arch, 2017-2022 batch.
- [17] Fig.8 Ground floor plan, Source: Documentation study of Barkur and Brahmavar, by the students of IV sem B. Arch, 2017-2022 batch.
- [18] Fig.9 First floor plan, Source: Documentation study of Barkur and Brahmavar, by the students of IV sem B. Arch, 2017-2022 batch.
- [19] Fig.10 Section, Source: Documentation study of Barkur and Brahmavar, by the students of IV sem B. Arch, 2017-2022 batch.
- [20] Fig.11 Plans of column, Source: Documentation study of Barkur and Brahmavar, by the students of IV sem B. Arch, 2017-2022 batch.
- [21] Fig.12 Timber column at Upadhyaya house, Source: Documentation study of Barkur and Brahmavar, by the students of IV sem B. Arch, 2017-2022 batch.
- [22] Fig.13 Timber door at Upadhyaya house, Source: Documentation study of Barkur and Brahmavar, by the students of IV sem B. Arch, 2017-2022 batch.
- [23] Fig.14 External wall section of Upadhyaya house, Source: Documentation study of Barkur and Brahmavar, by the students of IV sem B. Arch, 2017-2022 batch.
- [24] Table.1 showing the material usage in Upadhyaya house, Source: Documentation study of Barkur and Brahmavar, by the students of IV sem B. Arch, 2017-2022 batch.
- [25] Fig.15 showing sun path and wind flow in Upadhyaya house, Source: Documentation study of Barkur and Brahmavar, by the students of IV sem B. Arch, 2017-2022 batch.
- [26] Fig.16 showing the planning technique used in Upadhyaya house, Source: Documentation study of Barkur and Brahmavar, by the students of IV sem B. Arch, 2017-2022 batch.
- [27] Table.2 assessment of window to wall ratio, Source: Documentation study of Barkur and Brahmavar, by the students of IV sem B. Arch, 2017-2022 batch.
- [28] Table.3 assessment of U-value of the material, Source: Documentation study of Barkur and Brahmavar, by the students of IV sem B. Arch, 2017-2022 batch.
- [29] Fig.17 Street view at entrance of the Pai house, Source: Documentation study of Barkur and Brahmavar, by the students of IV sem B. Arch, 2017-2022 batch.
- [30] Fig.18 View of the Pai house, Source: Documentation study of Barkur and Brahmavar, by the students of IV sem B. Arch, 2017-2022 batch.
- [31] Fig.19 Site plan, Source: Documentation study of Barkur and Brahmavar, by the students of IV sem B. Arch, 2017-2022 batch.
- [32] Fig.20 Ground floor plan, Source: Documentation study of Barkur and Brahmavar, by the students of IV sem B. Arch, 2017-2022 batch.
- [33] Fig.21 First floor plan, Source: Documentation study of Barkur and Brahmavar, by the students of IV sem B. Arch, 2017-2022 batch.
- [34] Fig.22 Section, Source: Documentation study of Barkur and Brahmavar, by the students of IV sem B. Arch, 2017-2022 batch.
- [35] Fig.23 Timber column at Pai house, Source: Documentation study of Barkur and Brahmavar, by the students of IV sem B. Arch, 2017-2022 batch.
- [36] Fig.24 Timber door at Pai house, Source: Documentation study of Barkur and Brahmavar, by the students of IV sem B. Arch, 2017-2022 batch.
- [37] Fig.25 external wall section at Pai house, Source: Documentation study of Barkur and Brahmavar, by the students of IV sem B. Arch, 2017-2022 batch.
- [38] Table.4 showing the material usage in Pai house, Source: Documentation study of Barkur and Brahmavar, by the students of IV sem B. Arch, 2017-2022 batch.
- [39] Fig.26 showing sun path and wind flow in Pai house, Source: Documentation study of Barkur and Brahmavar, by the students of IV sem B. Arch, 2017-2022 batch.
- [40] Fig.27 showing the planning technique used in Pai house, Source: Documentation study of Barkur and Brahmavar, by the students of IV sem B. Arch, 2017-2022 batch.
- [41] Table.5 assessment of window to wall ratio, Source: Documentation study of Barkur and Brahmavar, by the students of IV sem B. Arch, 2017-2022 batch.
- [42] Table.6 assessment of U-value of the material, Source: Documentation study of Barkur and Brahmavar, by the students of IV sem B. Arch, 2017-2022 batch.
- [43] Fig.28 Combination of Courtyard placements, Source: Author, 2020.
- [44] Fig.29 Courtyard placements in a modern residential building, Source: Author, 2020.
- [45] Fig.30 Section showing at Buffering zones, Source: Author, 2020.

- [46] Fig.31 buffering zone at Attic space, Source: Author, 2020.
- [47] Fig.32 Buffering zones in a modern residential building, Source: Author, 2020.
- [48] Fig.33 Roofing system for a modern residential building, Source: Author, 2020.

