



Design and Automation of Bar Shear Press Machine

Raj Pokale¹, Shreyas Patil², Prasad Gaikwad³ Abhishek Jadhav⁴ Prof. S. C. Shinde⁵Department of Mechanical Engineering, SKNCOE, SPPU, Pune

Abstract— In the modern world through there are many developments in the field of engineering still there are difficulties to simple work process without human efforts. In the industry a worker is always needed to push the work log in bar shear press machine at to actuate the cutting mechanism Therefore due to semi automation of the machine the human efforts as well as the machine potential ability was getting wasted. Even though the human efforts were involved the work rate was quite less and hence it further delayed the automated processes which involved automatic casting machine, CNC, feeding machine. At times the worker might make a mistake of holding the rod in a wrong position and end up cutting it in a non-parallel position hence letting the entire rod go waste also pushing the rod is a very dangerous process with the risk of accidental harm. Project we have been working aims at simplifying the work and atomizing it simultaneously increasing the work rate and accuracy.

The main objective of the project is to achieve higher the productivity as well as accuracy of cutting and reduce the human efforts. The process getting smooth.

This project includes designing the Bar feeding machine using CAD software like CATIA and simulation using ANSYS and PROTEUS. It also endeavors to study the commercial viability and importance of such a product. Firstly, we thought about different ideas on solving the task of feeding the rod without any human efforts. Out of these a few ideas we came up with were a bit costly and complicated to be implemented. Through applying all permutations and combinations we came up with simple idea/model which ended up being cost effective with a high potential of increased production rate, robust and simple to be executed which we will be further describing in these project.

Keywords— CNC, Bar, Shear, Feeder, Automation, Design

I. INTRODUCTION

A bar feeder seems like a relatively simple device. The most common automation accessory in our world of high volume turning, it provides a reliable way of delivering material to the machine tool for extended periods of time, saving an operator from continually loading blanks into a chuck. A bar feeder consists of some sort of *bed* that supports bundles of bar stock (it could be circular), a *bar pusher* that moves the stock through the end of the feeder and into the chuck, a *clamping mechanism*, and a system to adjust the position of the feed. The **bar** is generally not flat, but curved or angled so that all the bars are always resting at the bottom of the bed and are ready to be inserted into the machine. Often these will have rollers or other ways of ensuring smooth bar movement down to the bottom. The **bar pusher** can be controlled in a few different ways--either using pressurized oil or air, or using a servomotor with a push rod. Several **clamps** and anti-vibrational devices hold the rod in place as it turns, ensuring accuracy and stability. The bar feeder will also have various ways to adjust the position of the bar so that it lines up in the center of the hole for the chuck.

II. METHODOLOGY

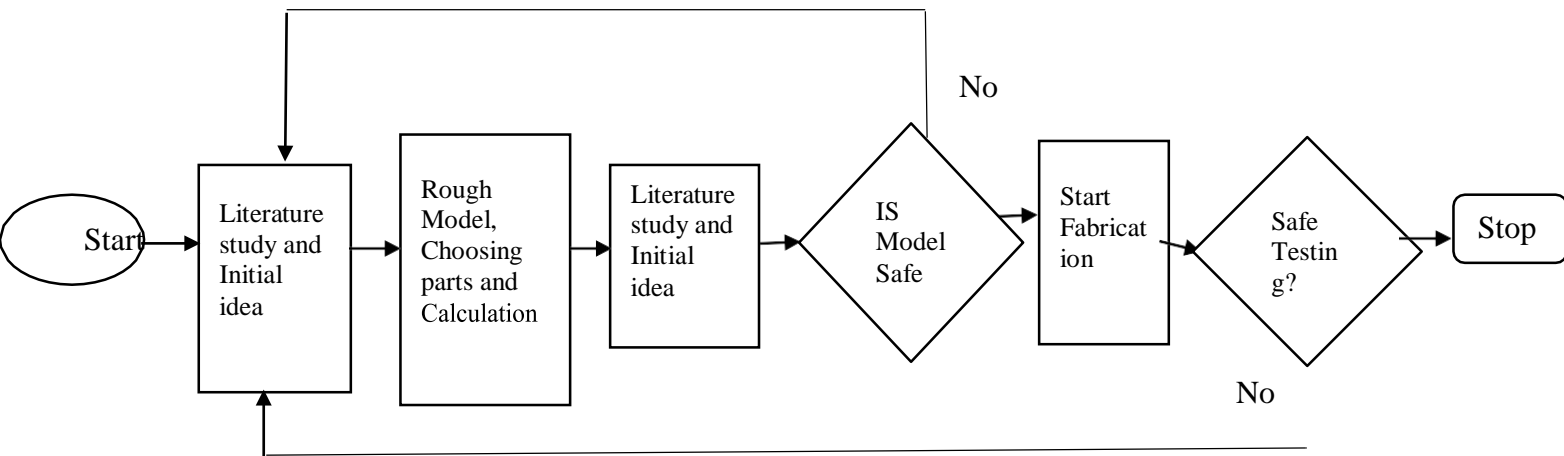

III. DESIGN

A. Initial Representation of the Idea

After reviewing the different literatures reviews and thesis, the pulley mechanism, rotated by belt drive is finalized for feeding the rod to the cutting machine. The 6 pulleys, 4 for lower and 2 for upper side. From the 4 below, one pulley is with the double grooves and other all are single groove. Double groove for the belt drive. Motor is controlled by Arduino and on motor shaft pulley is fixed. This pulley is connected to rod feeding pulley by belt. As motor pulley start rotating, the feeding pulley also start rotating. The below figure shows the basic idea of the bar feeding machine.

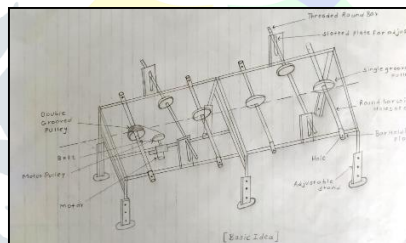

B. Complete CAD assembly of bar feed to shear press machine

Complete assembly contains pulley, square channel, support base of square channel, belt drive, rod, square channel different size, motor, motor pulley, and more is assembled in CATIA. The lower pulley is assembled in one line in first pulley the second pulley is fix. The motor is assembled in such manner that the belt is fit in pulleys. In bottom the two square channel is fix for height adjustment. The bolt is fix in the two square channel. Make the square channel frame to fix the motor. The two upper pulley is fix such manner that they are also the height adjustable. On the lower pulley fix the bar which to be cut and upper pulley adjust to touch the bar. In the bottom of square channel fix the square plate to not insert in ground or damage the ground. This is full assembly of the bar feed to shear press machine.

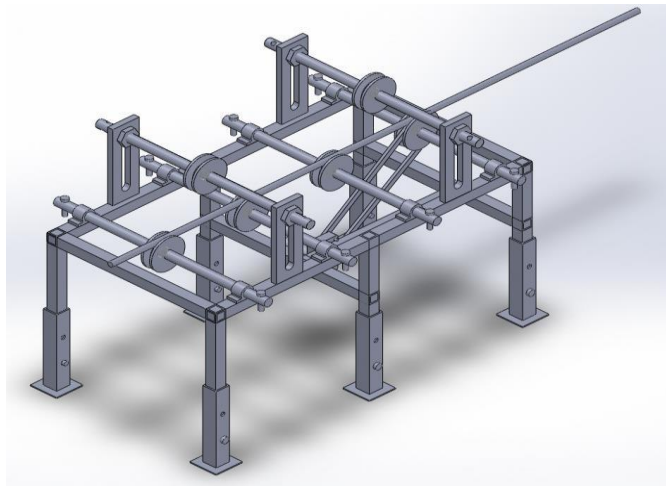

C. Static Structural Analysis Using ANSYS 2021

The weight of the bar is 50 to 90 kg and the total pressure is on the pulley but the four pulleys distribute the pressure. While applying the constraints, load conditions and boundary conditions the weight of 70 Kg has to be convert into the pressure or force that is going to applied on the specified area. On the pulley the inner diameter is a fixed support connected to rod. The rotational velocity of pulley is 2.6 rad/s. Due to the pressure on the pulley, some deformation of pulley is happen so, have to calculate the total deformation, equivalent stress, and equivalent elastic strain. By calculating this terms the benefit is to select the material and product. In given figure the total deformation, stress and strain is given below.

Total Deformation of Pulley

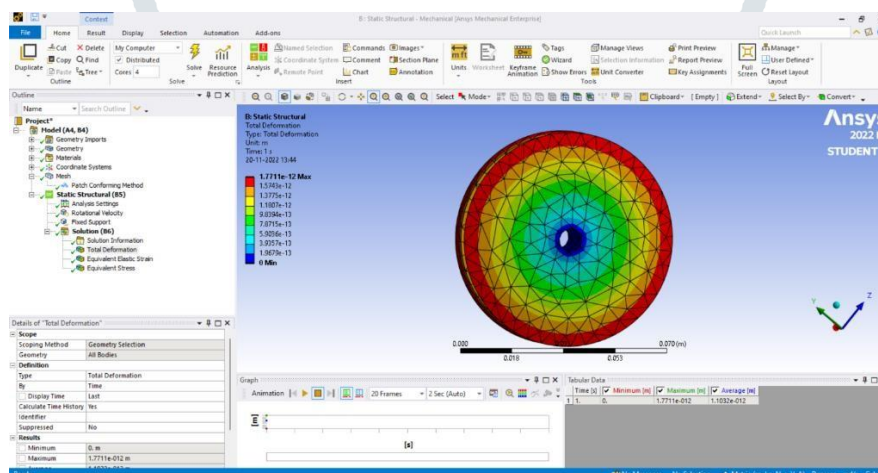

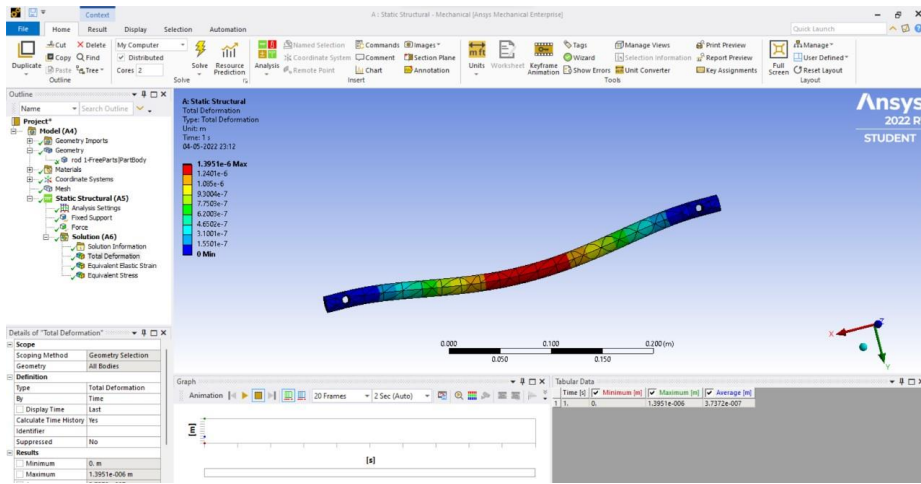

Total Deformation of Rod

IV. FABRICATION

As per the design created using the CAD software CATIA, the prototype is manufactured using the structural steel square shape pipes. All the mechanisms are integrated into the prototype as per the design and calculations made for the machine elements. Some minor modifications are done for cost saving and material saving as per the suggestions from fabricator. There are six different types of fabrication processes that take place into the making of prototype and are assembled together to form the model namely:

- 1) Cutting.
- 2) Drill Process
- 3) Grooving Plates
- 4) Threading
- 5) Welding
- 6) Arc Welding



Welding of Square Channel (Base)



Pulley Assembly

V. CONCLUSIONS

- ❖ Due to this automation the fed rod is freely moved into the cutting machine which smoothens the whole process.
- ❖ This process increases accuracy due to stabilization of the rod, it also reduces work efforts.
- ❖ This design is proven safe by considering the safety factors after calculating shear stress and bending stress of external feeder.
- ❖ All the parameters are found using models from Ansys and Catia Eg:- stress, deformation, strain.
- ❖ Selection of pulley is done by pulley analysis and the length of the belt drive is derived from empirical relation.
- ❖ We tried to maintain the structure of the feeder as flexible as possible for different kinds of dimensions of rod and various other aspects.
- ❖ The total cost of the setup is being calculated prior the manufacture so as to keep the setup as cost efficient as possible.
- ❖ It's an external system which attaches to the main machine as an accessory and hence there wasn't any need to make any changes in the primary mechanism. This led the feeder to be efficient as well as adaptive.
- ❖ Manufactured prototype is tested physically at Department of Mechanical Engineering, Vishwakarma Institute of Information Technology, Pune.

ACKNOWLEDGMENT

I take this opportunity to thank all those who have contributed in successful completion of this Project Stage -1 work. I would like to express my sincere thanks to my guide **Prof. S. C. SHINDE**, who have encouraged me to work on this topic and provided valuable guidance wherever required. I also extend my gratitude to **Prof. T. S. Sargar (H.O.D Mechanical Department)** who has provided facilities to explore the subject with more enthusiasm.

I express my immense pleasure and thankfulness to all the teachers and staff of the **Department of Mechanical Engineering of Smt. Kashibai Navale College of Engineering** for their co-operation and support.

REFERENCES

- [1] Saipratik Dhanpal Admuthe, Pratibha Tukaram Patil *Assistant Professor*. (2022). "Design And Development Of Automatic Bar Feeding Mechanism". International Journal Of Recent Advances In Multidisciplinary Topics.
- [2] Ashvin S. Patel, Dr. J. M. Prajapati. (2011). "A Review On Innovation Of Wire Straightening Cutting Machine". International Journal Of Engineering Science And Technology (IJEST).
- [3] Prof. S.D. Bhalekar, Vikas S. Vishwakarma, Arvind Umbarkar, Bhaskar M. Tale. () "Automatic Stack Feeding Machine". IOSR Journal of Mechanical and Civil Engineering (IOSR-JMCE).
- [4] Tang Wenxian, Zhu Hui, Zhu Mrngxiu, Li Qinfeng, Zhang Jian, (2016), "Research On Key Technology Of Wire-Bending And Equipment Development". Management Science And Engineering.
- [5] Bhavesh. P. Patel, A. S. Patel, P. M. Patel, R. H. Patel. (2010). "Productivity Improvement Through Automation Of Cutting Head In Wire Straightening Cutting Machine". International Conference On Science And Engineering: ICSE-2010.
- [6] T.S.S. Jayawardene, Masatoshi Nakamura, And Satoru Goto . (2003). "Accurate Control Position Of Belt Drives Under Acceleration And Velocity Constraints ". International Journal Of Control, Automation, And Systems.
- [7] Lingyuan Kong, Robert G Parker. (2005). "Steady Mechanics Of Belt-Pulley Systems". Journal Of Applied Mechanic