

Permissibility of Interconnection of Individual Two-Port Networks

Minesh K Joshi ^{1*}, Paresh R Modha ^{2*} and Chandani S Parmar ^{3*}

¹Electrical Engineering Department, A D Patel Institute of Technology, India

²Electrical Engineering Department, A D Patel Institute of Technology, India

³Electrical Engineering Department, A D Patel Institute of Technology, India

Abstract

The Two-Port Network can be connected either in series, Parallel or combination of both. The following paper discusses the condition required for series, parallel connection of the two, two –port networks. Before two individual networks are interconnected, it should be figure out that once the connection are made, the port relations of the individual two port networks are not affected. Author has discussed the case by taking series connection of two individual networks and results are figure out by simulation in MATLAB. Moreover, experimental approach also elaborates for series-series connection of two port network.

Keywords-Two-Port Networks, Series Connection, Parallel Connection.

I. INTRODUCTION

A two port network is simply a network with four terminals which are arranged into pairs called ports. In general, there will be an input port and an output port for networks.

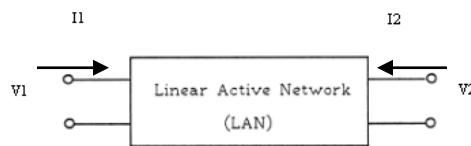

Figure 1. Two Port Network

As shown in the figure that input voltage is V_1 and current is I_1 where as Output voltage is V_2 and Current is I_2 . Out of this any two will be taken as an Input Variables and Other are Output variables with reference to respected Parameters. There is z (Open Circuit), y (Short Circuit), h (Hybrid), ABCD (Transmission) parameters.

Sr. No.	Name	Express (Independent Variables)	In Terms of (Dependent Variables)	Defining Equations
1	Impedance (z-Open Circuit)	V_1, V_2	I_1, I_2	$V_1 = z_{11}I_1 + z_{12}I_2,$ $V_2 = z_{21}I_1 + z_{22}I_2$
2	Admittance (y -Short Circuit),	I_1, I_2	V_1, V_2	$I_1 = y_{11}V_1 + y_{12}V_2,$ $I_2 = y_{21}V_1 + y_{22}V_2$
3	Hybrid (h)	V_1, I_2	I_1, V_2	$V_1 = h_{11}I_1 + h_{12}V_2,$ $I_2 = h_{21}I_1 + h_{22}V_2$
4	Transmission (ABCD)	V_1, I_1	$V_2, -I_2$	$V_1 = AV_2 - BI_2,$ $I_1 = CV_2 - DI_2$

Table1. Different Types of Parameters

II. INTER CONNECTION OF TWO PORT NETWORK

A network is defined as two or more than two elements are interconnected each other. A two port network with a modest level of complexity can be interconnected in many different ways. Either they are connected in series or in parallel or combination of series-Parallel or parallel-series and also in cascade connection.

For each set of different configuration a suitable parameter can be more useful than others to describe the network. Below table shows the overall parameter matrix for various interconnection of two port network.

Sr. No	Type of Interconnection	Individual Parameters Matrix	Overall Parameters Matrix	Comment
1	Cascade	$[T_a], [T_b]$	$[T] = [T_a][T_b]$	ABCD Parameters are multiplied
2	Series-Series	$[z_a], [z_b]$	$[z] = [z_a] + [z_b]$	z- Parameters are added
3	Parallel-Parallel	$[y_a], [y_b]$	$[y] = [y_a] + [y_b]$	y- Parameters are added
4	Series- Parallel	$[h_a], [h_b]$	$[h] = [h_a] + [h_b]$	h- Parameters are added
5	Parallel- Series	$[g_a], [g_b]$	$[g] = [g_a] + [g_b]$	g- Parameters are added.

Table 2. Different Types Interconnection of Two-Port Parameters

III. TEST FOR SERIES -CONNECTED TWO PORT NETWORK

To check permissibility of series interconnection the input ports are connected in series and output ports kept open as shown in the below figure.

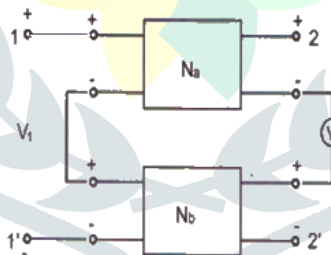

Figure 2. Test for Series Connected Two Port Network

The open circuits are used as a characterizing the individual two ports and the overall two ports are the open circuit impedance parameters. If the reading of voltmeter connected as shown in the above circuit diagram will be zero and also the voltage across the terminal which is shown shorted is zero than two individual networks can be made in series otherwise if the voltage is non zero there will be circulating current. In others, we can say that KVL (Kirchhoff's Voltage Law) the sum of voltage raise at any close circuit is equal to sum of voltage drop in that circuit. In such case the port relationship of the two individual networks will be modified by interconnection and violated and hence the addition of impedance parameters will not be valid for the overall network. The following concept is performed in MATLAB simulation.

III (A). SIMULATION CIRCUITS AND OUTPUT WAVEFORMS OF SERIES CONNECTION

I. Series Connected Two Port Network (T-Networks-Not correct Combination)

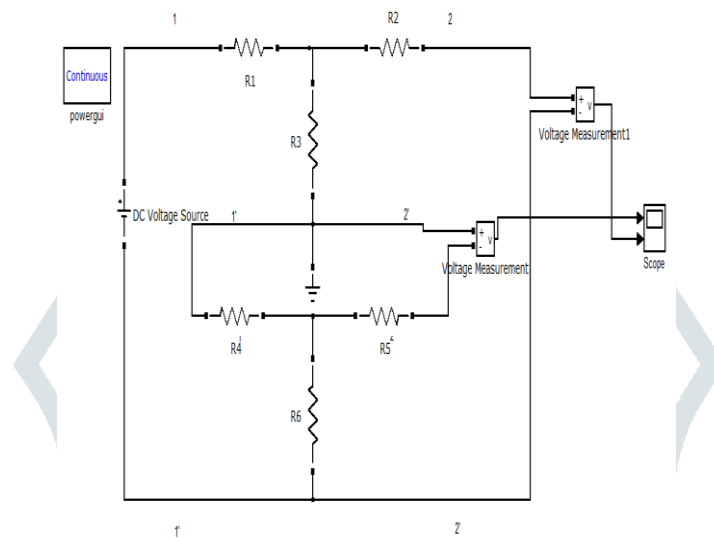

Figure 3. Simulation Circuit for Series Connected Two Port Network (T-Networks) (Not correct Combination)

As shown in the above figure two T-Networks are connected in series configuration. Where, the voltmeters to measure voltage between two networks are connected as shown in the figure.

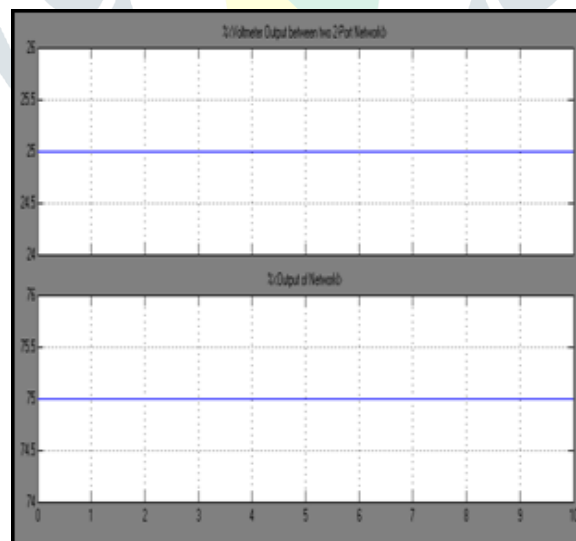

Figure 4. Output Waveforms for Series Connected Two Port Network (T-Networks) (Not correct Combination)

Output waveforms shows that the voltage between ground of one network and terminal of other network is present, so It violate the KVL (Kirchhoff's Voltage Law).

II. Series Connected Two Port Network (T-Networks- Correct Combination)

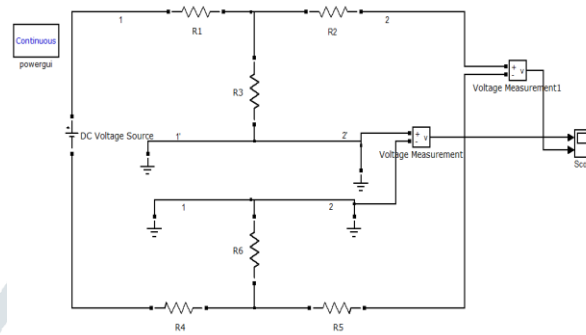

Figure 5. Simulation Circuit for Series Connected Two Port Network (T-Networks)

As shown in the figure above two T-Networks are taken where the value of each resistance is 10Ω and the source voltage is 100V. The simulation is performed by connecting two networks in series.

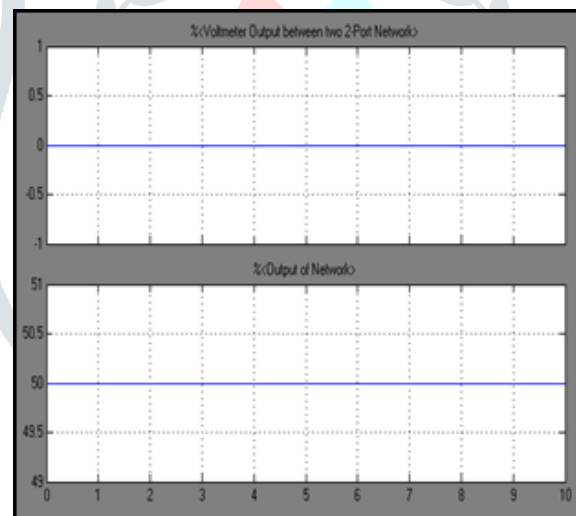

Figure 6. Output waveforms for Series Connected Two Port Network (T-Networks)

Output waveforms performed in MATLAB simulation. The first waveforms shows the output of voltmeter which is connected between two T-Networks. If it's reading is zero than two networks are connected in series combination which is permissible.

III. Experiment for Series Connected Two Port Network (Not Correct Combination)

Two individual networks are connected in series connection. Voltmeter is connected on another side of network, if the connection is not correct then circulating current is start to flow and so that the voltage drop present which makes KVL not satisfied.

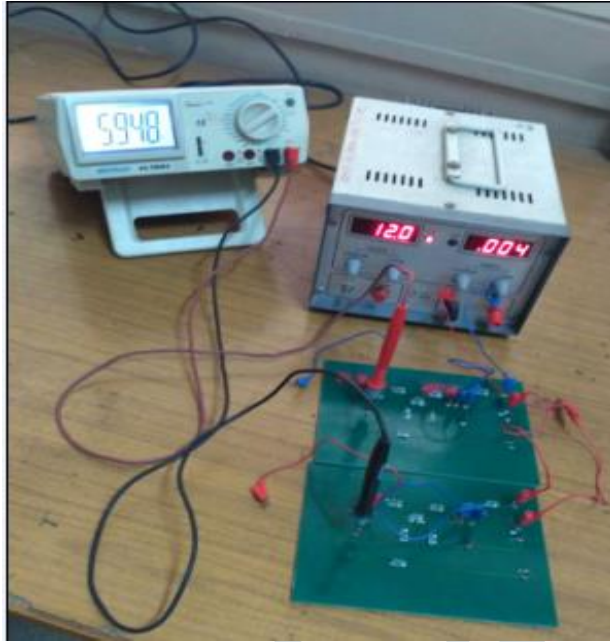

Figure 7(A)

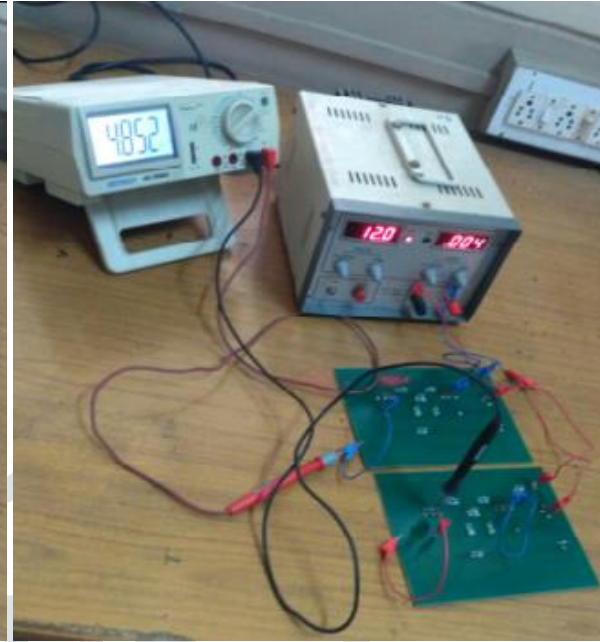

Figure 7(B).

Figure 7: Experiment for Series-series Connection of Two Port Network (Not Correct Combination)

IV. Experiment for Series Connected Two Port Network (Correct Combination)

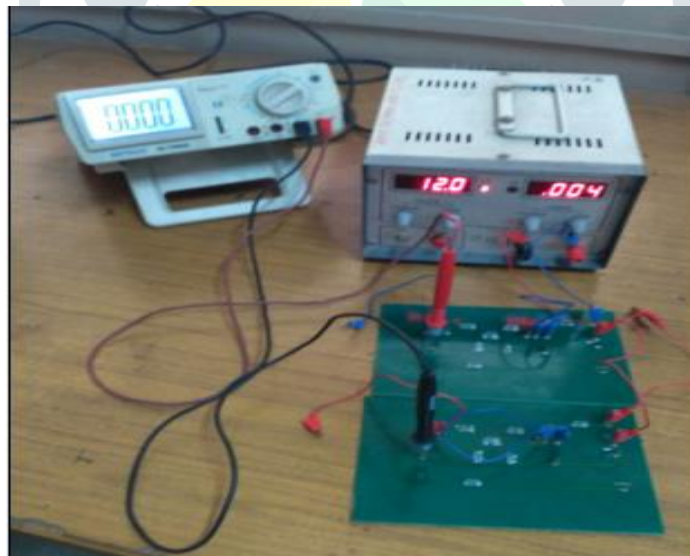

Figure 8. Experiment for Series-series Connection of Two Port Network (Correct Combination)

Here The two networks are connected in series combination. If the voltage between them is zero means that KVL satisfied completely.

IV. CONCLUSION

This paper has included the details of interconnection of two individual Two-Port networks. We can connect them in different configuration moreover for each connection respected parameter is used for mathematical calculation. Moreover we can conclude the following points based on simulation results and also from the performed experiment.

- When two different Two -Port network are connected in Series KVL (Kirchhoff's Voltage Law) must be satisfied.
- Simulations performed in MATLAB where correct and not correct combination is discussed with output waveforms.
- Experimentally also series connection of two port networks are discussed. As per the experimental results if the connections are wrong then Voltage must be present results in summation of total voltage around any closed circuit becomes not equal to zero. Thus for correct combination KVL must be fulfilled and it's proved by experimental results.

The application of different connection of two port network in power system using different configuration in connection desired output can be obtained.

For future works simulation can be performed on combination of dependent and independent sources moreover the circuit can be figure out using non linear elements with non linear loads for different connections.

V. ACKNOWLEDGEMENT

Authors would like to thank Department of Electrical Engineering and specifically Lab In charge and supporting staff for providing necessary support for taking data and experimental work.

VI. REFERENCES

- [1] U.A.Patel, "Circuits and Networks", Mahajan Publishing House,(1-1332),10th Edition-2015
- [2] http://enr.case.edu/merat_francis/eecs397/Two-port%20Networks.pdf
- [3] M.S.Sukhija, T.K.Nagsarkar, "Circuits and Networks", Mahajan Publishing House, (1-1000),2nd Edition-2016