

An Appraisal on PID Supervisor Change Consuming Current Computational Procedures

¹Name of 1st Mr Mahendrasinh Chauhan

¹Designation of 1st Assistant Professor

¹Name of Department of 1st Faculty of Engineering

¹Name of organization of 1st Gokul Global University, Sidhpur, Patan, Gujarat – India

Abstract

proportional-integral-derivative (PID) controllers are widely employed in engineering practises because of their simple designs, resistance to model errors, and ease of operation. There are several PID controllers available nowadays. Intelligent regulators with features for automatically adjusting PID parameters have been developed by companies. The techniques reviewed are classified into classical techniques and computational techniques developed for PID tuning.

Key words: PID Controllers; Tuning; Classical Techniques; Classical Techniques and Intelligent Computational Techniques

Introduction

Feedback control methods have had a significant influence in the sectors of manufacturing, robotics, aviation, and process control throughout the years. Aside from the proportional-integral-derivative (PID) controller, other efficient, robust, and adaptive controllers have been proposed. PID controllers, on the other hand, have unparalleled acceptance and repute in control systems. PID controllers date back to the governor design of the 1890s. Despite being around for a long time, PID controllers are still used in the majority of industrial applications. According to a 1989 survey, 90% of process industries employ them. PIDs are widely used in industry because to their simplicity and ease of online re-tuning. [2] Despite these benefits, PID controllers have numerous drawbacks, including undesirable speed overshoot and slow response as a result of unanticipated variations in load torque and sensitivity to controller increases. Controller tuning has long been recognised as a crucial feature of feed-back controllers. As a result, controller tuning has become a significant field of research in both academia and industry.

Control engineering is concerned with the research and investigation of dynamic systems in order to develop efficient, reliable, and promising controllers. Furthermore, disadvantages of PID control approach for nonlinear systems include: difficulties in selecting appropriate and proper controller gains, and the procedure known as tuning. Automatic tuning is proposed in [3] and most typical obstacles are in selecting appropriate controller gains; if set too low, the control aim may never be met. The majority of PID tuning strategies described in the literature are heuristic and do not guarantee optimal performance. The Ziegler-Nichols [4] tuning technique is a famous textbook tuning method with a simple yet winding algorithm. It works by first raising the proportional gain until the system becomes unstable, then scaling back by 20% and modifying the integral and derivative terms using a proposed technique.

Meanwhile, as people's expectations for quality control have grown more stringent, flaws in ordinary PID control have progressively become apparent. For time-varying items and nonlinear systems, conventional PID control is rarely successful. As a result, ordinary PID control is severely constrained. As a result, it has been enhanced in a variety of ways, the most of which are summarised in [5]. On the one hand, routine PID is fundamentally enhanced; on the other hand, among current intelligent controls, fuzzy control, neural network control, and expert control are the most active.

The other sections of this review paper are summarized as architecture of PID controller in section II, section III gives the classification of PID controller tuning.

Classification of PID Controller Tuning

These techniques can be broadly classified as classical and computational or optimization techniques as shown in figure.

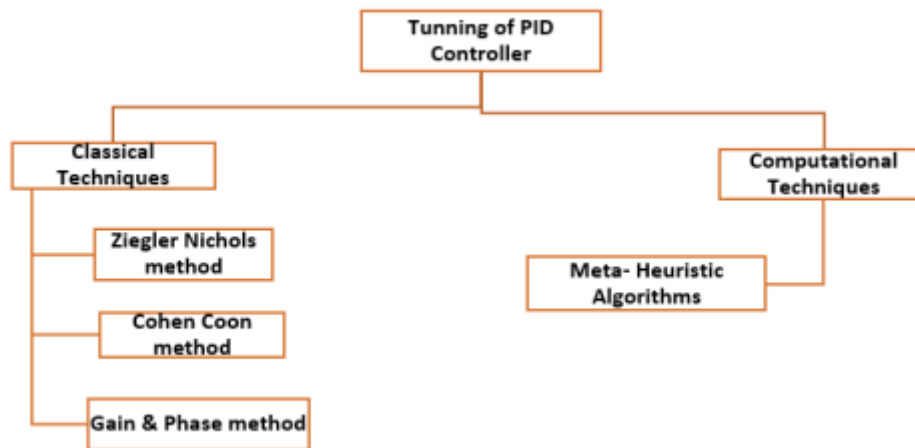

PID Controller Tuning Classification

Classical Techniques

Classical procedures establish assumptions about the plant and the intended output and attempt to get some aspect of the process analytically or visually, which is then utilised to determine controller settings. These strategies are computationally very quick and easy to implement, and are suitable for initial iteration. However, due to the assumptions made, the controller settings do not always produce the expected results, and extra tuning is necessary.

Ziegler Nichols Method

This is by far the most often used tuning approach. It was introduced in 1942 by John Ziegler and Nathaniel Nichols and is still a basic, fairly effective PID tuning approach today. Ziegler and Nichols have presented two techniques. Ziegler and Nichols performed several investigations and suggested guidelines for determining K_P , K_I , and K_D values based on the transient step reaction of a plant. They demonstrated two approaches: closed-loop and openloop. The ZN tuning technique is used to get process fundamentals such as process gain (K_P), process time constant (T_p), and process dead time (L_p). Ziegler and Nichols proposed utilising different K_P , T_I , and T_D values for closed and open loops. [6] PID controllers for spindle motor systems were tuned using this technology. The Ziegler and Nichols approach was the first to be developed, and it is based on specific controller assumptions. As a result, more tuning is always required, because the controller settings produced are fairly aggressive, resulting in excessive overshoot and oscillatory response.

Cohen Coon Method

Cohen and Coon (Cohen, 1953) proposed a method for obtaining PID controller settings using the First Order Plus Time Delay (FOLPD) model. The reduction of load turbulence is a critical design criterion. [7] The controller parameter configuration is described in (Cohen, 1953). Regardless having a superior model, the Cohen and Coon strategy produces results that are not much better than the Ziegler Nichols approach.

Gain and Phase Method:

Astrum and Hägglund (1984) proposed a test that was a substantial advance over the ZN test in terms of simplicity of use in automated loop tuners. They proposed replacing the variable proportional gain with a nonlinear function based on relay nonlinearity. In [8] developed a gain and phase method for obtaining particular points on the Nyquist curve to help in setting controller pre tuning parameters in order to overcome the Z-N technique's trail by error constraint. The tuning approach is based on the ability to change the process Nyquist curve's critical point to a specific place.

Computational Techniques

There are six (6) commonly used cost functions for adjusting PID controller settings. These are some of the most widely used cost functions:

(1). Mean Square Error

$$\text{MSE} = \frac{\int_0^t e(t)^2}{t}$$

(2). Integral Error

$$\text{IE} = \int_0^t e(t)$$

Metaheuristic Algorithms

Metaheuristics have grown in popularity in recent years because to its efficiency and efficacy in tackling large and complex problems. [9] Metaheuristics are types of heuristics that outperform basic heuristics. "Beyond" or "higher level" are implied by the term "meta."

Randomization frequently produces unexpected outcomes. Regardless matter whether metaheuristics are acknowledged, there is no standard or verifiable definition of heuristics and metaheuristics in the literature. Many academics and researchers use the terms heuristics and metaheuristics interchangeably. However, current findings appear to apply to any stochastic algorithms that employ randomization and global exploration as metaheuristics. This evaluation will follow the same format.

Computational and Intelligent Techniques Tuning Methods

Because of the use of microprocessors in the controller, several researchers tweaked and tuned the control algorithm to get the desired result. This resulted in increased controller efficiency and the creation of more efficient and cutting-edge tuning approaches [10]. This also allows us to take use of the processing power and hence incorporate complex algorithms including cutting-edge approaches such as machine learning, neural networks, genetic algorithms, deep learning, and several other optimisation methods.

Particle Swarm Optimization Method

The approach is based on swarm intelligence, which is exhibited by some birds and fishes. This is an iterative process in which the algorithm attempts to discover the best answer possible based on given quality metrics. It is a computational intelligence approach utilising evolutionary computing. The author employed an internal model control (IMC)-based technique in [11], in which the PID controller is adjusted using a single tuning parameter. This parameter is known as the IMC filter coefficient. With longer time delays, this method produces a superior answer [18]. The author demonstrated a comparison of traditional Z-N tuning and the PSO algorithm in [12], demonstrating that PSObased tuning produced improved step response performance.

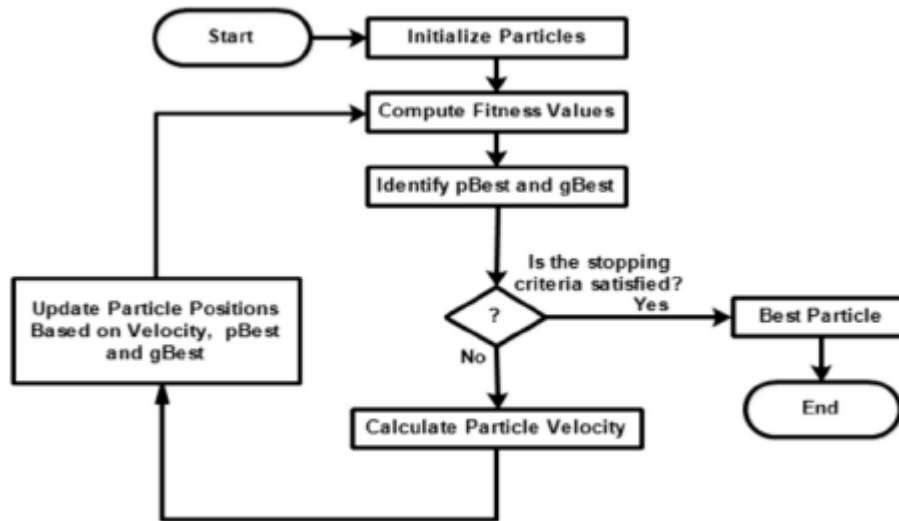

Flow diagram of PSO

The basic flow diagram of PSO is shown in figure.

Genetic Algorithm

A genetic algorithm (GA) is a search algorithm that traverses the search space in a way similar to natural evolution. It uses probabilistic criteria to find and modify probable solutions in the search space, and it employs a cost function to assess the fitness of solutions. GA demands that the solution be represented in a fashion that is equivalent to genes so that the mechanisms that cause gene changes (such as mutation) may be applied. Typically, this is accomplished by expressing the solutions in binary form. [13] GA is very popular in PID tuning, and has gained wide applications in control systems. Fig. shows the standard genetic algorithm flowchart.

→ Selection, during each iteration, a proportion of solutions is selected, based on the fitness function. → Reproduction, selected solutions are paired up and crossover and mutation operation are performed to get the next generation of solutions. → Termination, the iterations are terminated when the termination condition time or accuracy is reached.

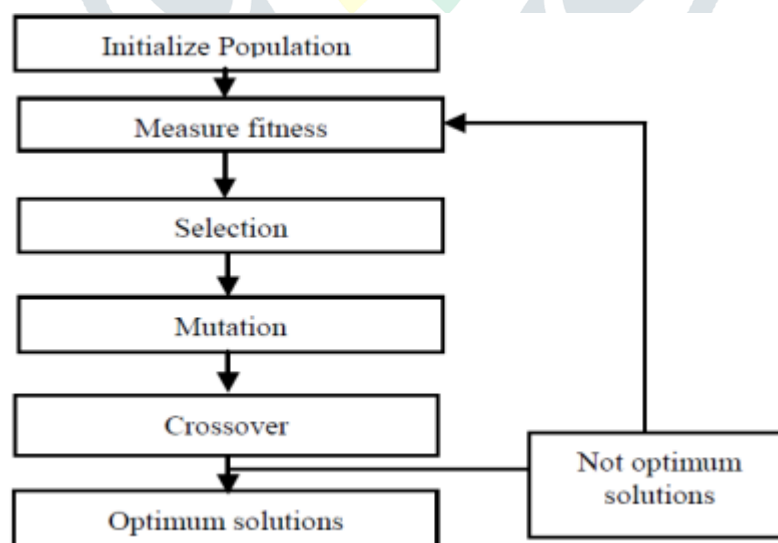

Artificial Neural Networks

An Artificial Neural Network (ANN), is a mathematical model or computational model that tries to simulate the structure or functional aspects of biological neural networks. Most ANNs are adaptive systems that modify their structure based on external or internal information that travels through the network during the learning period. Though ANN can model even highly nonlinear systems, it is not used in control due to its

limited applicability in PID controllers [16], in part because neural network control design has some drawbacks due to some inherent shortcomings of ANN theory, such as the number of layers and the number of neurons per layer being difficult to determine. Fig. shows the ANN based PID controller tuning.

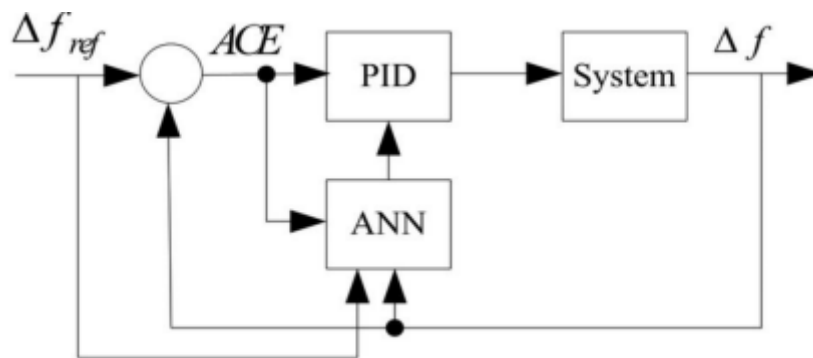

PID tuning using ANN

A finite horizon optimal control problem is solved on-line, permitting to calculate the tuning parameters of the PID controller. [17] The proposed method is implemented on a level-flow pilot plant and a comparison with conventional auto-tuning methods is also given.

Fuzzy logic control

Fuzzy control laws are established for adaptive tuning of control parameters by regulating parameter errors E and fluctuations in errors E_c to fulfil the requirements for E and E_c parameters in various control periods. According to fuzzy set theories, functional linkages between K_P , K_I , K_d , and error changes EC are created for fuzzy PID control algorithms. At present, there have been some common fuzzy PID controllers such as fuzzy PI controllers, fuzzy PD controllers, fuzzy PI +D controllers, fuzzy PD + I controllers, fuzzy (P + D) 2 controllers, and fuzzy PID controllers.

Machine Learning

This paper [23] seeks to show a machine learning approach using multivariate regression with gradient descent and the normal equation. This study describes the initial phase in the automated adjustment of PID parameters using regression model learning data. This method may be applied to data-rich process plants and electromechanical systems that generate enough data for supervised learning. Fig. shows the Machine learning Based PID controller tuning using Data driven system.

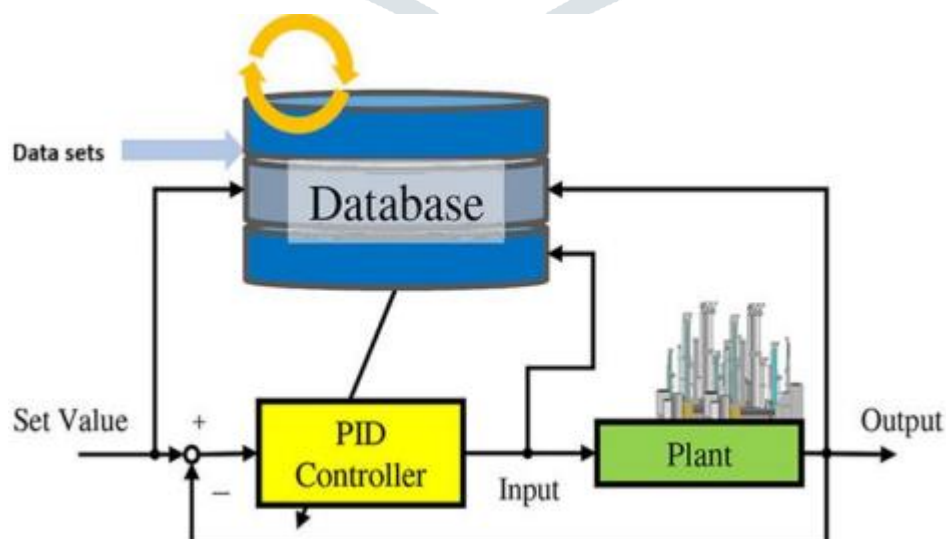

The data-driven (machine learning) approach is gaining popularity and establishing itself as a formidable tool in control system design; this study demonstrates how the methodology may be used to drive PID

tuning parameters via data. Deep learning takes over when gradient descent and normal equation forms are insufficient for analysis since they provide a more accurate brain-like mode of data transfer with back propagation error-correcting procedures. The fundamental concept is to train a model and collect enough learning data to self-tune PID settings using a rapid looping technique.

Deep Reinforcement Learning

The deep reinforcement learning algorithm that we used to train the PID controller in this paper is deep deterministic policy gradient, which is very suitable to solve the continue action control problem. [24] design an algorithm named with DRPID that combine common PID algorithm with deep reinforcement learning, outperforms the classical PID algorithm very much. The core idea behind our technique is to use DRL to train an agent to produce PID parameters based on the current state, as seen in Fig. When the agent outputs suitable parameters, the PID controller will control the actor well, and it will receive a higher reward as encouragement; otherwise, it will receive a lower reward as punishment. As the agent is trained, the parameters output by the agent will gradually converge to the optimal value.

Advantages and Disadvantages of PID Controller Tuning Classification based on classical techniques and computational techniques are summarized.

Conclusion

A major research focus is on successfully employing PID controllers to control complicated things. This research examined a wide range of strategies for PID tuning. Following a brief overview of the approach, a discussion of the work done in tuning PID controllers employing both the classical techniques and Computational or Intelligent techniques was presented along with its Pro's and Con's. This study's purpose and aspiration is for academics and students to utilise it as a springboard or basis for qualitative research in this sector.

References:

- 1.S. Bennett, "Nicholas Minorsky and the Automatic Steering of Ships," IEEE Control Systems Magazine, vol. 4, no .4, pp. 10–15, 1984.
2. Kushwah, M., Patra, A., 2014. Tuning PID controller for speed control of DC motor using soft computing techniquesa review. Adv. Electron. Electr. Eng.4, 141–148.
3. K. J. Åström and T. Hägglund, Automatic tuning of PID controllers. Instrument Society of America (ISA), 1988.
4. J. G. Ziegler and N. B. Nichols, "Optimum settings for automatic controllers," trans. ASME, vol. 64, no. 11, 1942.
5. Yi Zhou " A Summary of PID Control Algorithms Based on AI-Enabled Embedded Systems" Security and Communication Networks Volume 2017, Article ID 7156713, 7 pages <https://doi.org/10.1155/2017/7156713>
6. C. S. Soh, C. Bi and K. C. Chua, "Direct PID Tuning For Spindle Motor Systems," Asia-Pacific Magnetic Recording Conference, Singapore, pp. 1-2, Nov-Dec.2006.
7. G. H. Cohen, and G. A. Coon, "Theoretical considerations of retarded control," Transactions of ASME, vol. 75, pp. 827-834, 1953.
8. Åström, K.J., Hägglund, T., 1984. Automatic tuning of simple regulators with specifications on phase and amplitude margins. Automatica20, 645–651.
9. Talbi, E.-G., 2009. Metaheuristics: from Design to Implementation, vol.74. John Wiley & Sons.
10. Åström, K.J., Hägglund, T.: PID Controllers: Theory, Design and Tuning. Instrument Society of America, USA (1995)
11. Vincent, A.K., Nersisson, R.: Particle swarm optimization based PID controller tuning for level control of two tank system. IOP Conf. Ser.: Mater. Sci. Eng. 263, 052001 (2017). <https://doi.org/10.1088/1757-899x/263/5/052001>, 14th ICSET-2017
12. Solihin, M.I., Tack, L.F., Kean,M.L.: Tuning of PID controller using particle swarm optimization (PSO). In: Proceeding of the International Conference on Advanced Science, Engineering and Information Technology (2011).
13. S. M. G. Kumar, R. Jain, and N. Anantharaman, "Genetic Algorithm Based PID Controller Tuning for a Model Bioreactor," Indian Chemical Engineer, vol. 50, no. 3, pp. 214-226, 2008.
14. Patil, N., Lakhekar, G., 2017. Design of PID controller for cascade control process using genetic algorithm. In: 2017 International Conference on Intelligent Computing and Control Systems. ICICCS. IEEE, pp.1089–1095.
15. Amaral, J.M., Tanscheit, R., Pacheco, M.A., 2017. Tuning PID controllers through genetic algorithms. Complex Syst.2, 3.
16. DOLEŽEL, Petr, MAREŠ, Jan, "Self-tuning PID Control using Genetic Algorithm and Artificial Neural Networks," ASR

2009 Instruments and Control, pp. 33- 39, 2009. 17. Corneliu Lazar, Sorin Carari, Draguna Vrabie, Marius Kloetzer, “Neuro-predictive control based self-tuning of PID controllers,” Proceedings of European Symposium on Artificial Neural Networks, pp. 391-396, 2004. 18. L. Xue, Y. Liu, E. Zhu, and X. Ma, “Design of intelligent fuzzy- PID temperature control systems,” Information Recording Material, vol. 19, no. 11, pp. 118–120, 2017. 19. Z. Guo, H. Yu, and L. Chen, “High-speed galvanometer motor control based on fuzzy PID,” Small & Special Electrical Machines, vol. 47, no. 4, pp. 1–5, 2014. 20. Jan Jantzen, Tuning Of Fuzzy PID Controllers, Technical Report No. 98-H 871 (fpid), Department of Automation, Technical University of Denmark, Denmark, 1998. 21. K. Lakshmi Prasanna , J. N. Chandra Sekhar, G. Marutheaswar “ Implementation of DTC in Induction Motor Using Anfis Pi Controller” 2017 IJSRSET ,Volume 4 Issue 4 ,Print ISSN: 2395-1990 ,Online ISSN : 2394-4099. 22. Dr.J.N.Chandra Sekhar D.Sai Swaroop “Comparison of Cascaded H-Bridge Multilevel Inverter connected to grid using PI and fuzzy logic controllers” International Research Journal of Engineering and Technology (IRJET) vol 9 Issue 12,Dec 2017. 23. Andrew Zulu “Towards Explicit PID Control Tuning using Machine Learning” IEEE Africon 2017 Proceedings. 24. Yunxiao Qin, Weiguo Zhang, Jingping Shi, Jinglong Liu “Improve PID controller through reinforcement learning”

