

# UNDERGROUND CABLE FAULT DISTANCE CONVEYED OVER GSM

Author:- Gyanendra Kumar  
Bachelor of Technology Electrical and Electronics  
Pranveer Singh Institute of Technology  
Kanpur, India

Co-Author:- Sameer Bhambri  
Bachelor of Technology Electrical and Electronics  
Pranveer Singh Institute of Technology  
Kanpur, India

Co-author:-Brijesh Kumar Dubey  
Bachelor of Technology Electrical and Electronics  
Pranveer Singh Institute of Technology  
Kanpur,India

## II. Techniques of Fault Location:

In general, fault location techniques for underground cable network can be categorized in two groups:

### 1. Tracer method:

The tracer method is an exhaustive way of locating a faulted segment by “walking” through the cable circuits. A faulted segment can be determined by audible or electromagnetic signals and requires dispatching crew members to the outage area. There have been various techniques largely used in the industries, including the tracing approach through acoustic, electromagnetic or current.

### 2. Terminal method:

The terminal method is a technique used to determine a fault location of a distribution cable network from one or both ends without tracing exhaustively. A bridge technique is one of the most popular terminal methods that links with a resistor to determine a fault location. It is a technique used to detect fault location of cable from one or both ends without tracing. This method use to locate general area of fault, to expedite tracing on buried cable.

Fodt Sensor (Fiber Optic Distributed Temperature Sensor) To Fault Detection of Xlpe Insulated Underground Cable the FODT sensor, which is applied to fault detection of XLPE insulated underground cable in resistance grounded power system, can find fault point immediately.

If a fault occurs in an underground power cable it is necessary to find the fault point as quickly and accurately as possible. Although Murray loop method and pulse radar method have been extensively used for cable fault locating, the fault line needs to be removed from service and connected to detection equipment, which will take much time and effort. In the present paper, a new fault location method, which integrates fiber optic distributed temperature (FODT) sensor into cable, is introduced.

## III. Principles of Fodt Sensor:

## ABSTRACT:

This paper proposes a fault location model for underground power cable using microcontroller. The aim of this project is to determine the distance of underground cable fault from the base station in kilometers. This project uses the simple concept of ohm’s law. If any fault like open circuit occurs, voltage drop will vary depending on the length of fault in cable, thus the current varies.

## I. INTRODUCTION:

Underground cables have been widely implemented due to their reliability and environmental concerns. To improve the reliability of any distribution system accurate identification of a faulted segment is required in order to reduce the interruption time during fault, i.e., to restore service by determining a faulted segment in a timely manner, In the conventional way of detecting a fault, an exhaustive search in larger-scale distance has been conducted. This is time-consuming and inefficient, Not only that the manpower resource is not utilized. But also the restoration time may vary depending on the reliability of the outage information. As such, deriving an efficient technique to locate a fault can improve system reliability.

Use of underground power cable is expanding due to the reason that safety considerations and enhanced reliability in the distribution and transmission systems in recent times. Due to the safety reasons and high power requirements in populated areas, use of underground cable has seen a sharp hike in recent days .Till last decade cables were made to lay overhead & currently it is lay to underground cable which is superior to earlier method. Because the underground cable are not affected by adverse weather condition such as storm, snow, heavy rainfall as well as pollution. But when any fault occur in the cable, then it is difficult to locate fault. So we will move to find the exact location of fault.

Fiber optic distributed temperature (FODT) sensor, which is used for fault detection in XLPE insulated Underground cable, is one of functional type optic fiber sensors. The principle of FODT sensor is based on the intensity of the Raman back-scattering light varies

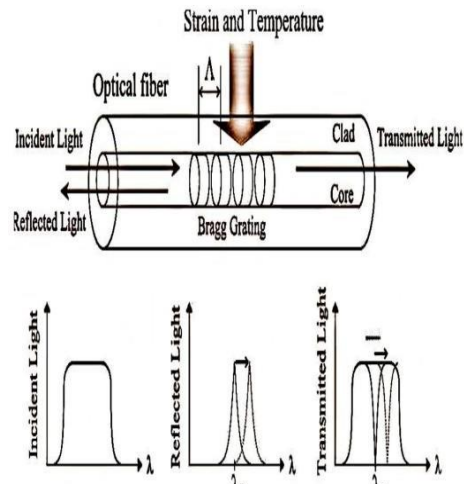

Learning and Operation modes in a Neural Network:

In learning mode neural network is trained from input-output data pairs. Learning actually indicates adaptation of variable weights between nodes of all layers. First, the training data that simulate various transient behaviors of transmission lines are modeled by EMTP package. The next stage is the operation after learning.

**IV. Structure of Proposed system:**

Input Layer:- The number of nodes in the input layer are Four three phases (a, b, and c) and zero phase. The normalized RMS value of the three-phase and the zero-phase current values are used as inputs in the input layer.

**1. Hidden Layer:**

The number of hidden-layer units turns out to be twenty out of the trials with four, ten and twenty nodes. The network with twenty hidden-layer units product the best value among other two cases in terms of the smaller error between target and actual values of the Output nodes.

**2. Output Layer:**

Output-layer units corresponds to the four phase currents, hence the number of output- layer units are four. Combination in the training data of the four output nodes assign to the fault types and as well as the normal type.

**V. Block Diagram Of Underground Cable Distance Conveyed Over Gsm:**

The project uses the simple concept of OHMs law where a low DC voltage is applied at the feeder end through a series resistor. The current would vary depending upon the length of fault of the cable in case there is a open circuit of LL or 3L or LG etc. The series resistor voltage drop changes

accordingly which is then fed to an ADC to develop precise digital data which the programmed microcontroller would display the same in Kilo meters. The project is assembled with a set of resistors representing cable length in KMs and fault creation is made by a set of switches at every known KM to cross check the accuracy.

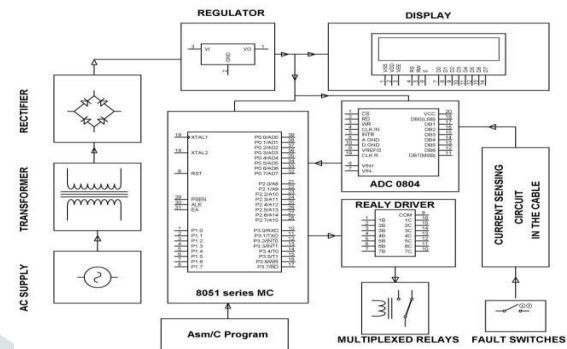

Fig.3underground Cable Distance Conveyed Over Gsm

This is proposed model of underground cable fault distance locator using microcontroller. It is classified in four parts – DC power supply part, cable part, controlling part, display part. DC power supply part consist of ac supply of 230v is step-down using transformer, bridge rectifier converts ac signal to dc & regulator is used to produce constant dc voltage. The cable part is denoted by set of resistors along with switches. Current sensing part of cable represented as set of resistors & switches are used as fault creators to indicate the fault at each location. This part senses the change in current by sensing the voltage drop. Next is controlling part which consists of analog to digital convertor which receives input from the current sensing circuit, converts this voltage into digital signal and feeds the microcontroller with the signal. The microcontroller also forms part of the controlling unit and makes necessary calculations regarding the distance of the fault. The microcontroller also drives a relay driver which in turn controls the switching of a set of relays for proper connection of the cable at each phase. The display part consists of the LCD display interfaced to the microcontroller which shows the status of the cable of each phase and the distance of the cable at the particular phase, in case of any fault.

**VI. Algorithm:**

- Step1: Initialize the ports, declare timer, ADC, LCD functions.
- Step2: Begin an infinite loop; turn on relay 1 by making pin 0.0 high.
- Step3: Display “R:” at the starting of first line in LCD.
- Step4: Call ADC Function, depending upon ADC output, displays the fault position.
- Step5: Call delay. Step6: Repeat steps 3 to 5 for other two phases.

**VII. Power Supply:**

The power supply circuit consists of a step-down transformer which is 230v step down to 12v. In this circuit 4 diodes which are used to form bridge rectifier which delivers pulsating dc voltage & then fed to capacitor filter the output voltage from rectifier is fed to filter to eliminate AC components present even after rectification. The filtered DC voltage is given to regulator to produce a 12v constant DC voltage.

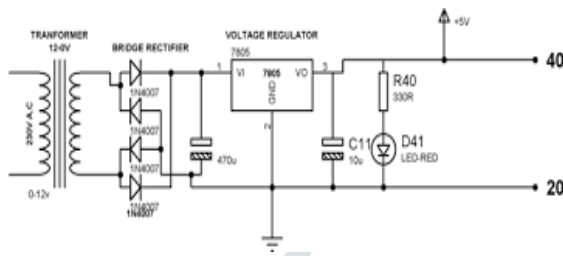

FIG.4 POWER SUPPLY

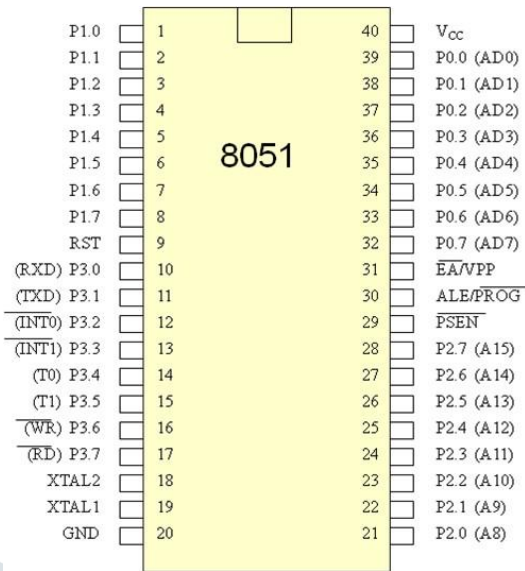

FIG.3 8051 MICROCONTROLLERS

**1. Rectifier:**

The output of the transformer is fed to the rectifier. It converts A.C. into pulsating D.C. The rectifier may be a half wave or a full wave rectifier. In this project, a bridge rectifier is used because of its merits like good stability etc. The circuit has four diodes connected to form a bridge.

A rectifier is an electrical device that converts an alternating current (AC), which periodically reverses direction, to direct current (DC), which flows in only one direction. The process is referred to as rectification.

Rectifiers have many uses, but are often found serving as components for DC supplies and high-voltage direct current power transmission systems. Rectification may also serve in roles other than to generate direct current for use as a source of power.

**2. Voltage Regulator:**

A voltage regulator is an electrical regulator designed in order to automatically maintain a constant voltage level. In this project, power supply of 5V and 12V are required. In order to obtain these voltage levels, 7805 and 7812 voltage regulators are used. The first number 78 represents positive supply and the numbers 05, 12 represent the required output voltage levels. The L78xx series of three-terminal positive

FIG.6 VOLTAGE REGULATOR

Electronic voltage regulators are found in various devices such as computer power supplies where they stabilize the DC voltages used by the processor and other elements. In automobile alternators & central power station generator plants, voltage regulators controls the output of the plant. In electric system, voltage regulators may be installed at a substation or along distribution lines so that all customers receive a steady voltage independent of how much power is drawn from the line.

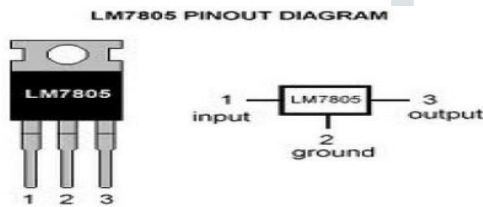

**VIII. 8051 Microcontroller:**

8051 is an 8-bit family of microcontroller developed by Intel in 1981. This is one of the most popular family of microcontroller being used all across the world. This microcontroller was also referred to as “system on a chip” because it has 128 bytes of RAM, 4Kbytes of ROM, 2 Timers, 1 Serial port, and four ports on a single chip. The CPU can only work for 8bits of data at a time because 8051 is an 8-bit processor. In case if data is larger than 8 bits then it has to be broken into parts so that the CPU can process conveniently. Most manufacturers have put 4Kbytes of ROM even though the quantity of ROM can be exceeded upto 64 K bytes.

### 3. Relay:

Relay is sensing device which senses fault & send a trip signal to circuit breaker to isolate the faulty section. A relay is automatic device by means of which an electrical circuit is indirectly controlled & is monitored by change in the same or another electrical circuit. There are various types of relays: Numerical relay, Static relay & electromagnetic relay. Relay are housed in panel in control room.

### 4. Advantages:

It requires less maintenance

Higher efficiency

Less fault occur in underground cable

Underground cable fault location model is applicable to all types of cable ranging from 1kv to 500kv&other types of cable fault such as-Open circuit fault, cable cuts, Resistive fault, Sheath faults, Water trees, Partial discharges.

### IX. Conclusion:

In the paper detect the exact location of open circuit fault in the underground cable from feeder end in km by using

### References:

- [1]. T. Kawai , N. Takinami , T. Chino , K. Amano , K. Watanabe , Y. Nakamura and N. Shiseki, "A New Approach to Cable Fault Location Using Fiber Optic Technology", IEEE Transaction on Power Delivery, vol. 10, no. 1, pp. 85-91, 1995.
- [2]. M.-S. Choi , S.-J. Lee , D.-S. Lee and B.-G. Jin, "A new fault location algorithm using direct circuit analysis for distribution systems", IEEE Trans. Power Del., vol. 19, no. 1, pp. 35-41, 2004
- [3]. M.-S. Choi, D.-S. Lee, and X. Yang, "A line to ground fault location algorithm for underground cable system," KIEE Trans. Power Eng., pp. 267–273, Jun. 2005.
- [4]. B. Kasztenny, I. Voloh, C.G. Jones, and G. Baroudi, "Detection of Incipient Faults in Underground Medium Voltage Cables," 61st Annual Conference for Protective Relay Engineers, pp. 349-366, April 1-3, 2008.

microcontroller8051. For this simple concept of OHM's law is used so that fault can be easily detected and repaired.

FODT sensor is used in fault detection of cable lines is Suitable to a low resistance grounded system, long distance line and multi-circuit line. The maximum detectable distance is 10 km with the accuracy and the time needed is approximately 15-30sec. A neural network-based fault identification system for underground transmission systems. Back propagation learning algorithm was used for training of the system and the number of units in the hidden layer, learning Rate and momentum were found by brute-force trials for optimum parameters.

### X. Future Scope:

In this project of detection only the location of open circuit fault in under ground cable line ,detects the location of open circuit fault, to detect the open circuit fault capacitor used in ac circuit which measure the change in impedance & calculate the distance of fault. For future research, proceed with similar neural networks structure for the fault section and fault location estimation.