

FAILURE ANALYSIS OF EXHAUST SYSTEM OF DIESEL ENGINE USING SOLIDWORKS MODELLING

¹Sinha Yashpalsinh L., ²Prof. Imran Molvi

¹P.G. Student, ²Associate Professor

Department of Mechanical Engineering, Parul University, Vadodara, Gujarat, India²

Abstract : Exhaust emission is main reason of health problems now a days because about 71% of pollution is generated by the exhaust of vehicles only. Normally exhaust gases contains hydro carbons and carbon monoxides. This harmful gas can damage environment and health problems are generated. In this study the vibration and noise generated by the exhaust gases and exhaust noise is mainly focused. In this study the exhaust muffler vibration and backpressure analysis are carried out using solid works modelling.

Keywords: Exhaust, Exhaust system, Diesel engine, Solid works analysis.

I INTRODUCTION

US Patent is registered by Milton O. Reeves and Marshall T. Reeves of Columbus, Indiana of the Reeves Pulley Company on 11 May 1897 for the development of the exhaust muffler under the title "Exhaust muffler for internal combustion engines". US Patent Office application No: 582485. Muffler is not main part of the exhaust system used to reduce the pollution caused by the engine. It is used to reduce the noise and vibration caused by the exhaust gas pressure. The key functions of automotive engine exhaust system are to carry out hot noxious exhaust gases from engine to atmosphere and significantly attenuating noise output from the engine through muffler, quickly and efficiently.

Exhaust gases create the pulses coming out through manifold the pulses generate the back pressure and noise inside the muffler. Back pressure should be avoided by modifying the muffler design, but unfortunately some amount of back pressure is always present inside the engine this back pressure generated inside makes negative impact on engine causing the damage to the muffler and exhaust system assembly. In muffler the sound or noise is cancelled by the destructive interference of opposite phase and same frequency of the sound wave. This sound waves are trapped inside the muffler and cancel each other by overlapping the frequencies.

Many researchers have published papers for designing and modification in muffler assembly. C.P. OMARIARA GUHAN has studied the muffler design in CFD tool analysis for light motor vehicles by adopting the volume optimization method. [4] Several such exhaust systems that utilize various designs and construction methods:

1. Vector muffler - for larger diesel trucks, uses many concentric cones, or for performance automotive applications, using angled baffles to cause exhaust impulses to cancel each other out.
2. Spiral baffle muffler - for regular cars, uses a spiral-shaped baffle system
3. Aero turbine muffler - creates partial vacuums at carefully spaced out time intervals to create negative back pressure, effectively 'sucking' the exhaust out of the combustion cylinder. [5]

II. EXHAUST SYSTEM

An Automobile **exhaust system** is usually Pipe used to draw burned gases away after a controlled combustion process inside an engine. The entire system draws burnt gases from the engine and includes one or more **exhaust pipes**.

An exhaust system must be designed to carry out the flue gases to the environment at sufficiently low pressure and maximum noise cancellation. The exhaust system serves two main functions. It reduces the noise generated by the high-pressure gases. The other purpose is to funnel the exhaust safely away from the vehicle. exhausts produce six gases as emissions; of the six, three are toxic (CO, CO₂, NO_x). Exhaust emissions system is the only means of channelling those ham full fumes. These exhaust gases then pass through a catalytic converter which removes unhealthy elements including carbon monoxide and hydrogen monoxide which are converted into inert gases.

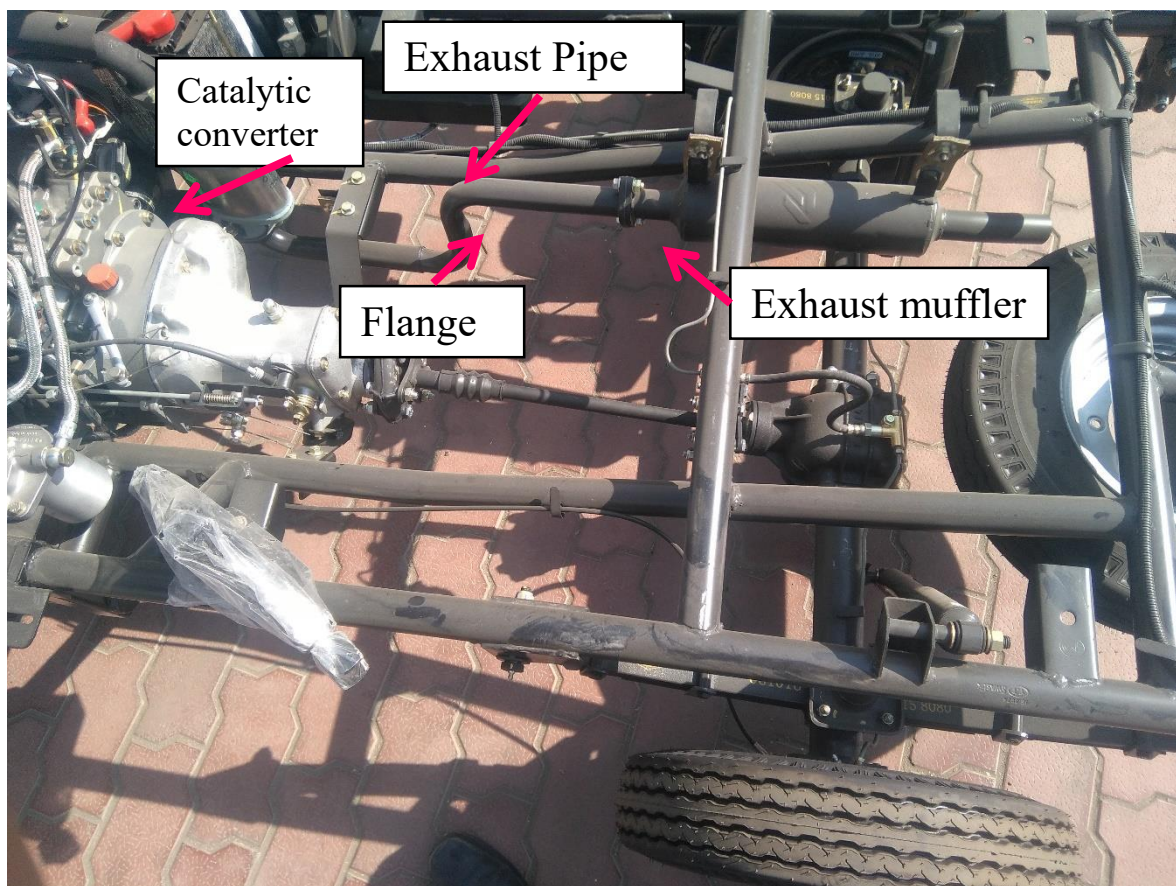

Fig.1:Figure 1 exhaust system assembly

Name	Specification
Inlet pipe dia	37 mm
Outlet pipe dia	37 mm
Number of holes	60 each
Distance between baffles	150 mm
Distance between baffles	150 mm
Overall length	300 mm
Material	Mild steel

Table 5 Notation Represents of Existing Muffler

III. OBSERVATION

From the field reports coming to Atul auto Ltd. It is found that the number of complaints is coming from the customers. Main parts of failure are related to muffler assembly. It is seen that muffler and exhaust pipe flange are getting broken in running condition. Another problem found from the field report is muffler bracket are getting damaged eventually damaging the muffler.

It is also found that due to the vibration un comfortable driving issues and jerks are also observed to the customers which is reducing the vehicle performance and market value in point of view to company.



Fig 2: Figure exhaust system engine assembly

IV. EXHAUST BACK PRESSURE [11]

Back pressure is the pressure exerted by the exhaust gas to overcome resistance of exhaust system. Muffler is designed to minimize the resonance developed by the exhaust gases by trapping them between platinum rhodium or platinum polonium plates. These plates restrict the free flow of the gases increasing the back pressure inside the exhaust system. [11]

Back pressure inside the exhaust system exerts inverse impact on the engine and damages the exhaust assembly for Light vehicles and small cargo vehicle. [8]

BACK PRESSURE LIMITS: [9]

Every engine has its own back pressure limit depending on the manufacturers design. After the specified back pressure limits of the engine more fuel consumption and reduction in efficiency is developed. Depending on the engine size the back-pressure values are shown in table:

Engine size (HP)	Back pressure limit
Up to 50	40 kPa
50 to 500	20 kPa
Above 500	10 kPa

Table 2: recommended back pressure limits [8,9]

V. FAILURE OF MUFFLER PARTS

From the field reports it is found that the number of muffler failure reports are coming to Atul auto Ltd. Are regarding the muffler and chassis failure from the m our research is concerned to muffler failure only.

Main muffler failure reports coming from the field are as below:

- 1) Muffler and exhaust pipe joining flange is getting separated causing the excessive noise coming from the engine.
- 2) Engine vibration is more at the idling speed of 1400 rpm in diesel engine.
- 3) Catalytic converter pipe is breaking near the flange side is also problem faced by the customers.
- 4) And, the bracket mounting the muffler to the chassis is also get broken.

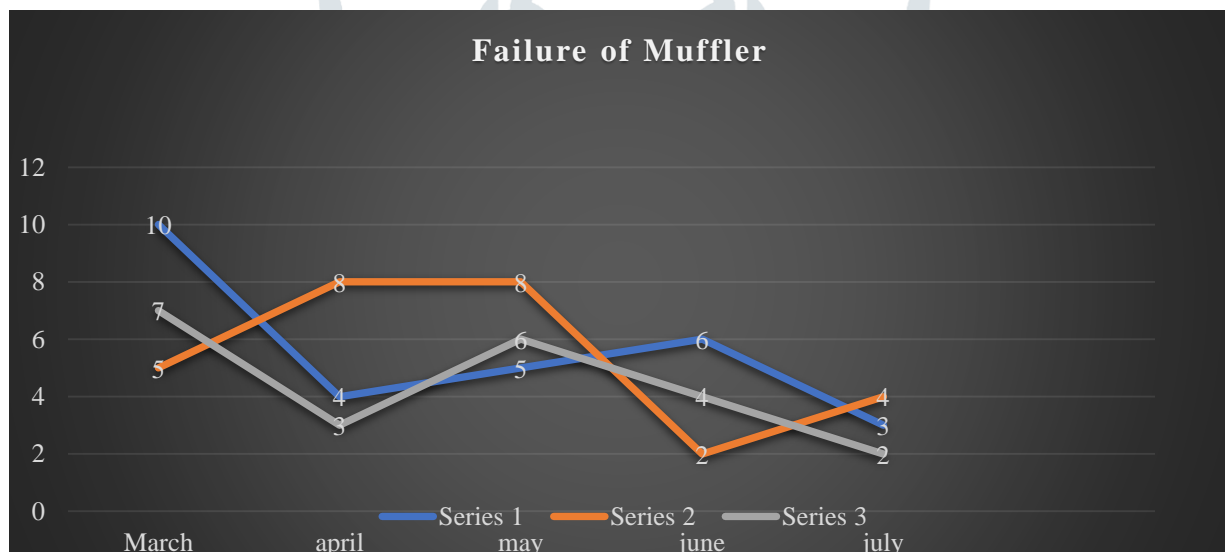

1. Chart 1 Failure of part V/S month

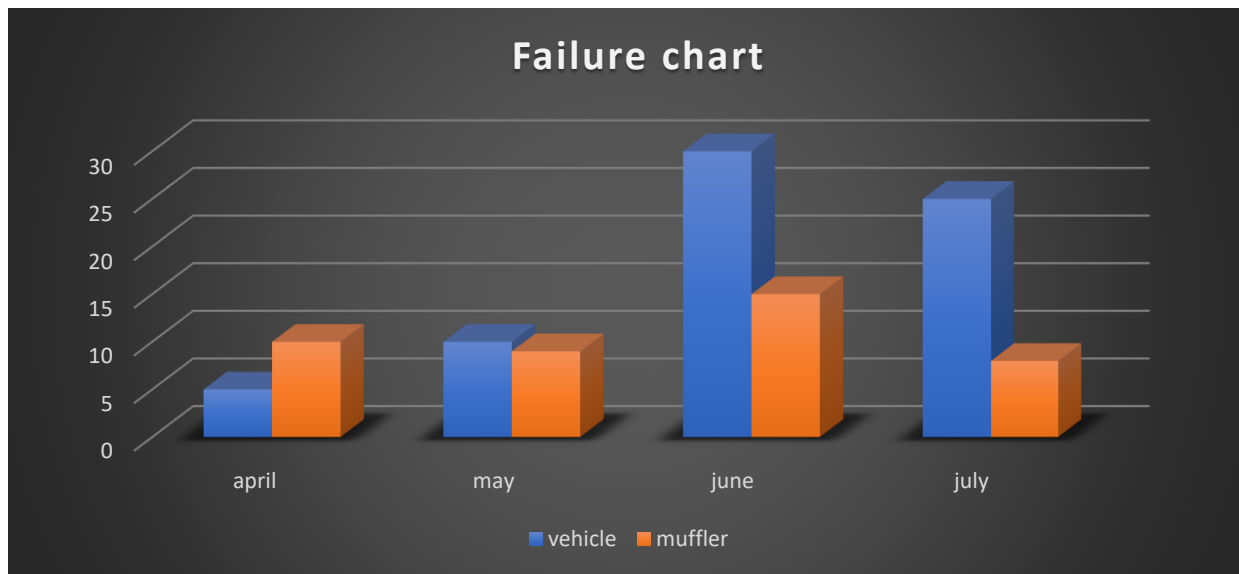

Chart 2. Total failure vs no. of vehicles

Out of the that the number of failure reports coming from the field during the month of march three different location the failure reports were 10,7,5 respectively. similarly, the number of failure reports from the different location are shown in chart. [9]

VI. SOLIDWORKS SIMULATION

1) **Thermal analysis:** From the field reports “Flash Reports” as discussed above the failure complains are coming from the customers are increasing day by day this research is carried out to reduce the exhaust failure and improve the life cycle on the part. Thermal analysis is carried out. Boundary condition for the analysis carried out in solid works simulation are 298 k temperature surrounding, inlet temperature of 850 and outlet temperature of 320 k is considered.

Name	Specification
Inlet pipe diameter	60
Type of muffler	Reactive
Outlet pipe diameter	36
Number of holes	60
Distance between baffles	150
Distance between baffles	100
Overall length	350
Material	Mild steel

Table 1. Specification of Muffler

Fig shows the pressure flow analysis from solid works simulation for the analysis carried out. This thermal variation is generally causing the expansion of metal and material get foul from the joints.

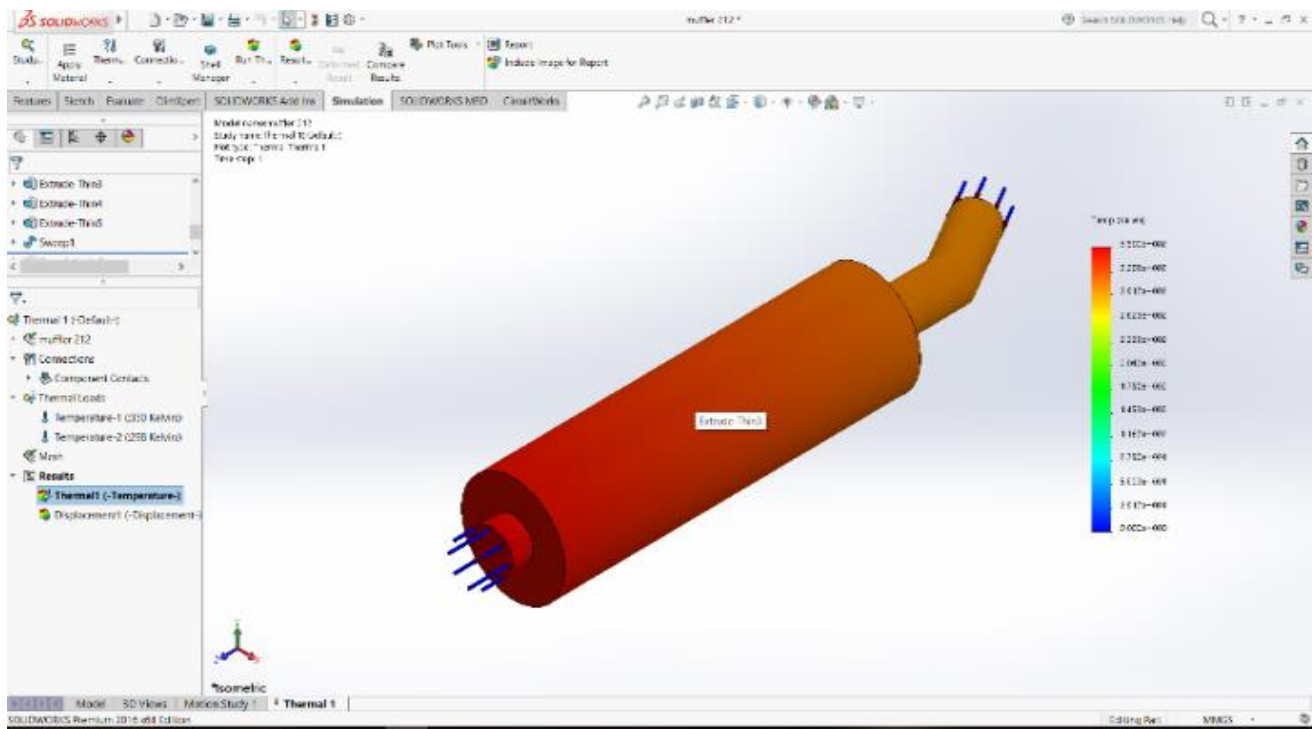

Fig 3: Figure thermal analysis of muffler

2) PRESSURE FLOW ANALYSIS: In the study the pressure flow analysis using the Finite volume method is carried out under which the muffler design is carried out for back pressure exerted by the muffler assembly.

Proposed design of the Muffler used in pressure analysis is shown in fig..C1 is the front expansion chamber with perforation at the piping and C2 is the extension provided for the noise and cancellation. For the research purpose the dimension is changed to reduce the back pressure exerted by the engine.

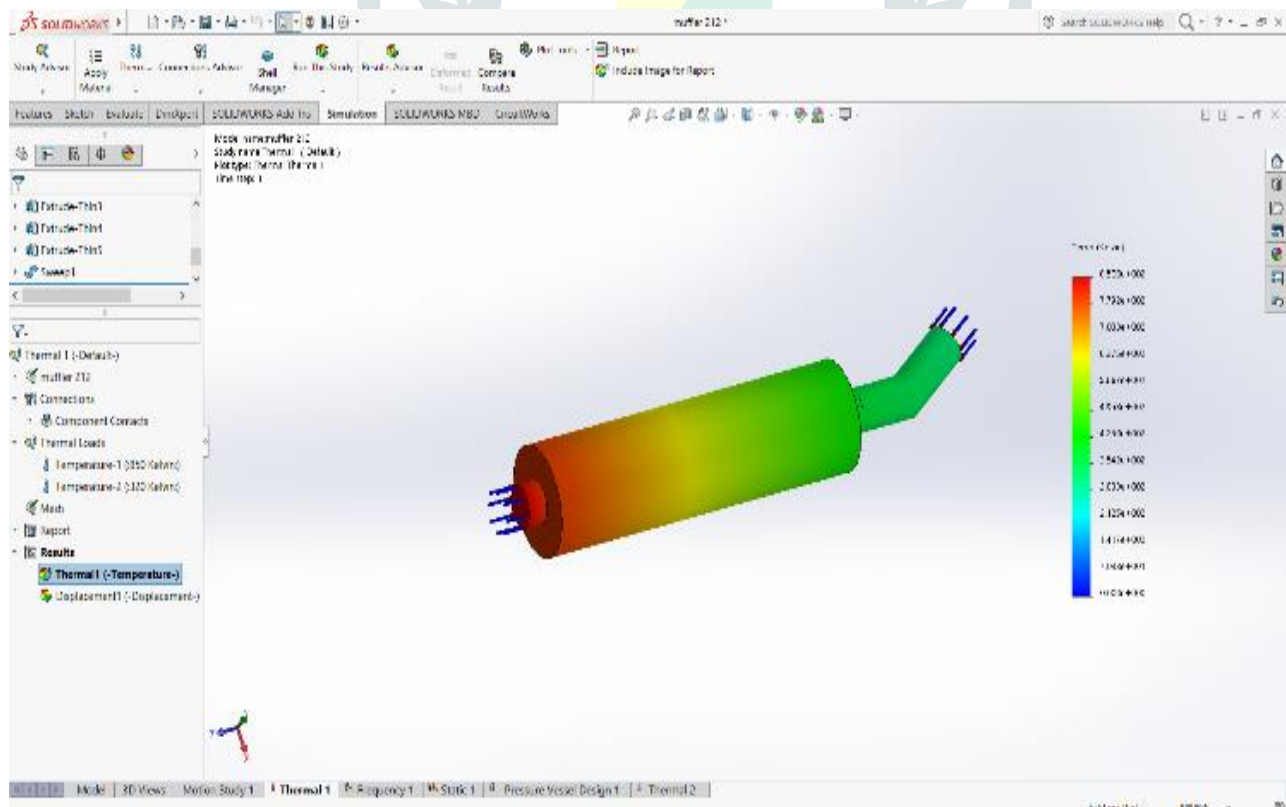

Fig 4: Figure Pressure analysis of muffler

3) vibration analysis: Vibration analysis of the muffler is carried out using the solid works flow simulation.in which the Vibration at the idling speed of 1400 to 1500 rpm is found in existing system are considered and accordingly the Resonance of vibration.

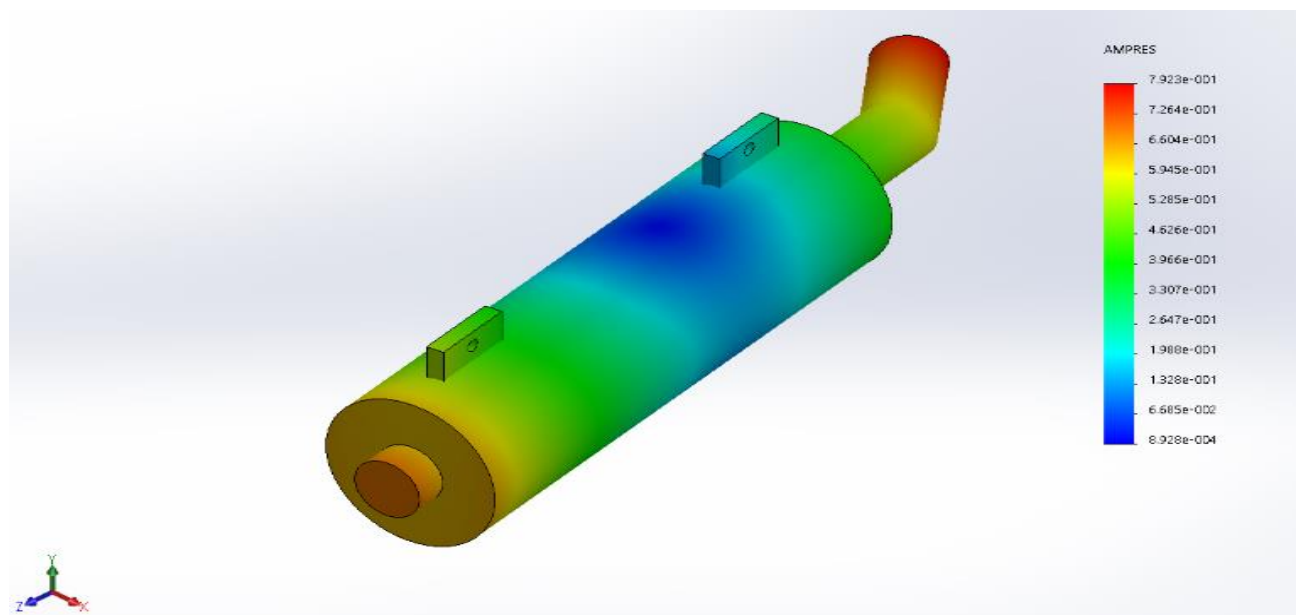

Fig 5: Figure Vibration analysis (1)

At the nodal frequencies' of 1500 Hz and rpm of 1400 – idling RPM of the vehicle vibration analysis is carried out using FFEplus solver for analysis from the analysis it is found that at the working condition of 1200 to 1400 rpm the brackets joints with the muffler body are more prominent to failure.

Another study is conducted under low frequency value of 500 Hz. In this study as seen in Fig. maximum and minimum working boundary condition was between 3.775e-001 to 3.771e-001 Ampres. Below are the measured frequency and Sum data of the study.

Mode Number	Frequency (Hertz)	X direction	Y direction	Z direction
1	0.072001	0.011948	0.016647	0.27469
2	0.09698	0.29479	0.37645	0.0013625
3	0.20555	5.9418e-005	5.361e-006	0.017324
4	0.25907	0.0023466	0.00067875	0.00065521
5	0.27278	0.0070663	0.0013945	0.00012688
		Sum X = 0.31621	Sum Y = 0.39518	Sum Z = 0.29416

Table frequency list 1

Mode Number	Frequency (Hertz)	X direction	Y direction	Z direction
1	0	0.99999	0	0
2	1200	0	0.99999	0
3	1200	0	0	0.99999

Mode Number	Frequency (Hertz)	X direction	Y direction	Z direction
4	1200	6.6696e-023	2.1633e-020	9.5762e-022
5	1629	2.0913e-020	2.0953e-026	2.6143e-023
		Sum X = 0.99999	Sum Y = 0.99999	Sum Z = 0.99999

Table frequency list 2

This frequency data is collected from the analysis carried out from two independent studies of frequency analysis. Below fig shows the variation in muffler from the study at 1400 working Hz and frequent damage to the bracket

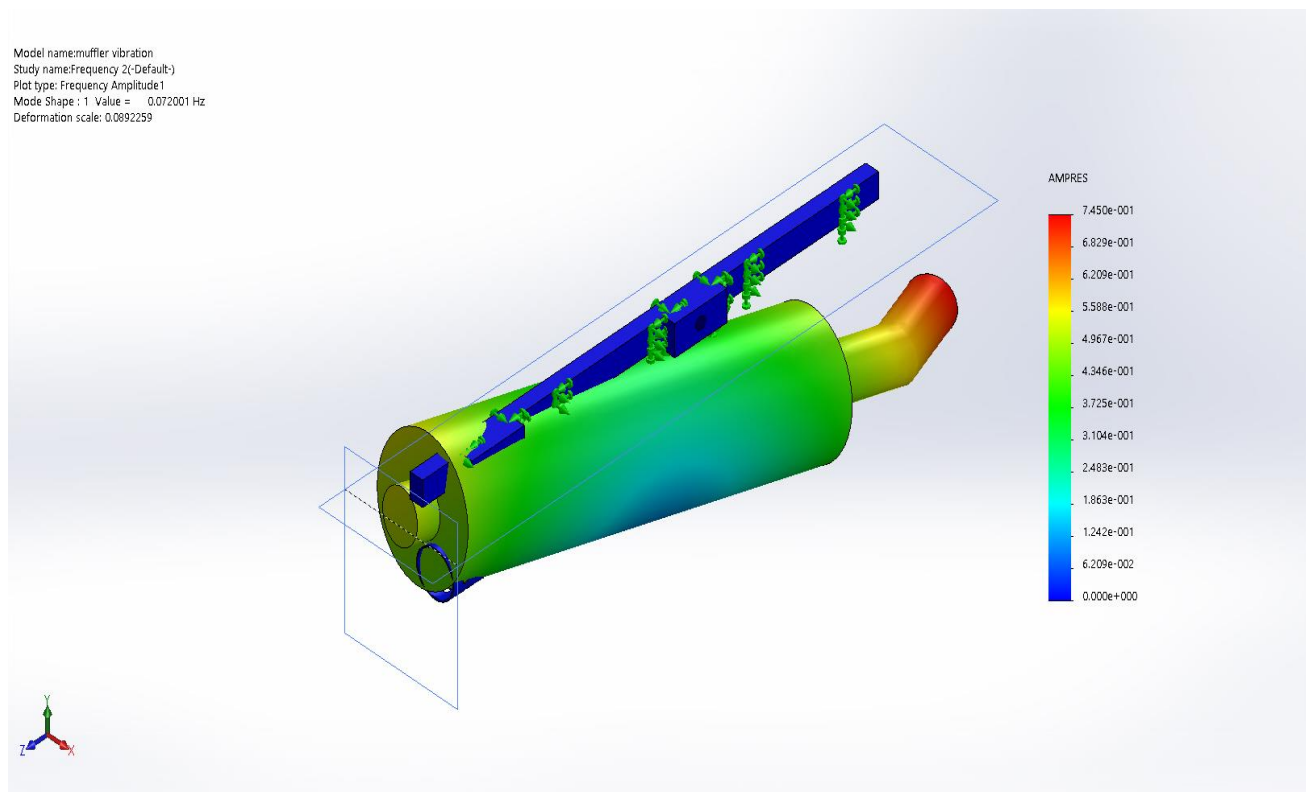

Fig. 6: Figure vibration analysis (2)

Mesh type	Solid Mesh
Mesher Used:	Standard mesh
Jacobian points	4 Points
Element Size	11.9805 mm
Tolerance	0.599027 mm
Mesh Quality	High

Table 5 mesh details

Total Nodes	41162
Total Elements	19619
Maximum Aspect Ratio	99.811
% of elements with Aspect Ratio < 3	22.9
% of elements with Aspect Ratio > 10	8.78
% of distorted elements (Jacobian)	0.01
Time to complete mesh (hh; mm; ss):	00:00:23

Table 6 Mesh information – Details

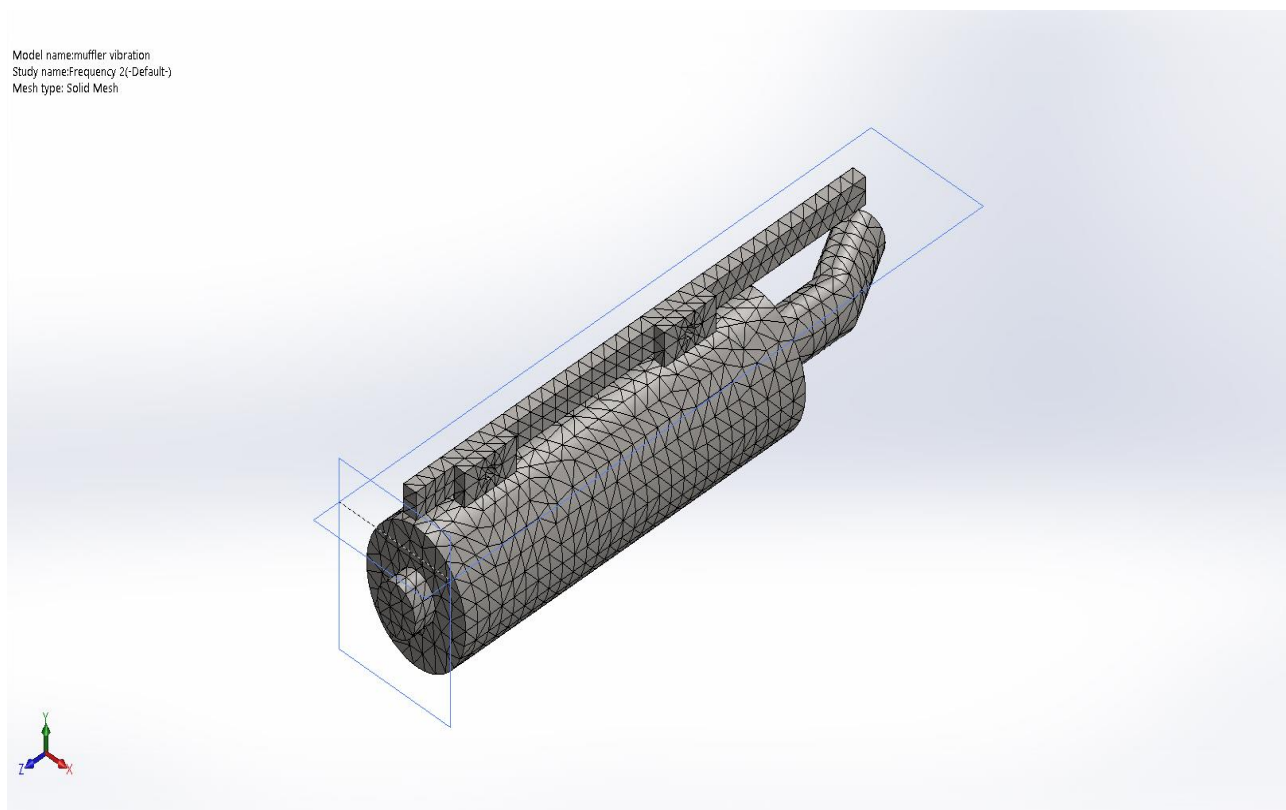

Fig. 7:Figure mesh design

FLANGE ANALYSIS

For the analysis of flange connecting exhaust pipe and catalytic converter static analysis is conducted using **solid works** modelling. Following are some analytical results and dimensions provided in the table below:

TABLE 5. 1 FLANGE DIMENSION

Name	Dimensions
Flange inlet diameter	21.4 mm
Flange outlet diameter	21.4 mm
Tightening bolt	M10x11
Inlet temperature at flange 1	850 K
Inlet temperature at flange 2	850 K

Torque for tightening	2.5 N.m
Reinforcing rib angle	5 degree
Reinforcing rib length	30 mm

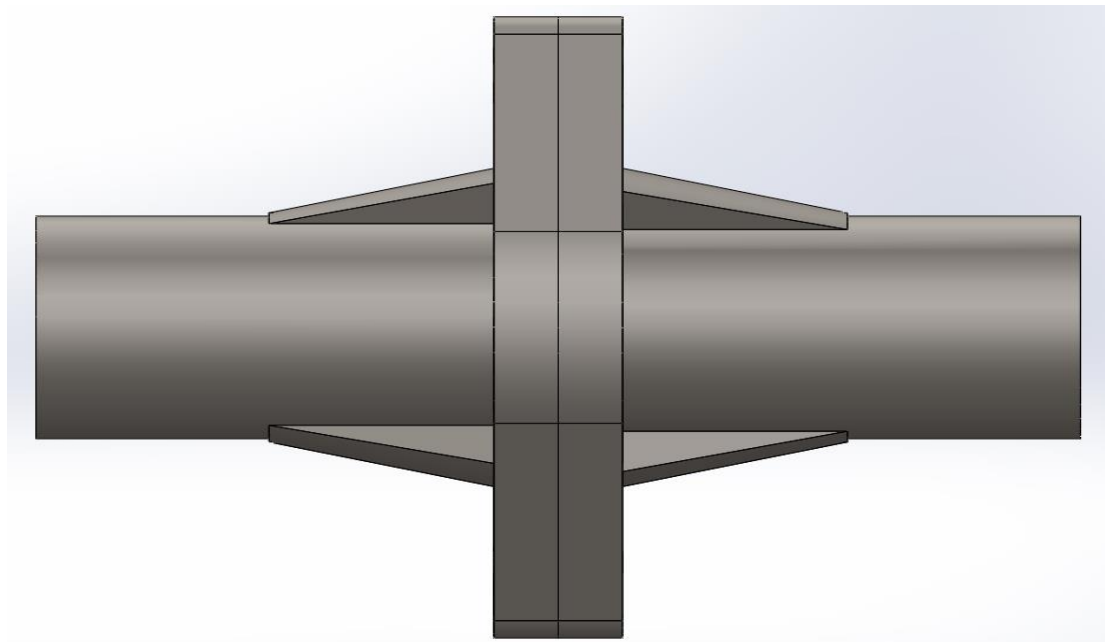

FIGURE 5. 1 FLANGE DESIGN

For the analysis of the flange design is prepared as stated above and static analysis is carried out with and without using Reinforcing material at the flange sides. From the analysis it is found that flange is more vulnerable to shear stress then using reinforcing material. Some of the analytic design are stated below:

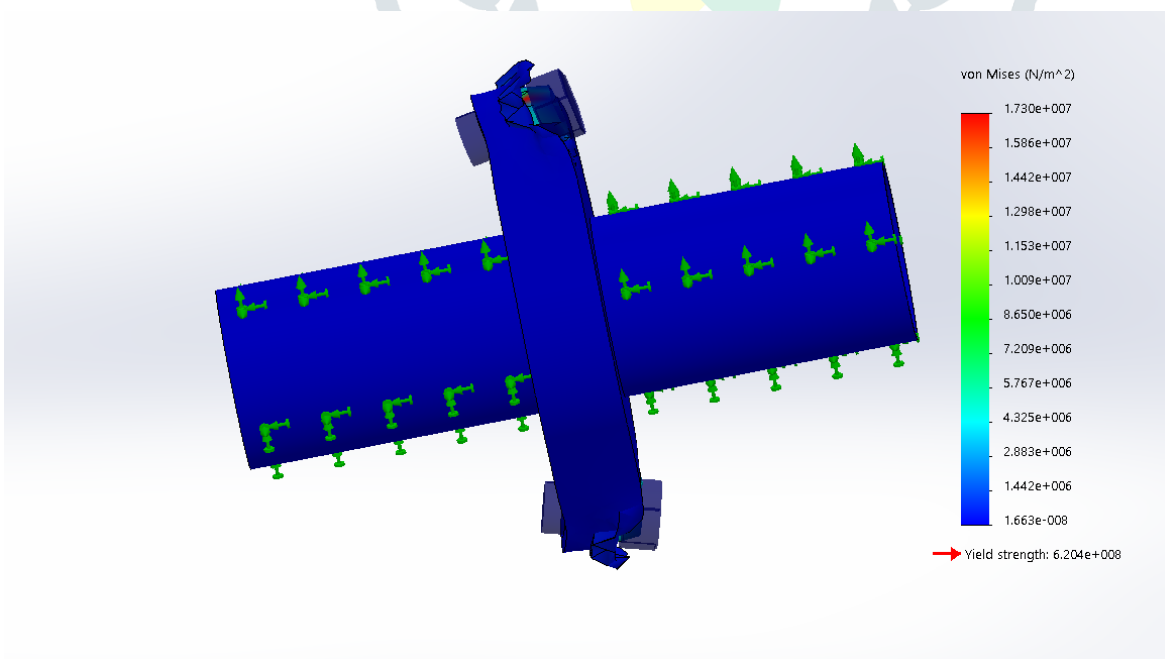

FIGURE 5. 2 FLANGE WITHOUT REINFORCEMENT

Without using the flange where the temperature goes to 850 k and tightening torque of 2.5 N.m portion of the flange is getting damaged from the mounting side of the flanges. This can be validated by static analysis carried out at 850 K temperature and atmospheric pressure condition.

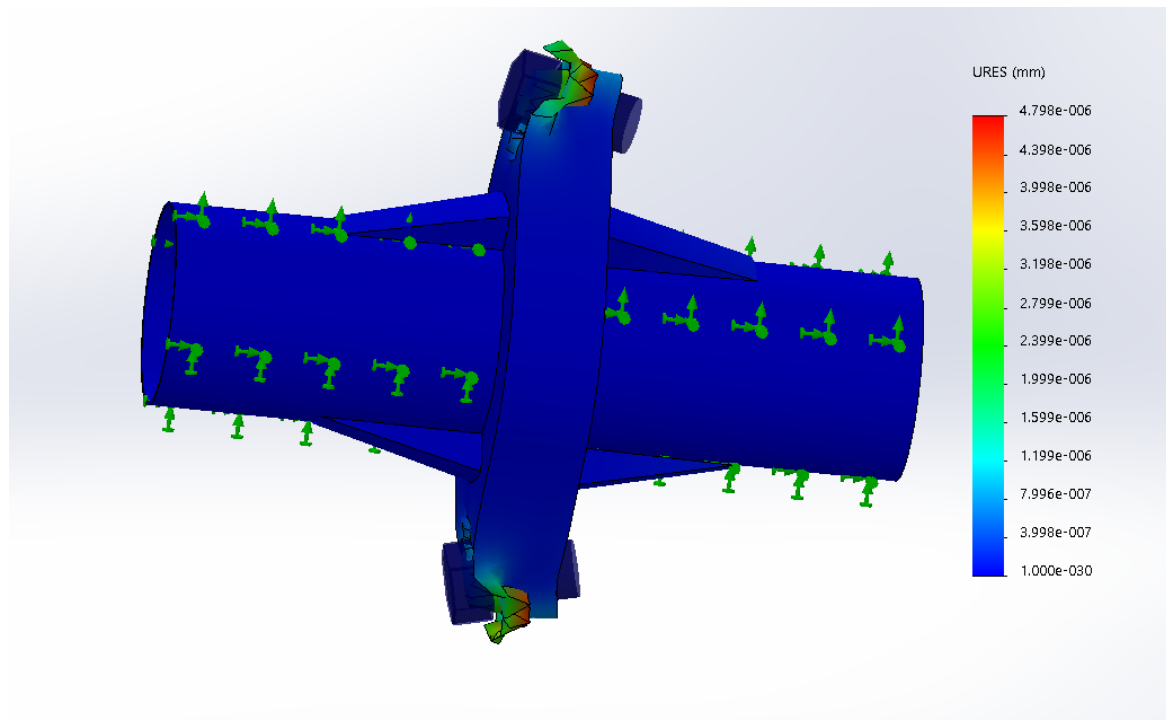

FIGURE 5. 3 FLANGE WITH REINFORCING MATERIAL

Where as compare to reinforcing material with inclination angle of 5 degree and 30 mm in length is provided in second study. This reinforcement has reduced the failure of Flange by the means of reduced stress concentration in the flange mounting bolts.

CORRECTIVE TESTING

From the analysis it is found that main reason of muffler failure is caused by the improper welding parameter used at the vender end. as seen in the diagram the thermal stresses generated at the weld portion is causing the damage to the muffler assembly.

Other modification also applied to the exhaust pipe mounting.in diesel engine the main failure problem is generated by the crake generation in muffler body and break of the exhaust pipe. exhaust pipe flange till now is mounted at an angle was carried out at 90 degree from the horizontal axis now the mounting angle of the flange is changed to 25 degree from the horizontal axis to reduce the vibration occurring from the engine generated by the flange mounting this modification is implemented by the R&D department and it is in trial phase. new mounting position of flange is as shown in figure.

For the analysis exhaust muffler is mashed in total 40748 nodes to analysis the vibration causing the failure of part from the analysis it is observed that at idealing rpm of 1400 rotation exhaust flanges are getting broken from the exhaust mounting side due to the high vibration.

1. Modification on Exhaust pipe mounting



Fig 8: Figure Exhaust mounting before

From the analysis it is observed that the exhaust pipe mounting can be modified to insulate the vibration of the exhaust mounting. For the insulation of vibration New clamp implemented for exhaust pipe mounting instead of mounting bracket .by implementing the new clamp with absorbing pad has reduced the vibration of exhaust mounting by 10 percent in vehicle.

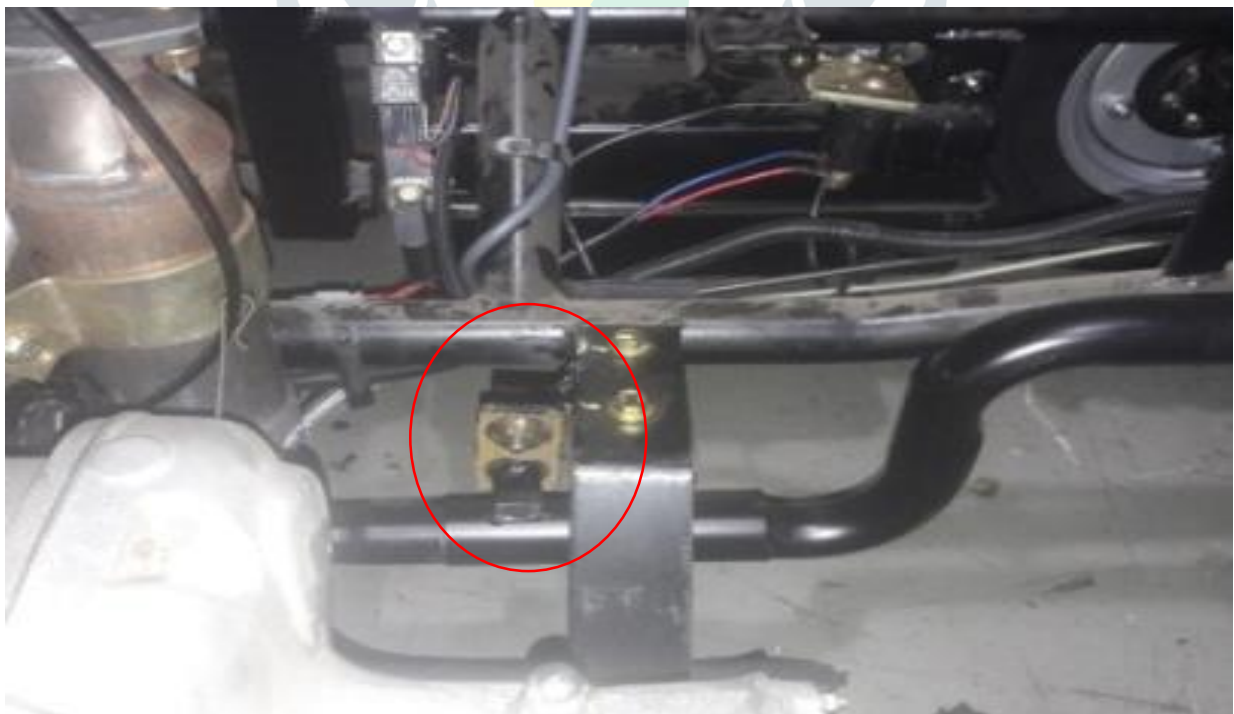

Fig 9.:Figure After modification mounting of the exhaust pipe

2. Catalytic converter mounting position

Till now the engine and catalytic converter are mounted to each by the steel plate with bolts. This mounting was transferring the engine vibration to the chassis and creating the vehicle vibration. To reduce the vehicle vibration mounting position of the catalytic converter changed as shown and, we have started using the OEM catalytic converter. Due to the change in design the life and durability of product is increased

Fig 10:Figure Catalytic converter mounting position before



First the main change in the muffler design is mounting position of the exhaust muffler. After the analysis it is found that the vibration can be isolated by increasing the thickness of the absorbing material and changing the mounting position of the brackets. Another change implemented is the mounting position of the bracket. In this the thickness of the absorbing material is increased by 2% that has led us to reduce in vibration by 5% in analysis.



Fig 11: Figure Catalytic converter mounting position After

3. Flange Design

Another main problem that is irritating the customers is the exhaust flange is getting broken during the working condition. This was creating the unnecessary noise and vibration from the vehicle to reduce that problem we have introduced the flange with the reinforcements. This reinforcement is providing the support to the flange in high loading condition.

To find out the problem is caused by the back pressure or not we have conducted back pressure analysis in plant and following results are found.[7]

Sample	Backpressure(kPa)	Limit(kPa)
1	32	50
2	43	50
3	52	50

Table 3. back pressure reading



Fig 12:Figure Exhaust flange mounting without reinforcement

To reduce the effect of vibration and prevent the mounting flange from getting separated one reinforcing element of 50 gm of molten metal is applied as the supporting member on both side of the pipe. This improvement has increased the failure report by 2% from the field. By providing the reinforcing material strength of the exhaust pipe against the stress concentration is reduce in favour to the failure of the muffler.



Fig 13: Figure Exhaust flange mounting with reinforcement

VII. CONCLUSION

- 1) By changing the mounting of the exhaust pipe assembly with rubber pad vibration is eliminated by 10%.
- 2) Flange with reinforcement can reduce the problem causing the separation of exhaust pipe and catalytic converter.
- 3) Vibration from the engine is grounded by removing the clamp from the catalytic converter and changing to OEM converter.

VIII. ACKNOWLEDGEMENT

Very thankful to Atul auto Ltd. For giving opportunity for completing Industrial Defined Project And faculties of Parul Institute of Engineering and Technology. I am very thankful to our senior engineer at company and internal and external faculties for the project guidelines.

REFERENCES

- [1] Ujjal Kalita, Abhijeet Pratap, Sushil Kumar, "Absorption Materials Used In Muffler," International Journal of Mechanical and Industrial Technology, Punjab, 2015.
- [2] S.H. Lee a,b, E.S. Kim a, J.Y. Park a, J. Choi, "Numerical analysis of thermal deformation and residual stress in automotive muffler by MIG welding," Journal of Computational Design and Engineering, Korea, 2018.
- [3] Shital Shah, Saisankaranarayana Kuppili, Kalyankumar Hatti, Dhananjay Thombare, "A Practical Approach towards Muffler Design, Development and Prototype Validation," SAE international, india, 2010.
- [4] Alfred, Samuel, "Researches on the Physics behind cooking as a pastime," 20 June 2017. [Online]. Available: <https://www.quora.com/What-are-the-dangers-of-continuing-to-drive-a-car-with-an-exhaust-pipe-that-is-rusted-through>. [Accessed 25 october 2018].

- [5] P. Srinivas, Venkata Ramesh Mamilla, G. Lakshmi Narayana Rao, Sowdager Moin Ahmed, "Design and Analysis of an Automobile Exhaust Muffler," Research gate, 2016.
- [6] Potente, Daniel, "General Design Principles for an Automotive Muffler," research gate, Australia, 205.
- [7] M. Philip Hubert Smith, "Exhaust and Intake Systems",3rd illustrated reprint," Foulic, 1976.
- [8] OVIDIU VASILE,GILBERT-RAINER GILLICH, "Finite Element Analysis of Acoustic Pressure Levels and Transmission loss With Muffler," researarch gate, romaina, 20132.
- [9] N.S.Ahirrao, Dr.S.P.Bhosle , Dr.D.V.Nehete, "Dynamics and Vibration Measurements in Engines," Science direct, India, 2018.
- [10] Murari Mohon Roy, Mohammad Uzzal Hossain Joardder and Md. Shazib Uddin, "Effect of Engine Backpressure on the Performance and Emissions of a CI Engine," JIMEC'7, bangladesh, 2010.
- [11] S.L.Shinde, Mr. Sanchit Babarao Dhotre1 Prof., "Analysis of Automotive Exhaust Muffler Silencer Using FEA and Experiment," IJFEAT, india, 2016.
- [12] Marsiaal, Milton O. Reeves, "Exhaust Muffler for Engines," Indiana, May 11 1897.
- [13] Jingxiang Li, ShengdunZhao, "Optimization of valve opening process for the suppression of impulse exhaust noise," ELSEVIER, china, 2014.
- [14] D.T. Oloruntoba, A.P.I. Popoola, "Effect of coating on induced thermal and tensile stress on fracture of exhaust pipe material," Elsevere, South Africa, 2014.
- [15] Dr. Ken Russel, "W a v e s Types of Waves Wave speed Longitudinal Waves," Isabelle Rickey, 2014. [Online]. Available: <https://slideplayer.com/slide/1607446/.html>. [Accessed october 2018].
- [16] Dr. Igor Anilovich, Michael Schellong,John W. Siekkinen, "exhaust system performance dignosis," IFAC, germany, 2010.
- [17] C., P. Om Ariara Guhan; G, Arthanareeswaran; K, N Varadarajan; S, Krishnan, "Exhaust System Muffler Volume Optimization of Light Commercial Vehicle Using CFD Analysis," elsevier, india, 2018.
- [18] Christopher George Therully,H G Vinod Raj, "Energy Efficient Design and Modification of an Automotive Exhaust Muffler for Optimum noise transmission loss and back pressure:A review," IOP Conference Series: Materials Science and Engineering, Karnataka, 2018.