

A Smart Switch to Connect And Disconnect Electrical Devices At Home By Using Internet

SURESH H BALLLA¹, J. VISHNU², G. CHANDRA SEKHAR³, DR. I. SATYANARAYANA⁴

¹ HOD, Dept of ECE, Sri Indu Institute of Engineering & Technology, Hyderabad, TS, India,
E-Mail: eechod.siiet@gmail.com

² PG Scholar, Dept of ECE, Sri Indu Institute of Engineering & Technology, Hyderabad, TS, India,
E-Mail: vardhanvishnu12@gmail.com

³ Asst Prof, Dept of ECE, Sri Indu Institute of Engineering & Technology, Hyderabad, TS, India,
E-Mail: gchandrasekhar5@gmail.com

⁴ Principal, Dept of ECE, Sri Indu Institute of Engineering & Technology, Hyderabad, TS, India,
E-Mail: principal.siiet@gmail.com.

Abstract: The proposed system can eliminate the disadvantage of the existing system in the proposed system we are using Wi-Fi instead of Zigbee and android mobile instead of Personal Computer Every user who is experienced in the existing system may think of a system that may add more flexibility and run with some common applications such as android. This work is designed in such a way to avoid the disadvantages of the existing system. The proposed system supports more elasticity, comfort capacity and safety. The main objectives is to design and to execute an cost effective and open source home automation system that's capable of leading most of the home and sustain the house automation system. The predictable system contains a great elasticity by using wireless reliable technology to interconnecting various modules to the server of home automation system. This paper presents the development of a firmware for a Smart Switch, which can control the on-off of any electrical device at home by using internet. The Smart Switch is connected to internet via Wi-Fi through a smart phone, tablet or any device with internet access. In order to perform this connection it is necessary to write the IP pre-programmed into the Smart Switch in a web browser with the purpose to load the Smart Switch server, which will open a configuration page to write the data of the user's network. Then, the user will select in automatic mode the network, the security type, and the user must have written a passphrase. Once these information is uploaded and saved, it is necessary to restart the Smart Switch in order to get access to internet, from which the user can control the Smart Switch simply sending a number one or a number zero to switch the electrical device, this process is done in principle via the internet.

Keywords— Home Automation, Internet Of Things, Smart Switch, Wi-Fi Technology.

I. INTRODUCTION

Today users of electricity to residential, have no way of knowing how much electric power consumed by each of their devices electrical connected to the network by the mere fact of being connected, even when not operating, making it difficult they can have control of energy consumption from their homes. Furthermore, most users spend too time away from home for its various activities, and nor has so connecting or disconnecting their devices electrical remotely during optimum periods of time, depending on the various

applications of each apparatus electric. There have been cases in which the user forgets network disconnect any electrical device high power consumption, which is undesirable and even dangerous; and only return home until it disconnects adverse consequences. Or it may be the case that the user you are not sure you have disconnected any appliance you should not stay connected, and usually must return home immediately with the respective loss weather. Based on these needs, work presents the developing a Smart Switch (SS), which is a device capable of connecting or disconnecting any device remotely Power that is connected to the outlet at home making use of internet. In this case, the SS acts as intermediary between electricity and the appliance. Furthermore, the proposed device can be controlled even without the use of internet, that is, if users do not have Internet can control the SS a locally within the building, using the local IP SS and using a computer, smart phone or tablet with access to the local network.

There are other devices on the market for home automation, such as starters automatic water pumps, air control conditioning, security systems, systems lighting, etc. However, most of these systems automation require complex devices are expensive, bulky and require facilities and operators specialized. However, with the proposed system you can control any appliance wiring by via a wireless device. By controlling wired devices using the wireless devices have achieved greater flexibility and extensibility, since its operation is easier, it can be applied to any electrical appliance at home and you will not need specialized staff for operation and installation. Currently, home automation is an area of opportunity that has attracted the attention of both the sector industry and the research. Lately, there has been He has been working in applications where various devices electrical communication with each other via the Internet are. Examples of network devices connected to the Internet are TV, alarm clock, refrigerators, radios, etc.



Figure 1. Devices home. a) Harnesses, b) Wireless.

Based on these needs, work presents the developing a Smart Switch (SS), which is a device capable of connecting or disconnecting any device remotely Power that is connected to the outlet at home making use of internet. In this case, the SS acts as intermediary between electricity and the appliance. Furthermore, the proposed device can be controlled even without the use of internet, that is, if users do not have Internet can control the SS a locally within the building, using the local IP SS and using a computer, smart phone or tablet with access to the local network. There are other devices on the market for home automation, such as starters automatic water pumps, air control conditioning, security systems, systems lighting, etc. However, most of these systems automation require complex devices are expensive, bulky and require facilities and operators specialized [1]. However, with the proposed system you can control any appliance wiring by via a wireless device, see Fig.1. By controlling wired devices using the wireless devices have achieved greater flexibility and extensibility, since its operation is easier, it can be applied to any electrical appliance at home and you will not need specialized staff for operation and installation.

II. TCP AND INTELLIGENT NETWORKS

A. Review of the TCP

The TCP protocol for its acronym in English "Transport Control Protocol "manages 95% of data traffic Internet and currently constitutes 80% of the total number of fluctuations in the Internet. The vast majority of fluctuations TCP are not very durable. The main distinction between the fluctuations

in short - lived and long - lived TCP (also Calls mice and elephants respectively) it is like window traffic grows. Short - lived fluctuations TCP They spend most of their lifetime in the phase slow start when the congestion window is increased exponentially. Fluctuations long - lived TCP also start in the startup phase, but they spend the most of his lifetime in the phase abate the congestion in which these perform congestion control multiplicative decrease of additive increase (AIMD) [4]. Although the Internet was originally designed for support its operation on various means of transport, Most of its components were optimized for networks wired. The TCP protocol, which provides most of Internet services (Web, FTP, Telnet) is one of those mechanisms that are, by design, inherently inefficient in wireless networks. This is the motivation behind continued research in this field. Different paradigms have been used to create solutions to the problem TCP wireless networks, but only few of them are currently possible to implement [5], [6], and [9].

TCP congestion algorithm has highlighted successful in achieving efficiency function Current internet. However, in recent years, it has been It is shown that it can perform very poorly in networks linked product bandwidth delay large (BDP). The problem is from the fact that the control algorithm standard TCP AIMD congestion the congestion window increases very slowly. This illustrated in Fig. 2. The graph which shows the evolution of the congestion window cwnd of a single stream, and compared with measured times on Jan. 1-Gb / s between Dublin, Ireland, and Chicago, IL. The propagation delay is 100 ms, and delay product bandwidth is approximately 8000 packets. [7], [9], [10]. One solution to this problem between Dublin, Ireland and Chicago, IL [7]. has been given by many authors is to increase the rate in which cwnd can be increased and therefore the congestion decreases [6], [7]. Many control schemes TCP friendly congestion have been proposed to follow the TCP equivalence criteria which state that a flow TCP equivalent should have the same performance with TCP if you experience identical network conditions as TCP.

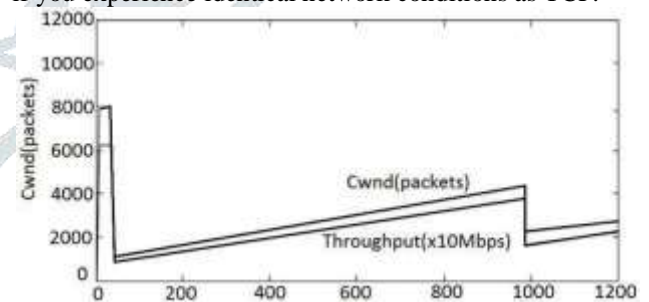

Figure 2. Measurement and cwnd times through records of 1-Gb / s

In addition, performance should converge as fast as TCP when conditions of data loss change. Media streaming such as video and audio conversations and movies online, often they are transmitted over the Internet. Because bandwidth available on the Internet is dynamic, a control mechanism Congestion is required to prevent the media flow suffer serious packet losses. A flow brought about TCP is generally subject to control mechanism congestion. TCP protocol transmission is mostly used in Internet and embeds control mechanism Multiplicative decrease congestion and increase

additive (AIMD) [8], [9], [10]. TCP provides important flow control characteristics, reliability, control congestion and connection management. Wireless media they are more exposed to transmission errors and undergo changes Topological. TCP-Vegas, TCP-Tahoe, TCP-Reno, TCP - New Reno, TCP SACK, TCP-Veno, TCPWestwood, TCP-Westwood-New Reno and TCPNew Jersey are some of the most important variations of TCP [9], [10].

B. Original Design of TCP

The TCP protocol is identified by a transport layer which provides a reliable and orderly data flow between two hosts. TCP in a highly sensitive defense protocol to the network congestion. To ensure communication reliable, TCP uses a packet acknowledgment (ACK) as a response to a package delivered successfully. The ACK are cumulative; each ACK brings the number sequence the next byte of data expected to be received. In case packet loss, the received packet following return the ACK packet received before the lost, making that the sender recognizes two identical ACK. To this was called duplicate ACK and are considered a sign lost packets [5]. TCP Westwood: TCP Westwood (TCPW) takes more aggressive estimate of band width available after a loss event occurred. Thus, Westwood emphasizes a dynamic algorithm that infers the network status from ACK received. This information It used an optimistic estimate of statistical width available bandwidth. Since the bandwidth changes each packet sent, Westwood makes estimates of bandwidth until receipt of each ACK [5], [9], [21]. TCP-Westwood NR: it based on TCP-New Reno. Improves network performance where lost packets due to wireless link errors and network congestion are more frequently by handling a wide delay product long band. Taking an average of the rates ACKs received the bandwidth is dynamically estimated available online [9].

TCP-Jersey: TCP-Jersey not only addresses the problem random congestion losses, also deals with loss Congestion more efficiently [5], [9].

TCP-New Jersey: It is proposed to distinguish data loss random congestion and reacting in consequence. The TCP sender estimates the wide sides available using the time between packet arrivals in the receiver. Use traffic information backed to handle back links [9].

TCP Veno: TCP Veno focuses on solving the problem uncongested random loss. It is very similar to TCP Vegas which it is an improvement of TCP Reno when entering an answer proactive behavior of the network[9].

TCP-Reno: A TCP implementation used by the most networks currently. Use different algorithms congestion control. They include mechanism prevent congestion, fast recovery, fast retransmit and slow boot [9].

TCP-New Reno: Reno is a variant of an improvement fast recovery algorithm (FR) in order to solve the problem of time outside where multiple packets were lost from the same window [9], [21].

TCP-Vegas: The estimation scheme bandwidth used by TCP Vegas it is more efficient than other variants TCP. This scheme estimating bandwidth using the difference

between the expected flow rate and the rate of Current [9] flow [21].

TCP-SACK: Selective Acknowledgement (SACK) as Reno is the problem of multiple lost packets. However, in TCP-SACK only provides recognition by selective segments which have been received successfully. TCPSACK therefore requires retransmission only one of these segments that have not been recognized [9].

TCP-Tahoe: Supplementing the TCP with different mechanisms slow start, congestion abatement quick recovery. However it differs from other variants TCP using a modified timing estimator round back [9].

TCP-STAR: It has been proposed to improve performance on satellite internet. TCP-STAR is the control method congestion consisting of three mechanisms; configuration the congestion window (CWS) based on the bandwidth available, internet due to bit error rate more significant and long propagation delay as explained in [11].

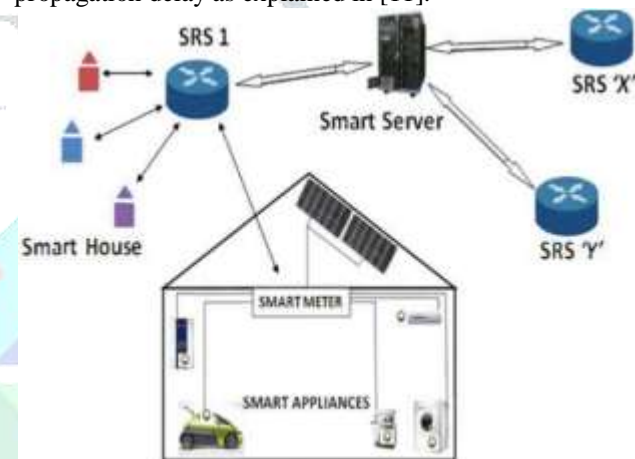

Figure 3. Topology of a network of distributed systems [13].

B. Smart Grid

From a global context, smart grid (or REI; smart grid in English) can be defined as the dynamic integration of developments in electrical engineering and advances in information technology and communication (or ICT) within the energy business electricity (generation, transmission, distribution and marketing tion, including alternative energy); allowing the areas of protection coordination, control, instrumentation mentation, measurement, quality and power management, etc., You are concatenated into a single management system with primary objective of making efficient and rational use of electric power. In this area, there is an emerging class of application in which there is a need to transmit data from a large number of measurement and control devices, a server core, [11], [14], and [22]. The previous concept also it could give the integration of other systems such as the protection. Thus, smart grids enter be part of a macro-concept of territorial domain, as it is the smart cities [14], [22].

III. DEVELOPMENT OF SMART SWITCH

A. The Smart Switch

A smart device is an electronic device, usually connected to other devices or networks through of different wireless protocols such as Bluetooth TM, NFC TM, Wi-Fi TM, 3G, etc., which can operate to some extent interactive and autonomous way (see Fig. 3). The opinion widespread is that these devices will surpass number to any other intelligent computing and communication in a very short time, in part, acting as a

useful tool for the Internet of things [23] facilitator. Among the various types of smart devices are the iPhone TM or most devices running Android TM operating system Apple TM, phablets and tablets (like the iPad TM Apple TM or Google TM Nexus TM 7) Smart- watches, smart and intelligent key chains bands (as Prestige Keys). The term can also refer to a Ubiquitous computing device: one that displays some properties of ubiquitous computing including but not necessarily artificial intelligence.

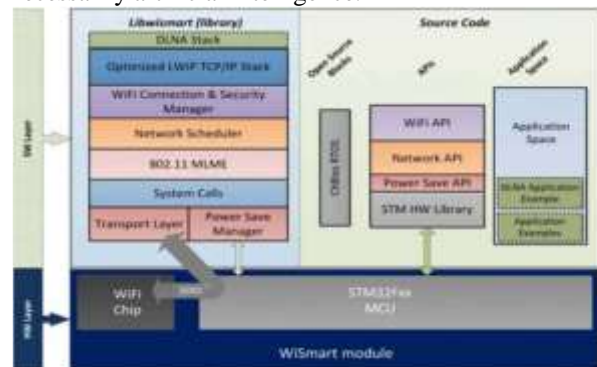

Figure 4. Solution Economies.

Intelligent devices can be designed to support a variety of form factors, a number of properties belonging to ubiquitous computing and is will use three main system environments: physical world, human centered environments and environments distributed computing. Different existing technologies were studied for such as home automation, Zwave, Enocean, Insteon Dealer and Zigbee, analysis of these was carried out technologies including Wi-Fi TM technology and chose use the latter for the development of this product. A Once this is understood proceeded to the acquisition of a module Wi-Fi TM which was the exit to internet, to monitor and SS control. He then proceeded to get a module assessment for the development of the application including Texas Instrument: different technologies such as studied ments, Lantronix, BLUEGIGA, Microchip, Econais and Murata Electronics, chose to purchase a module due Econais its low price because it has memory to perform application unlike the other in which they would have to use an extra chip for application development. HE conducted tests testing module Econais in FIG. 4 layers hardware and software shown device used. Later the program was carried out tion of the device settings to give access to internet via a computer, a smart phone or While a tablet or any other device with access to internet; providing only data network to which these other devices are connected (see Table I). A After completing the setup process proceeded to the programming device which involves the manipulation a switch to make way for electricity to any device that is connected to the SS. The commands AT they are proper for communication between devices Wi- Fi TM and modems, but these commands can vary according to the manufacturer Wi-Fi module TM. The way in which these

commands are sent to communicate with a modem is through a serial communication between the computer and the module Wi- Fi TM.

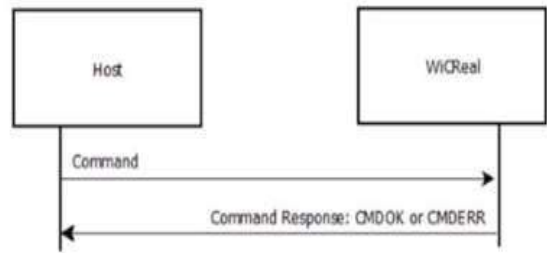

Figure 5. Command does not generate an event.

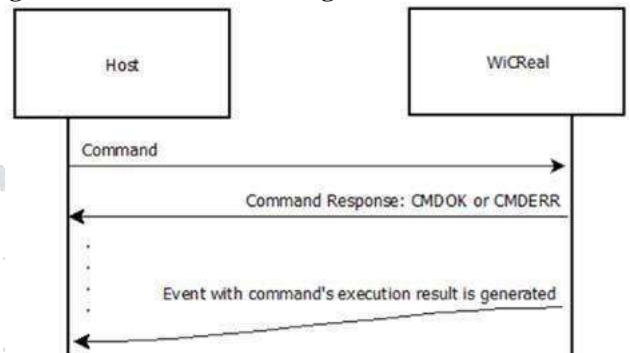

Figure 6. Command that generates an event back to the Host.



Figure 7. Red configured



Figure 8. User Registration.

B. Command, Answers & Events

The Wi-Fi TM module used for this work supports two types Command: which is the result of execution available immediately after the order of command. In this case, the user sends a command to the module execute and respond with a CMDOK if the command was or successfully executed a CMDERR if the command failed to be executed as shown in Fig5. TCP transmission example for the AT60 command is used and if the TCP transmission was successful, we return a CMDOK. On the contrary the module will respond with a CMDERR. Which commands the execution result will be available at some time in the future as shown in the Fig. 6. In this case the command is executed in two states. He First, examine whether the command has parameters correct. If this is correct, then the module will start execution of the command and respond with a CMDOK after the command completes its execution. Otherwise, will respond with a CMDERR. For example the command at17 (which initiates a scan). The module will start scanning and Will respond with a CMDOK the user. Scanning can take time to be complete and when this happens one CDMOK will be sent, the module will generate an event deb return the user to inform him in detail of the points access within the area Apply Changes



Figure 9. Apply changes.



Figure 10. Send data.

Scanning. It should be noted that both types of commands respond with CMDOK or CMDERR immediately, but some commands generate events future to update the user about events Asynchronous taking place. This enables both the user and the Wi-Fi TM module to enter a saving state power while the command is running. There are also two kinds of events that can be generated by the module: events that are generated as a result of receiving commands. Each time the module receives a command that generates an event; another event will be generated to inform the user about the command being executed. At17 always generate such an event back to user when scanning is complete. Events that are generated because some asynchronous events take place in module, so that the user is informed. These events they are not generated by the command execution. For example, the case where a TCP packet was received by the module. In this case the module will generate an event back to the user to inform the received packet. By default each event It is encapsulated in an ASCII string starting with "\R \nTXS \r \n" and ends with "\r \nTXS \r \n". The way events are sent is highly configurable, and the user you can completely redefine them to be formatted wanted. From the above application is developed for proceed to handle the proposed intelligent device this work. Once you configure your network you can display these data as shown in Fig. 7.

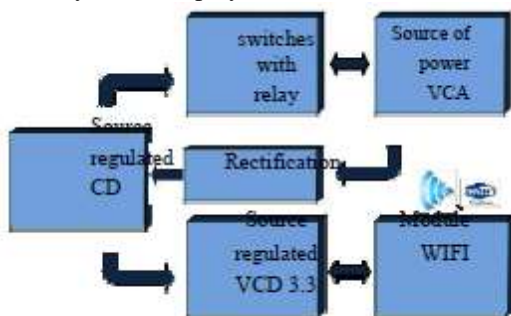

Figure 11. Block diagram of Smart Switch.

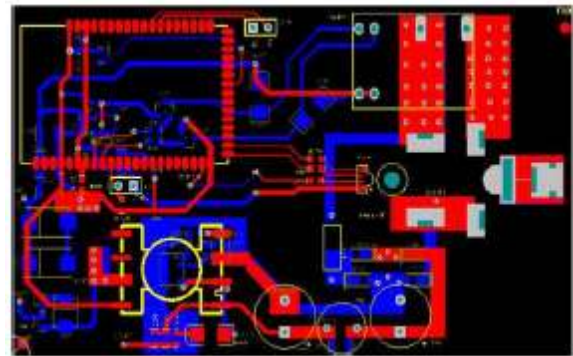

Figure 12. PCB Smart Switch.

IV. HARDWARE DEVELOPMENT

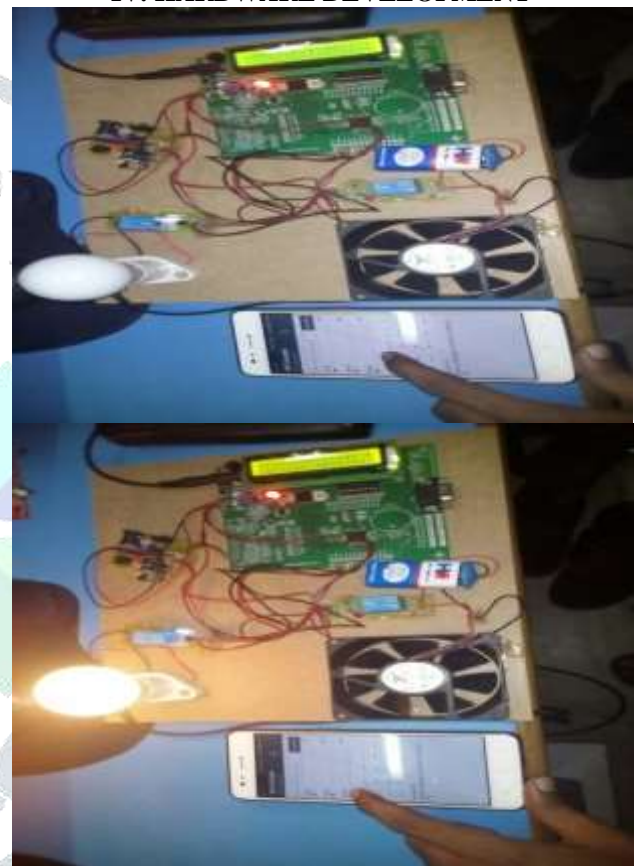

Figure13. Hardware Implementation.

VI. CONCLUSION

This paper presented the development of a contactor Smart (Smart Switch) controlled via the Internet, for on-off control or a remote way Local electrical household devices connected to the network. In order to fill a need for energy savings security and power users level residential. The experimental results confirm the theory, feasibility and reliability of the card developed, which she performed in a prototype stage and is currently being leading to a commercial stage.

VI. REFERENCES

[1] YT Park, P. Sthapit, and JY Pyun, "Smart digital door lock for the automation home ", in Proc. encon IEEE Conference, pp 1-6. 2009.
 [2] K. Atukorala, D. Wijekoon, M. Tharugasini, I.Perera, and C. Silva, "Smart eye - Integrated solution to home

automation, security and monitoring through mobile phones ". Third International Conference on Next Generation Mobile Applications, Services and Technologies. Sep. 15-18, pp. 64-69. 2009.

[3] M. Merabti, P.Fergus, O. Abualma'atti, H. Yu, and C. Judice, "Managing distributed networked appliances in home networks", in Proc., Of the IEEE, vol. 96, No. 1, pp. 166-185, 2008.

[4] S. Ebrahimi-Taghizadeh, A. Helmy, S. Gupta. "TCP vs. TCP: to systematic study of adverse impact of short-lived TCP flows on long- lived TCP Flows ". University of Southern California, Department of Electrical Engineering. Los Angeles, USA. 2005.

[5] M. Todorovic, and N. Lopez-Benitez. "Efficiency study of TCP Infrastructure protocols in wireless networks ". Texas Tech University, Department of Computer Science. 2006.

[6] A. Kuzmanovic, and EW Knightly, "TCP-LP: Low-Priority service via end-point congestion control."IEEE / ACM Transactions on Networking, Vol. 14, No. 4, 2006.

[7] Y.-T. Li, D. Leith, and RN Shorten. "Experimental evaluation of TCP protocols for highspeed networks."IEEE / ACM Transactions on Networking, vol. 15, no. 5, pp. 1109-1122. 2007.

[8] SC. Tsao, YC. Lai, YD. Lin. "Taxonomy and evaluation of TCP- friendly congestion-monitoring schemes on fairness, aggressiveness, and responsive ness."Network IEEE, vol 21. No. 5, pp. 6-15.2007.

[9] S. Henna. "A Throughput analysis of TCP variants in mobile wireless Networks ". Third International Conference on Next Generation Mobile Applications, Services and Technologies. Sep. 15-18., Pp. 279-284. 2009.

[10] X. Miao, Q. Feng, D. Ping, Q. Yajuan, Z. Sidong, ad Z. Hongke. "Fairness Evaluation of the Default High-Speed TCP in Common Operating Systems ". Proceedings of IC-BNMT2009., Pp.100-105. 2009

[11] H. Obata, S. Nishimoto, K. Ishida. "TCP Congestion Control method of improving friendliness over satellite internet." 7th International Conference on Information, Communications and Signal Processing, 2009. 2009. ICICS Dec. 8-10., Pp.1-4. 2009.

[12] T. Khalifa, K. Naik, M. Alsabaan, A. Nayak, and N. Goel. "Transport Protocol for Smart Grid Infrastructure "Second International Conference On Ubiquitous and Future Networks (ICUFN). June 16-18., Pp, 320-335. 2010.

[13] JJ Jamian, MW Mustafa, H. Mokhlis, MA Baharudin. "Conceptual Data Management and Communication System for Smart Distribution ". First IEEE Conference on Clean Energy and Technology CET. Jun. 27- 29, pp. 364-358. 2011.

[14] Madrid Save with energy. "Guide Smart energy networks and communication". 2011.

[15] X. Lu, Z. Lu, W. Wang, J. Ma. "On Network Performance Evaluation Toward the Smart Grid: A Case Study of DNP3 over TCP / IP ". IEEE Communication Society. Pp. 1-5. 2011.

[16] T. Isobe, Mr. Ito, Mr. Akashi, S. Tsutsumi. "RADIC-TCP: High-Speed Applied Protocol for Virtual Private WAN ". 18th International Conference on Tele communications. May. 8-11., Pp. 505-510. 2011.

[17] Y.-J. Kim, M. Thottan. "SGPT: Transport Protocol for Smart Grid Secure Reliable Delivery of Real Time Data Periodic ". Bell Labs Technical Journal. Vol. 16, no 3, Dec. 2011.

[18] JJ Jamian, MW Mustafa, H. Mokhlis, and MA Bahrain. "Smart Grid Communication Concept for Frequency Control in Distribution System ". The 5th International Power Engineering and Optimization (PEOCO2011). Jun. 6-7, pp. 238-242. 2011.

[19] T. Khalifa, A. Abdrabou, K. Naik, M. Alsabaan, A. Nayak, and N. Goel. "Design and Analysis of Split- and Aggregated-Transport Control Protocol (SA-TCP) for Smart Metering Infrastructure ". Third IEEE International Conference on Smart Grid Communications. 5 to 8 November. Pp139-144. 2012.

[20] M. Alowaidi, FR Yu, A. El Saddik, and, A. Aljanah. "Improving Performance of Smart Grid Communications using Multi-homing and Multistreaming Offered by SCTP ". IEEE Communication Networks for Smart Grids and Smart Metering. 2012.

[21] R. Pavani, and K, N. Sreenath. "Performance evaluation of TDP-Reno, TCP-New Reno and TCP West wood on Justification in an OBS Network ". 18th Annual International Conference on Advanced Computing and Communications (ADCOM). 2012.

[22] Z. Yue, Y. Ren, J. Li, and Q. Zhong. "The performance Evaluation and Comparison of TCPbased High-speed Transport Protocols ". Computer Network Information Center, Chinese Academy of Sciences. 2012.

[23] http://es.wikipedia.org/wiki/Dispositivo_inteligente

[24] <http://www.econais.com/>