

Hardware implementation of Automatic Power Factor Correction by using Capacitive Bank and Aurdino Micro controller

1.Mr. A. Raghavendra Prasad, Asst. Prof., Dep't of EEE, Santhiram Engineering College, Nandyal,
 2.Mr.M.Y.Veeresh,Asst.Prof. EEE Dep't,Santhiram Engineering College,Nandyal,
 3.Mr.N.V.S.Prasad,Asst.Prof. EEE Dep't ,Santhiram Engineering College,Nandyal.

ABSTRACT:

In the present imaginative surprise power is important. So we need to find the purposes behind control setback what's more, improve the impact system. As a result of industrialization the use of inductive burden additions and in this way

control structure adversities its efficiency. So we need to upgrade the force factor with a suitable strategy. At whatever point we are thinking about any programmable devices then the embedded development comes into fore front. The introduced is by and by a day particularly standard and most the thing are created with Microcontroller embedded innovation. Programmed control factor cure device scrutinizes control factor from line voltage and line current by choosing the deferral in the arrival of the current banner concerning voltage movement from the limit generator with high accuracy by using an internal clock. This time regards are then balanced as stage point and relating power factor. At that point the characteristics are appeared in the 2X16 LCD modules. By then the motherboard discovers the compensation essential and fittingly turns on different capacitor banks. This is delivered by using 8051 microcontroller. Programmed power factor adjustment procedures can be applied to the enterprises, power frameworks and furthermore house holds to make them steady and because of that the framework gets steady and productivity of the framework just as the mechanical assembly increments. The utilization of microcontroller diminishes the expenses

Keywords: APFC, Apparent power, Capacitor bank, Power factor and Microcontroller.

1.INTRODUCTION:

The low power factor prompts the expansion in the heap current, increment in power misfortune, and lessening in effectiveness of the generally speaking framework. In past different technique

use for power calculate remedy this strategy, the exchanging of the capacitor is manual. In this paper we are utilizing a strategy for the receptive force pay by capacitor exchanging with programmed control utilizing AVR microcontroller [1].

POWER FACTOR:

The power factor is the extent of dynamic capacity to the clear force .The dynamic force is the authentic force passed on to the stacks, for instance, motors, lights, etc. The responsive force is used distinctly to deliver appealing field for the surge of dynamic force. The clear force is the mix of the dynamic and responsive force. The stack current of any motor involve the resistive section and inductive portion. The inductive fragment involves of charging current and spillage current. The spillage current is completely dependent on the load current anyway the charging fragment is adjoining 20 to 60% of the full burden current. The capacitors are used to diminish inductive reactance in the enrollment motor right now incidents in the stock [2].

WELLSPRINGS OF REACTIVE POWER (INDUCTIVE LOADS) DECREASE THE POWER FACTOR [3]

- Transformers
- Induction Motors
- Induction generators (wind plant generators)
- High Intensity (HID) lighting

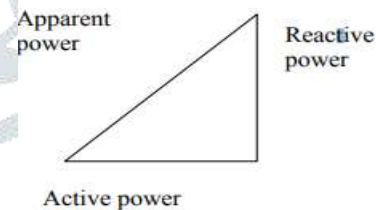

Fig- Power Triangle

ADVANTAGES OF POWER FACTOR CORRECTION

The focal points that can be accomplished by applying the force factor rectification are [4]:

1. Environmental advantage decrease of power utilization because of improved vitality proficiency. Diminished force utilization implies less ozone harming substance emanations and non-renewable energy source consumption by power stations.
- 2.Reduction of power bills.
- 3.Extra KVA accessible from the current stock. In transformers and dissemination gear (I*I)R misfortunes decline.

3. In long links decrease of voltage drop.
4. Extended gear life.
5. Reduced electrical weight on links and electrical Component.[5]

II. PROBLEM STATEMENT

An electrical burden that works on rotating flow requires evident force, which comprises of genuine power in addition to receptive force. Genuine force is the force really devoured by the heap. Responsive force is over and over required by the heap and offered back to the force source, and it is the recurrent impact that happens when substituting current goes through a heap that contains a responsive part. The genuine force is not exactly obvious force at whatever point responsive force is available which brings about a

power factor under 1 of electrical burdens. The responsive force builds the present streaming between the force source and the heap, which additionally expands the force misfortunes through transmission and appropriation lines. This brings about operational and budgetary misfortunes for influence organizations. In this manner, power organizations require their clients, particularly those with huge burdens, to keep up their capacity factors over a predetermined sum (typically 0.90 or higher) or be dependent upon extra charges. Electrical architects associated with the age, transmission, conveyance and utilization of electrical force have a significance in the force factor of burdens since power factors influence efficiencies and costs for both the electrical force industry and the shoppers. On the off chance that the working expenses are expanded, receptive force may require the utilization of switches, C.B, Transformers, transmission lines with higher current limits. In request to address the force factor of air conditioning burdens or transmission framework, there are different techniques accessible. One of the techniques is by exchanging the capacitors or inductor bets on or off which brings about dropping of inductive or capacitive impacts of the associated loads. At whatever point a non-direct burden is associated with a framework it makes symphonious flows notwithstanding the first Ac current. The above basic strategy depicted doesn't invalidate the receptive force at consonant frequencies, for this, there are different methods which must be utilized while managing the non-straight loads.[6]

III. BLOCK DIAGRAM

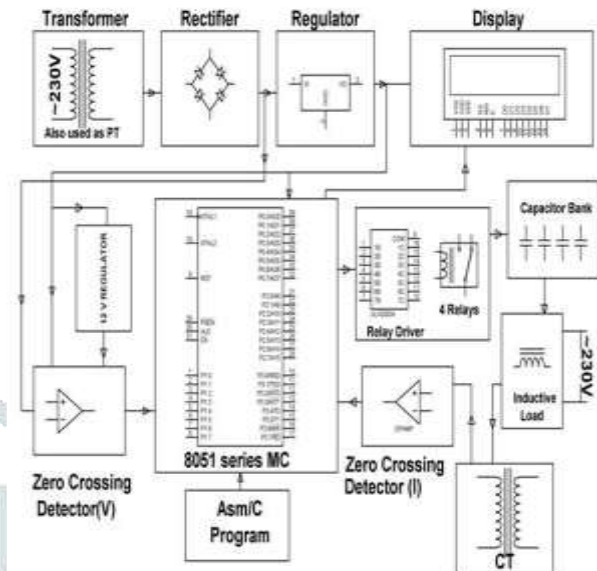

Fig. Block diagram of APFC unit

IV. METHODOLOGY

4.1 Power supply: In power supply we are utilizing step-down transformer. The 230 V air conditioning input supply is given to the essential of the transformer. Transformer is an electromechanical static gadget which changes power from one circuit to another without changing its recurrence. Because of the attractive impact of the curl the transition incited in the essential is moved to the auxiliary curl.[7]

4.2 Rectifier: The fundamental capacity of the rectifier is to change over the air conditioner voltage to the dc yield. The diode is a essential segment in the vast majority of the rectifier circuits since it leads a single way. This property of diode convert the sinusoidal voltages with zero normal incentive into waveforms that contains both air conditioning and dc segments (throbbing dc). It is a full wave connect rectifier.[8]

4.3 Voltage Regulator: The primary capacity of the voltage controller is to change over the variable yield DC voltage into the consistent DC voltage which is required for the inventory for the microcontroller and zero intersection identifier.[9]

Zero Crossing Detectors: The zero intersection identifier circuit is a significant use of the operation amp comparator circuit. It can likewise be called as sine to square wave convertor. It is utilized to recognize the sinusoidal wave zero intersection from

positive half cycle to negative half cycle. The reference voltage with which the info voltage is to be analyzed, must be made zero ($V_{ref}=0$). The information sine wave is given as a V_{in} . To quantify the time distinction between two waves we have to recognize zero intersection of two waves. Zero intersection identifier creates an yield state change at whatever point the info crosses the reference input.

4.4 Microcontroller: Microcontroller is an IC chip that executes programs for controlling different gadgets or machines. Its a smaller scale estimated IC chip gadget which is utilized for control of different gadgets and machines, that is the reason it is called microcontroller. It is a microchip having RAM, ROM and I/O ports. 8051 microcontroller is utilized in programmed power factor revision board. The microcontroller gets the heap current in the line and gives the sign to the transfer driver and at the same time associates the capacitors according to the need.[10]

Transfer: A hand-off is an electrically directed switch. Numerous transfers utilize an electromagnet to play out a exchanging component naturally, notwithstanding, extraordinary working standards are likewise used. Transfers are utilized any place it is basic to control a circuit by a feeble force signal or where various circuits must be constrained by unit signal. Current going through the curl of the hand-off produces an attractive field which pulls in a switch and switches the switch associations. The curl current can be on or off so transfers have two switch areas and most extreme have twofold toss switch.[11]

4.5 Relay Driver: Relay Driver is interfaced with the microcontroller yield. It is utilized to drives the different transfers according to the pay required.

4.6 LCD: LCD represents fluid precious stone presentation. It is a level board show or option electronic visual showcase that utilizes the light tweaking properties of fluid precious stones. fluid gem show is utilized to demonstrate the present force factor. 16x2 advanced presentation is associated with 8051 microcontrollers. it's reachable in an exceedingly 16 pin bundle with backdrop illumination, change of differentiation work and each speck grid have 5x8 dab goals.[12]

4.7 Capacitor Bank: Capacitors can be incorporated for pay of intensity factor through a transfer. A capacitor bank is a blend of various capacitors of the comparative rating that are associated in arrangement or corresponding with each other to stock electrical vitality. The subsequent bank is then

used to address a force factor slack or stage move in an air conditioner power capacitor does. They are proposed to store electrical vitality. The most fundamental utilization of a capacitor bank for Alternating Current force supply (AC) mistake improvement is in modern conditions, where an enormous number of transformers and electric engines are utilized. As this machine utilizes an inductive burden, they are receptive to stage moves and force consider slacks the force supply which may lessen framework productivity assuming left uncorrected. By incorporating a capacitor bank in the framework, the force slack can be adjusted at the least expense feasible for the organization when contrasted with rolling out remarkable improvements to the organization power lattice or framework that is providing the gear.

V.EQUIPMENT PREREQUISITES:

- 1.Capacitor Banks
- 2.Transformers
- 3.Diodes
- 4.PCB
- 5.8051 Micro Controller
- 6.LED
- 7.Voltage Regulator
- 8.Relays
- 9.LCD
- 10.Relay Driver IC
- 11.Switches
- 12.Resistors

Programming Requirements:

1.Embedded C language: Embedded C language is an extra to programming c language with some expansion of header records, from a controller to controller these header documents may vary. Embedded C programming depends on equipment engineering. It has cross advancement in nature. Embedded C writing computer programs is utilized for constrained assets like RAM, ROM and I/O peripherals on an inserted controller. Embedded C programming needs some non-standard expansions for the C language which is required to help a few highlights like fixed point number juggling, various very much characterized memory banks, and fundamental I/O operations. Programming of 8051 microcontrollers is first done in installed C and afterward changed over into Hex code and this code is dumped into microcontroller IC.

2.Compiler: A compiler is essentially an interpreter, a compiler is additionally a program which is worked to change the source code which is composed by an engineer in a double code which is otherwise called machine language. The procedure of changing over projects into machine language is known as gathering. A significant piece of the

interpretation process is that compiler sends admonitions or reports to its client about the blunders present in the source program. compilers are some of the time delegated single pass, multi-pass, load and go, troubleshooting, enhancing. There are two pieces of accumulation investigation and union. In the initial segment which is investigation it separates the program into its vital pieces and then again in the second part which is union, it constructs the ideal target program from the halfway portrayal. compilers make an interpretation of source code into object code and this is one of a kind for each sort of PC stages consequently there are numerous compilers accessible for a similar language.[13]

crossing detectors, Micro-controller, LCD display, Relays and Capacitor bank and Load circuit. Let us see how it operates. The required DC power supply for Micro-controller and other peripherals is supplied by the DC power supply.[14]

Steps of activity:-

- 1) Two signs (voltage and current) are introduced in Microcontroller from line by using C.T and P.T.
- 2) Microcontroller finds out stage point between this two banners by assessing time interval using clock.
- 3) Microcontroller discovers the force factor by equation (Cos X arrange edge) .
- 4) Then it discovers the necessary pay.
- 5) From given compensation it offers banner to Relay.
- 6) Then Contactors chip away at the transfer signal.
- 7) The necessary capacitors are incorporated structure.
- 8) As capacitors are incorporated, power factor gets extended.
- 9) Power factor is appeared in LCD.

VI.PROJECT DESCRIPTION

In this schematic diagram and interfacing of Arudino Uno microcontroller with each module is considered.

Fig Schematic Diagram of Automatic Power

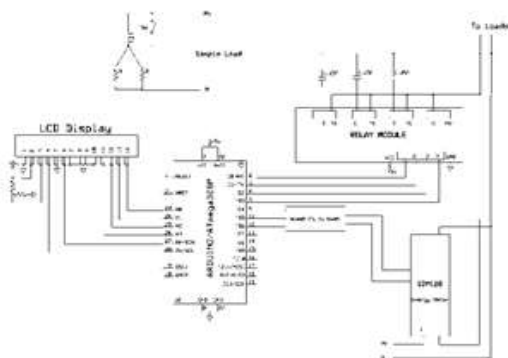

Factor Corrector using Capacitive Load Bank

The crystal oscillator connected to 13th and 14th pins of micro controller and regulated power supply is also connected to micro controller and LED's also connected to micro controller through resistors and motor driver connected to micro controller. This circuit consists of DC power supply unit, zero voltage

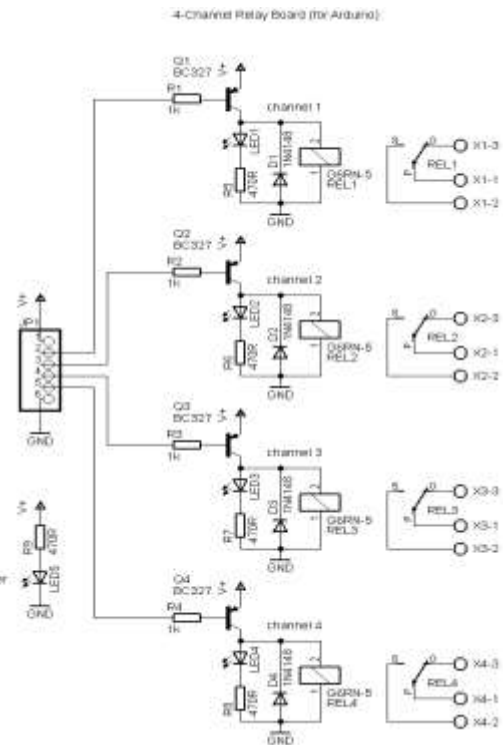

Fig .FOUR channel relay board

For the calculation of the power factor by the Micro-controller we need digitized voltage and current signals. The voltage signal from the mains is taken and it is converted into pulsating DC by bridge rectifier and is given to a comparator which generates the digital voltage signal. Similarly the current signal is converted into the voltage signal by taking the voltage drop of the load current across a resistor of 10 ohms. This A.C signal is again converted into the digital signal as done for the voltage signal. Then these digitized voltage and current signals are sent to the micro-controller. The micro-controller calculates the time difference between the zero crossing points of current and voltage, which is directly proportional to the power factor and it determines the range in which the power factor is. Micro-controller sends information regarding time difference between current and voltage and power factor to the LCD display to display them, Depending on the range it sends the signals to the relays through the relay driver. Then the required number of capacitors is connected in parallel to the load. By this the power factor will be improved.

FLOW CHART

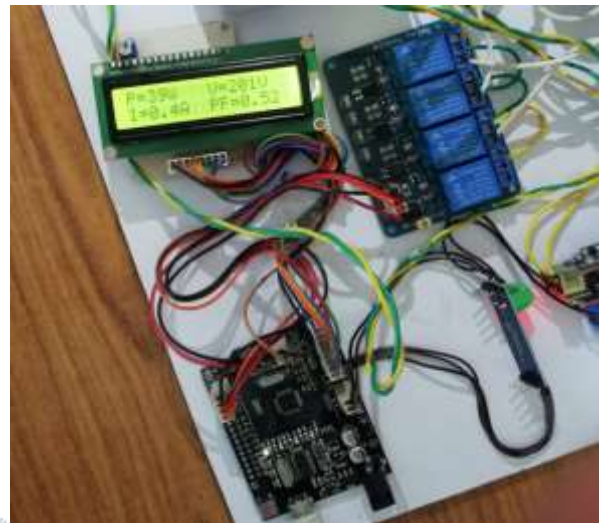
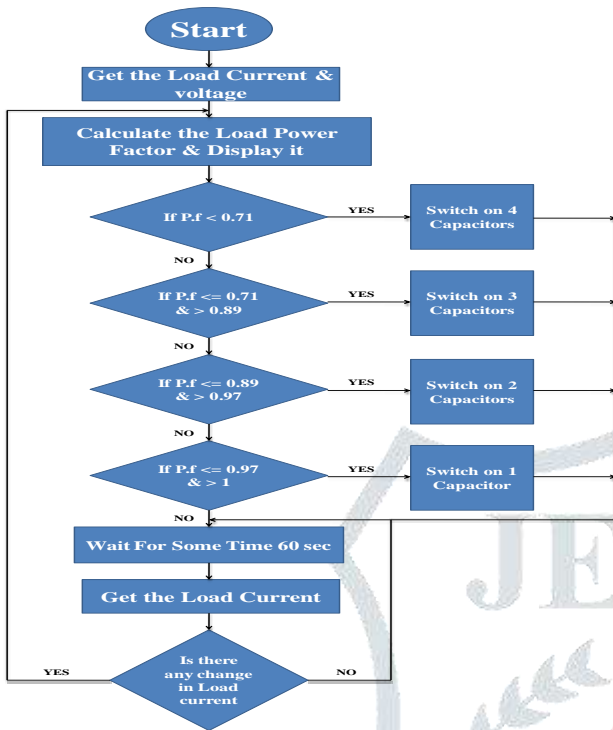

Fig.7.2 After adding the load

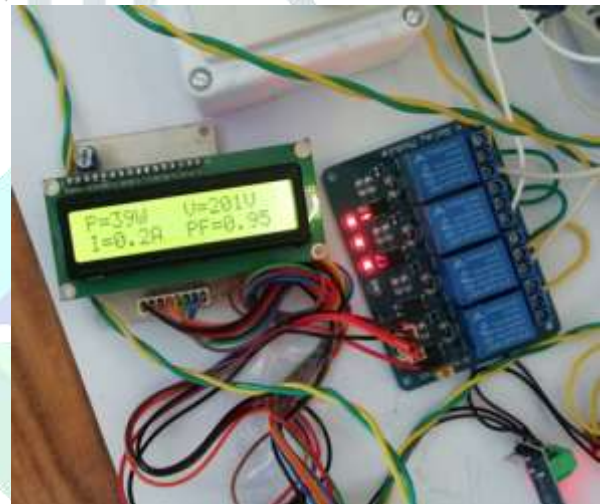

Fig.7.3 power factor nearer the unity

VII.RESULTS,CONCLUSION & FUTURE SCOPE

In this we are designed such that to provide continuous power factor correction without manual capacitive bank loading. A PFC controller provides power factor correction and peak current limiting for a switch-mode power converter of any topology (buck, boost or buck-boost), without having to directly sense inductor current.

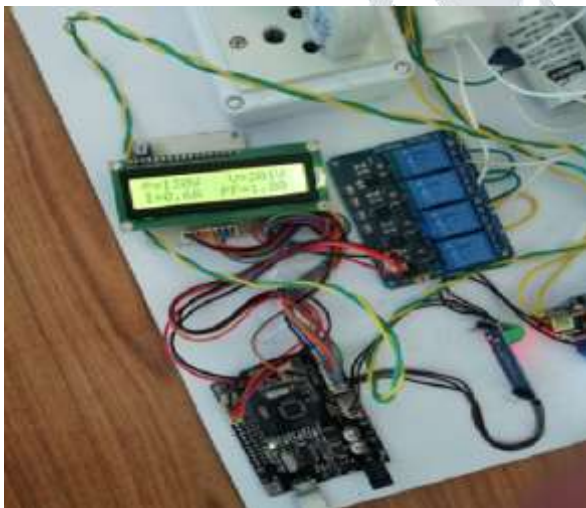

Fig.7.1 Before adding the load

CONCLUSION:

Integrating features of all the hardware components used have been developed in it. Presence of every module has been reasoned out and placed carefully, thus contributing to the best working of the unit. Secondly, using highly advanced IC's with the help of growing technology, the project has been successfully implemented. Thus the project has been successfully designed and tested. So, by using the Automatic Power Factor Improvement module we can efficiently improve the power factor for variable inductive loads, improving the life span of equipment and reducing power bills.

FUTURE SCOPE:

Our project is mainly intended to provide continuous power factor correction without manual capacitive bank loading. The Reactive Power charge on your electricity bill is directly targeted against those companies who do not demonstrate clear energy efficiency use. You will find this charge itemized on electricity bill. Reactive

power charges can be made significantly smaller by the introduction of Power Factor Correction Capacitors which is a widely recognized method of reducing an electrical load and minimizing wasted energy, improving the efficiency of a plant and reducing the electricity bill. It is not always necessary to reach a power factor of 1. A cost effective solution can be achieved by increasing your power factor to greater than 0.95 This project uses regulated 5V, 750mA power supply. 7805 three terminal voltage regulator is used for voltage regulation. Bridge type full wave rectifier is used to rectify the ac out put of secondary of 230/12V step down transformer. This project can be extended using Zigbee technology, which increases operating wireless distance. The system can also be extended using GSM technology which sends the alerting SMS messages about the power factor correction to the authorities.

REFERENCES

- [1] Sagar Jundare, Pranav Ukkadgaonkar, Minimizing Penalty in Industrial sector By Engaging Automatic power correction panel using microcontroller.
- [2] https://en.wikipedia.org/wiki/Power_factor
- [3] <http://www.electricaltechnology.org/2013/10/causesof-low-power-factor.html>
- [4] Power factor correction By John Ware
- [5] Muhammad Ali Mazidi and Janice Gillespie Mazidi, "Microcontroller and Embedded Systems".
- [6] IEEE transactions on industrial electronic vol no 3 february 1990 77A Microprocessor-Based Adaptive Power Factor Corrector for Nonlinear Loads H. M. Elbolok, M. E. Masoud, And M. M. Mahmoud.
- [7] P. N. Enjeti and R. Martinez "A high performance single phase rectifier with input power factor correction", IEEE Trans. Power Electron...vol.11, No.2, Mar.2003. pp 311-317.
- [8] "Electronic device and circuit" by Robert L. Boylestad, Louis Nashelsky
- [9] Power system" by j. b. gupta.
- [10] J.G. Cho, J.W. Won, H.S. Lee, "Reduced conduction loss zero-voltage-transition power factor correction converter with low cost," IEEE Trans Industrial Electron..vol.45, no 3, Jun. 2000, pp395-400.
- [11] Anant Kumar Tiwari, "Automatic Power Factor Correction Using Capacitive Bank", International Journal of Engineering Research and Applications, Volume 4, issued February 2014.
- [12] Keith Harker (1998). "Power System Commissioning and Maintenance practice." London: Institution of Electrical Engineers.
- [13] Mr. U.M. Sandeep kumar, S. Seetharamudu, "Load flow analysis by Newton Raphson method with and without UPFC" International research journal of Engineering and Technology (IRJET), volume 02, issue 09 Pg.no: 435-439, Dec-2015.
- [14] Mr. U.M. Sandeep kumar, M Siva Sankar, "Mitigation of Voltage sag, swell and Load harmonics by the combined operation of series APF and solar system", International Journal of Engineering Innovation & research, volume-6, issue-5, pg.no: 55-59 September-2017.