

MODELING, SIMULATION AND IMPLEMENTATION OF FIVE LEVEL CASCADED INVERTER SYSTEM

Neelashetty kashappa

Faculty, EEE department, Guru Nanak Dev Engineering College, Bidar
Karnataka-585401.

Abstract: This paper deals with modeling, simulation and implementation of five level cascaded inverter system. A five level inverter fed induction motor drive system is modeled and simulated using Matlab Simulink and the results are presented. The prototype of the system is also presented to compare the simulation results with experimental results. There is close agreement between simulation results and experimental results.

Keywords: Induction motor, Multi level inverter, Cascaded inverter, Total harmonic distortion, Matlab Simulink.

1. GENERAL

Multilevel inverter [MLI] topology is a most promising inverter topology for medium voltage and high power applications. This inverter synthesizes several different levels of DC voltages to produce a stepped AC output that approaches the pure sine waveform [9]. It has the advantages like high power quality waveform, lower voltage ratings devices, lower harmonic distortion, lower switching frequency losses, higher efficiency, reduced dv/dt stresses etc.

2. CASCADED MULTILEVEL INVERTER

Cascaded multilevel inverter is based on the series connection of inverter with separate DC sources. Cascaded multilevel inverters eliminates the excessively large number of bulky transformers required by conventional multilevel inverters, the clamping diodes required by diode clamped multilevel inverters and the bulky capacitors required by flying capacitor multilevel inverters. Therefore cascaded multilevel inverters (CMLI) appear to be superior to other multilevel structures. The cascaded multilevel structure uses two H-bridge

inverters: A main bridge and an auxiliary bridge. The load is connected in such a way that the sum of the outputs of these bridges will appear across it. The ratio of power supply between auxiliary bridge and main bridge of 1:1, 1:2 and 1:3 are used to produce, five level, seven level and nine level voltage across the output terminals.

3. OPERATION OF CASCADED FIVE LEVEL INVERTER

Five level inverter fed induction motor drive system uses a Symmetrical Cascaded Multilevel Inverter (SCMLI) consisting of two cascaded H-bridge inverters: a main bridge inverter and an auxiliary bridge inverter. The load is connected in such a way that the sum of the outputs of these inverter bridges will appear across the load. The ratio of power supplies between the auxiliary bridge and main bridge is 1:1.

The main bridge H_1 as well as auxiliary bridge H_2 consists of DC source of $1V_{dc}$ each as shown in Figure 5.2. By proper opening and closing of switches, each H-bridge can generate three different voltage outputs $+V_{dc}$, 0 and $-V_{dc}$. H_1 can generate these voltages by proper combination of four switches S_1 , S_2 , S_3 and S_4 . When S_1 and S_4 are simultaneously on, the output of H_1 is $+V_{dc}$, when S_2 and S_3 are simultaneously on, the output of H_1 is $-V_{dc}$. Similarly the output of H_2 can be made equal $+V_{dc}$, 0 and $-V_{dc}$ using S_5 , S_6 , S_7 and S_8 . Simultaneous turning of switches S_1 , S_2 or S_3 , S_4 or S_5 , S_6 or S_7 , S_8 results in zero output voltage. The output voltage of H_1 is taken as V_1 and the output voltage of H_2 is taken as V_2 . The output voltage of five level inverter is the sum of output voltages of 'H₁' and 'H₂' i.e. the output voltage $V = V_1 + V_2$. Thus the five level inverter output voltage of $+2V_{dc}$, $+1V_{dc}$,

0, $-V_{dc}$, $-2V_{dc}$ can be obtained. Table 5.1 shows the switching states of transistors, output voltage of H-bridges and output voltage of five level inverter. '0', status

means switch is in OFF state and '1', status means switch is in ON state.

Table 1: Switching states of transistors of five level inverter.

Voltage level	S ₁	S ₂	S ₃	S ₄	V ₁	S ₅	S ₆	S ₇	S ₈	V ₂	V = V ₁ +V ₂
1	0	1	1	0	$-1V_{dc}$	0	1	1	0	$-1V_{dc}$	$-2V_{dc}$
2	0	0	1	1	0	0	1	1	0	$-1V_{dc}$	$-1V_{dc}$
3	0	0	1	1	0	0	0	1	1	0	0
4	0	0	1	1	0	1	0	0	1	$+1V_{dc}$	$+1V_{dc}$
5	1	0	0	1	$+1V_{dc}$	1	0	0	1	$+1V_{dc}$	$+2V_{dc}$

4 SIMULATION RESULTS OF FIVE LEVEL INVERTER

The simulation is done using Matlab simulink version 7.9 and the results are presented.

The DC input voltage of each bridge of a cascaded structure is shown in Figure 1. The output voltage is shown in Figure 2. It can be seen that the output has 5 levels. The output current is shown in Figure 3. Three phase structure of five level inverter is

shown in Figure 4. The output voltage of the inverter is shown in Figure 5. Output current of the inverter is shown in Figure 6. The speed response of five level inverter fed induction motor drive is shown in Figure 7. The speed increases and settles at 1305 rpm. FFT analysis is done for the output current as well as output voltage and the corresponding spectrums are shown in Figure 8 and 9 respectively. The current THD is 7.09 percent and voltage THD is 8.40 percent.

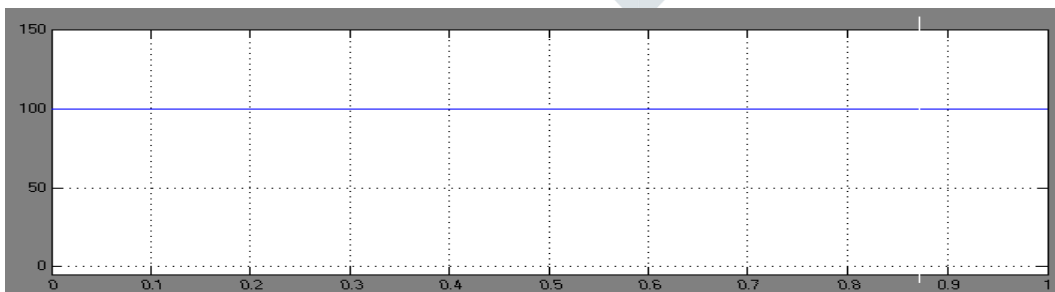

Figure 1. DC Input voltage of five level inverter with induction motor load

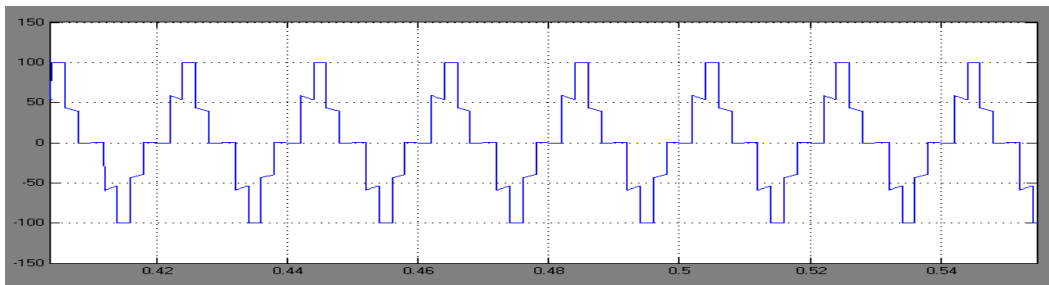

Figure 2. Output voltage of five level inverter with induction motor load

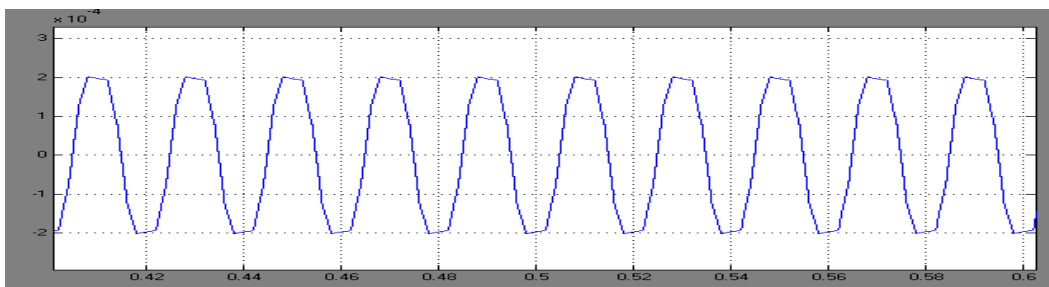

Figure 3. Output current of five level inverter with induction motor load.

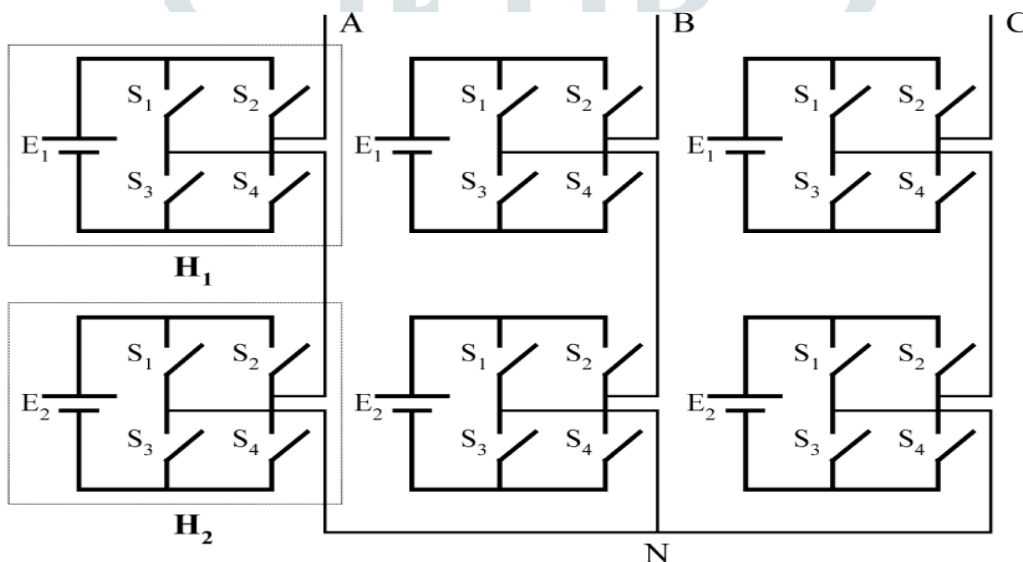

Figure 4. Three phase structure of cascaded five level inverter

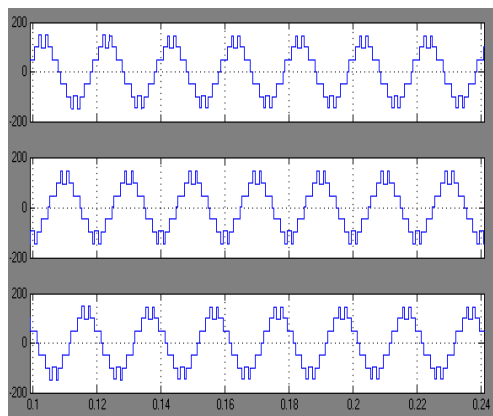

Figure 5. Output voltage waveforms of 3-phase five level inverter

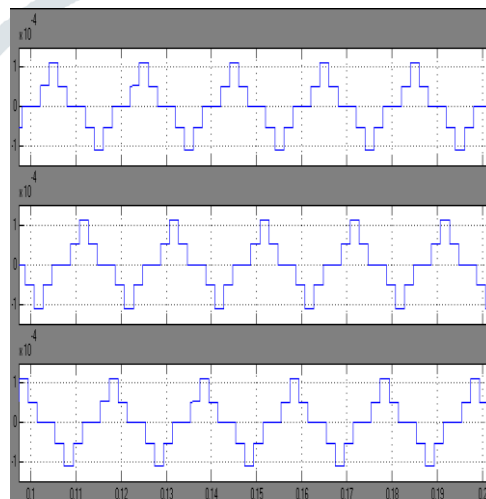

Figure 6 Output current waveforms of 3-phase five level inverter

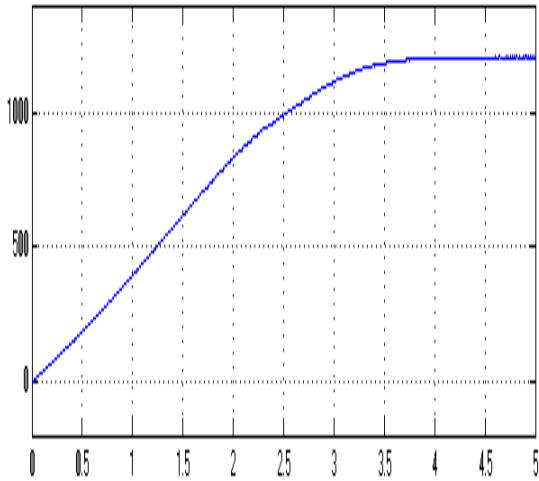

Figure 7. Rotor speed of five level inverter fed drive system

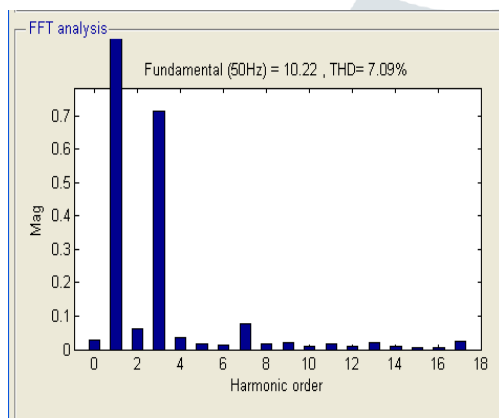

Figure 8. FFT spectrum for stator current of 3-phase 5-level inverter

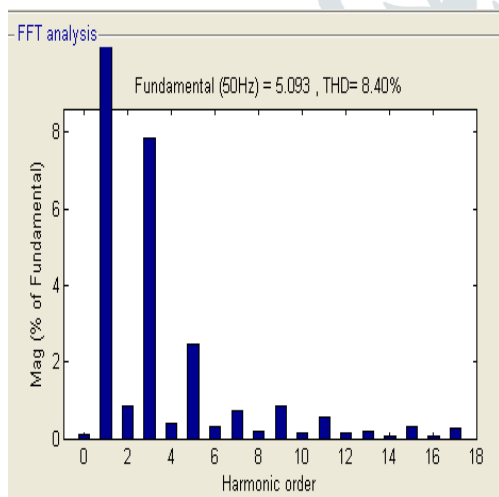

Figure 9. FFT spectrum for stator voltage of 3-phase 5-level inverter

5. HARDWARE RESULTS

Laboratory module for the hardware of five level inverter is fabricated, tested and the corresponding results are presented here. The hardware consists of micro controller module, pulse amplifier module and IGBT module. The switching pulses for MOSFETs M_1 and M_5 are shown in Figure 10. Output voltage of five level inverter fed induction motor drive is shown in Figure 11. The experimental value of current THD of five level inverter is 6.64 percent and voltage THD is 7.81percent.

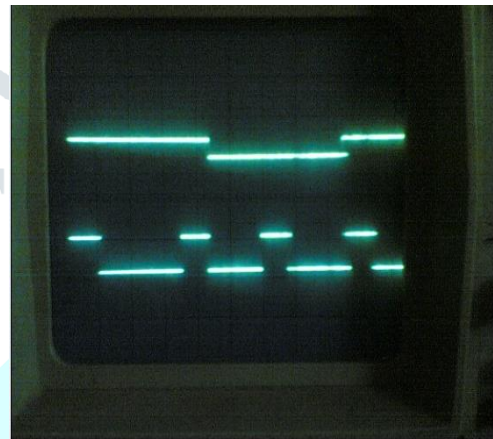

Figure 10. Switching pulses for M_1 & M_5 of five level inverter

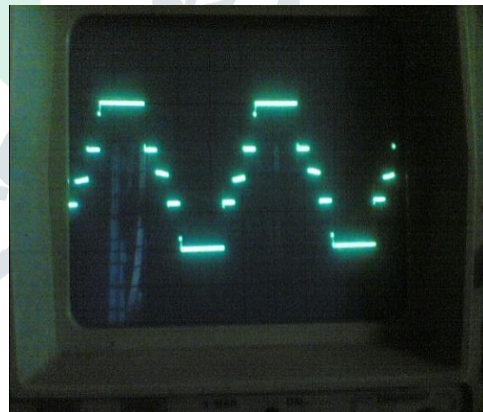

Figure 11. Output voltage of five level inverter

6 CONCLUSION

Five level cascaded inverter fed induction motor drive system with equal DC sources is modeled, simulated and implemented successfully. Simulation and experimental results for stator voltage, stator current, rotor speed and FFT spectrums of five level inverter system are presented. The hardware results of three phase five level inverter system are also presented. The experimental value of current THD is 6.64 percent. There is close agreement between simulation and experimental results. The efficiency of five level inverter fed induction motor drive system is 74.43 percent. The THD values of five level inverter system are less than that of three level inverter system and the efficiency as well as rotor speed of 5 level inverter fed induction motor drive system are more than that of 3 level inverter system. Therefore five level inverter is better than three level inverter system.

REFERENCES

1. Zhong DuLeon, M. Tolbert, and John N. Chiasson, "Active harmonic elimination for multilevel converters", IEEE Transactions on Power Electronics", 21 (2), 2006, pp 459-469.
2. G. Pandian and Ramesh Reddy, "Implementation of multilevel inverter-fed induction motor drive", Journal of Industrial Technology. 24(2), 2008, pp. 79-85.
3. Chunmei Feng, Jun Liang and Vassilios G. Agelidis, "Modified phase-shifted PWM control for flying capacitor multilevel converters", IEEE transactions on Power Electronics, Vol 22, No 1, 2007, pp. 178-185.
4. Shivakumar E.G, Gopukumar K, Sinha S.K and Ranganathan V.T, "Space vector PWM control of dual inverter fed open-end winding induction motor drive", IEEE APEC Conf. 1, 2001, pp. 399-405.
5. Bhagwat P. M. and Stefanovic V. R, "Generalized structure of a multilevel PWM inverter", IEEE transactions on Industrial Electronics, Vol 19, No 6, 1983, pp. 1057-1069.
6. Nam S. Choi, Jung G. Cho and Gyu, "A general circuit topology of multilevel inverter", Proceedings of 22nd Annual IEEE Power Electronics Specialists Conference, 0-7803-0090-4/91/0777-0096, 1991, pp. 96-103.
7. Nabae H, Akagi and Takahashi I, "A New Neutral Point Clamped Inverter", IEEE Transactions on Industrial Electronics, Vol. IA-17, No 5, 1981, pp. 518-523.
8. Cassiano Rech, Humberto Pinheiro, Hilton A Grundinh, Helio L, Hey and Jose R. Pinheiro, "Analysis and comparison of hybrid multilevel voltage source inverters", Proceedings on Power Electronics Specialists Conference 2002, PESC Vol 2, 2002, pp. 491-496.
9. June-Sung Kim, Tae-Jin Kim, Dae-wook Kang and Dong-Seok Hyun, "A novel method of the harmonic analysis by the multi-carrier PWM techniques in the multilevel inverter", 0-7803-7474-6/02, 2002.
10. Madhukar Waware and Pramod Agarwal, "Use of multilevel inverter for elimination of harmonic in high voltage systems", Proceedings of 2nd International Conference on Computer and Automation Engineering (ICCAE), Singapore, Vol 2, 978-1-4244-5586-7/10, 2010 IEEE, pp. 311-315.