

# A REVIEW ON IMPACT OF MULTI BUSBAR TECHNOLOGY IN MODULE MANUFACTURING

Gaurav Tiwari\* , Dr Ruchi Pandey\*\*

\*M.Tech Scholar, GGITS Jabalpur, \*\*Head EX Department, GGITS Jabalpur

**Abstract-** World in this century had seen extensive dependence of human civilization on energy sources. Earlier dependence on coal fired power plant and petroleum products have caused problem such as climate change and global warming. Solar energy is the next viable option which causes least negative impact on our environment. Current demand in industry is to increase the efficiency of the installed solar module by optimizing the cost and efficiency. Busbars are the metallic strips printed on the front side of solar cell, the generated current due to photoelectric effect is carried by these busbars. Silver being the best conductive material, busbars are made of silver paste. Computational studies have shown that increasing the busbar increases the efficiency at cell level and also decreases the amount of silver required to carry current along the busbar. Current work focuses on effect of increasing the no of busbar on the efficiency and also the silver paste consumption. This work shows the increase in efficiency is around 5% for 5 BB and around 10% for the 6 BB from current industrial module working with 4 BB and silver paste consumption is reduced by 42% and 58% for 5 BB and 6 BB respectively. This works shows that multi busbar technology could be used to improve efficiency and simultaneously reduces the input cost.

**Index Terms-** Busbar, Solar module efficiency, fill factor

## I. INTRODUCTION

Sun is the ultimate source of clean and green energy, this is because of nuclear reactions taking place, and basically the hydrogen atom undergoes nuclear fusion reaction which results in release of enormous amount of energy. This enormous amount of energy in form of heat and light propagate in all direction at speed of light. The energy which propagates from sun is converted into different forms, as we know that energy cannot be created or destroyed but it can get transformed, like green plants convert light energy of sun through the process of photosynthesis into food (chemical energy). We humans and animals eat plants to survive and get energy for all our activities.

Wind energy is created by the spatial difference in amount of heat received from the sun which creates pressure difference causing wind to move with high speed and this kinetic energy can be utilized by the wind turbine to transform it into electrical energy. Flow of water by virtue of topographical gradient is transformed to electrical energy using turbine. Fossil fuels such as coal, oil natural gas are generated over a very long period of time beneath the surface of earth due to extreme pressure and temperature. The living matter like plant and animal i.e. organic matter get decomposed and fossilized in extreme conditions. These living matters get their energy from sun through photosynthesis the amount of Sun's energy which we get on earth surface in 1 hour is much more than the energy requirement of whole planet for one year. We get enormous amount of heat and light energy from Sun both these forms of energy can be utilized to meet our ever increasing demand of energy and power. Heat energy of sun can be used in different ways such as heat energy of sun can be directly used to heat water or cook food, like heat collector: evacuated heat collectors, flat plate collectors and parabolic collector. Light energy of sun can be converted into electrical energy by using photo-voltaic cells there is a deep ongoing research in improving the efficiency of PV cells and decreasing its cost. In a time span of over 10 years the efficiency of these PV cells have improved from 9 % to maximum 24%. Sun's energy is evenly distributed over the Earth surface, maximum land area receives good amount of solar insolation. Due to all the advantages of solar energy, India has rapidly implemented solar power and achieved the first target of 20 GW, in 2017, and set up the new target of 100 GW by the year 2022. Around 4 to 5 acre of land is required to setup a solar power plant of 1 megawatt capacity; it will generate 4500 units daily. Rooftop solar power plants have played an important role in achieving the targets of government policies.

Research and studies are going on to increase the efficiency of solar cell and solar module. By improving the efficiency of solar modules, there is reduction in the area required to setup a solar plant. Also the reduction in cost of solar module per watt, decrease the LCOE levelized cost of electricity. The lowest quoted tariff of solar energy is 2.45/kWh, means Rs 2.45 per unit.

My area of work will be focused on improving the efficiency of solar modules by adopting the advanced solar module manufacturing technology.

**Climate Change:** With time the increasing human dependence on energy has lead to release of waste into the environment. Now with improper management of these wastes the earth is experiencing an enormous thrust of material which is hard to process under current process in a reversible manner and has lead to its accumulation in various strata of our planet. This has majorly led to

change in the seasonal shifts which were consistent from the century. Scientist has termed this phenomenon as the climate change. The two important phenomenon's under climate change are Global warming and ozone layer depletion. Due to electric power generation, transportation and various industrial processes there is a considerable increase in the amount of green house gases into the environment. These gasses act as a blanket for outgoing solar radiations and increase the amount of heat intake which is indicated by the rise in global average temperature. Past centuries have witnessed a drastic rise in this global average temperature of ocean and atmosphere and had lead to loss of many species and have increased the average sea level. With the raise in living standard in developed nations their dependence on modern air conditioners which uses the CFC's have lead to release of same into the atmosphere. These gases react with ozone layer in the stratosphere which saves earth from harmful solar UV radiations. This hole was first detected over Antarctica by NASA and is increasing in size with passing time. To combat climate change the UN formed an body UNFCCC (United nation framework Convention on Climate Change) in the year 1992 and conducted its first earth summit in Rio de Janeiro, Brazil. The aim of this organization is to combat the ongoing climate change. The organization signed the Kyoto protocol/Paris Agreement.

**II. LITERATURE SURVEY**

The process of solar energy conversions requires sunlight to fall on the cell and part of it is reflected by the solar surface. The sunlight falling on the system can only convert solar energy into electricity by motivating electrons and the hole pairs. In this process of charge collection fair amount of loses occur due to resistance loss by diffusion layer, resistance at the top of cell, busbar resistance and resistance of finger and silicon material.

In the following equivalent model,  $i_p$  is the constant current source, with a diode  $d$  connected across its terminals, along with a shunt resistance  $R_{sh}$  connected parallel to it and series resistance  $R_s$  connected in series.

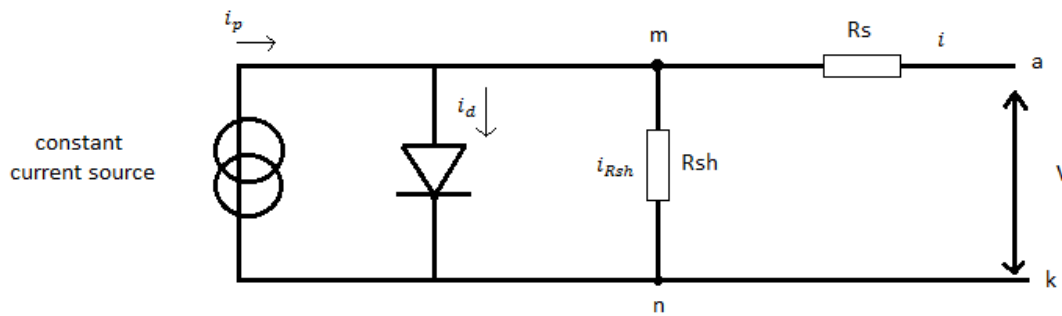

**Figure 1: Equivalent circuit model of a solar cell**

Here, Current  $i_p$  can be expressed as-

$$i_p = i_d + i_{R_{sh}} + i$$

$$i_p = \text{ConstantCurrentSource}$$

$i_d$  = Diode Current

$i_{R_{sh}}$  = Current Through Shunt Resistance,  $R_{sh}$

$i$  = Terminal Current

Now, the terminal current,  $i$ , can be expressed as-

$$i = i_p - i_d - (V + i * R_s) / R_{sh}$$

$R_{sh}$  = Shunt Resistance

$R_s$  = Series Resistance

$V$  = Voltage Across The Terminals

Now, the diode current, from the pn junction theory can be expressed as

$$i_d = I_0 (e^{\frac{V + i * R_s}{n * V_T}} - 1)$$

$I_0$  = Reverse Saturation Current

$V_T$ = Voltage Equivalent of temperature

$$V_T = \frac{kT}{q}$$

$$V_T = \frac{T}{11600}$$

$n$ = Ideality factor , =2 (depends on material, for silicon)

$k$ = Boltzmann Constant

$q$  =electronic charge in coulomb.

$I_0$  can be expressed as-

$$I_0 = k * T^m * e^{-V_{Go}/(n * V_T)}$$

$k$ = Boltzmann Constant

$m$ = 1.5 for Silicon

$V_{Go}$ = Equivalent Band Gap Energy

Here , in case of silicon

$V_{Go}$ = Forbidden band gap energy,

$E_{Go}$  (Measured in eV)

$V_{Go}$ = 1.16 to 1.21

So, the expression for terminal current  $i$ , will be-

$$i = i_p - I_0 \left( e^{\frac{(V+iR_s)}{n * V_T}} - 1 \right) - (V + i * R_s) / R_{sh}$$

**IV Curve of a solar PV cell**

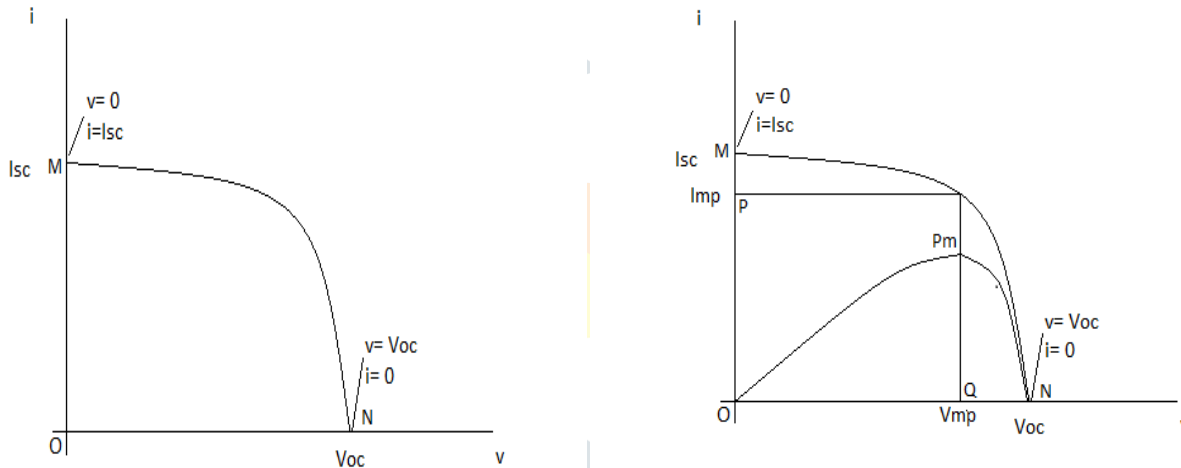

**Figure 2: I-V Curve of a solar cell** **Figure 3: I-V Curve, With current & Voltage at maximum power**

In case of short circuit we get the terminal current at point M,  $i = i_{sc}$ , here  $V=0$

$$i_{sc} = i_p - I_0 \left( e^{\frac{i_{sc} * R_s}{n * V_T}} - 1 \right) - I_{sc} * R_s / R_{sh}$$

here,  $R_{sh} \gg R_s$  also, the term  $I_{sc} * R_s / n * V_T$  tends to zero,

So the  $I_{sc}$  is equal to

$$I_{sc} = i_p \propto \text{Solar power insolation}$$

$I_{sc}$  will increase linearly with the incident solar power.

Now, at point N in the above graph, terminal current  $i=0$  and  $V = V_{oc}$

$$0 = i_p - I_0 \left( e^{\frac{V_{oc}}{n * V_T}} - 1 \right) - V_{oc} / R_{sh}$$

Since,  $R_{sh} \gg V_{oc}$  the term  $V_{oc} / R_{sh}$  becomes zero.

Now, on taking log,  $V_{oc}$  can be expressed as-

$$V_{oc} = n * V_T * \ln((i_p + I_0) / I_0)$$

There is a logarithmic relation between  $V_{oc}$  and  $i_p$ .

**Solar cell busbar:** Silicon solar cells are metalized with **thin rectangular-shape strips** printed on the front and back sides of a solar photovoltaic cell. These metallic contacts are called **busbars** and have a significant purpose: they **conduct** the direct current generated by the photoelectric effect of solar photovoltaic cell. Frequently, solar cell busbars are constructed from copper, coated with silver. The silver coating is necessary to **enhance** current conductivity (front side) as well as to **lower** oxidization (rear side).

**Parameters**

In solar cells/modules, the performance parameters are the following-

**Open Circuit Voltage Voc**

It is the maximum value of voltage that a solar module can produce. When the terminals of module are directly connected with the terminals of a volt meter, without any load applied to it, open circuit voltage is measured. Resistance is infinitely high and value of current is zero. It is abbreviated as Voc.

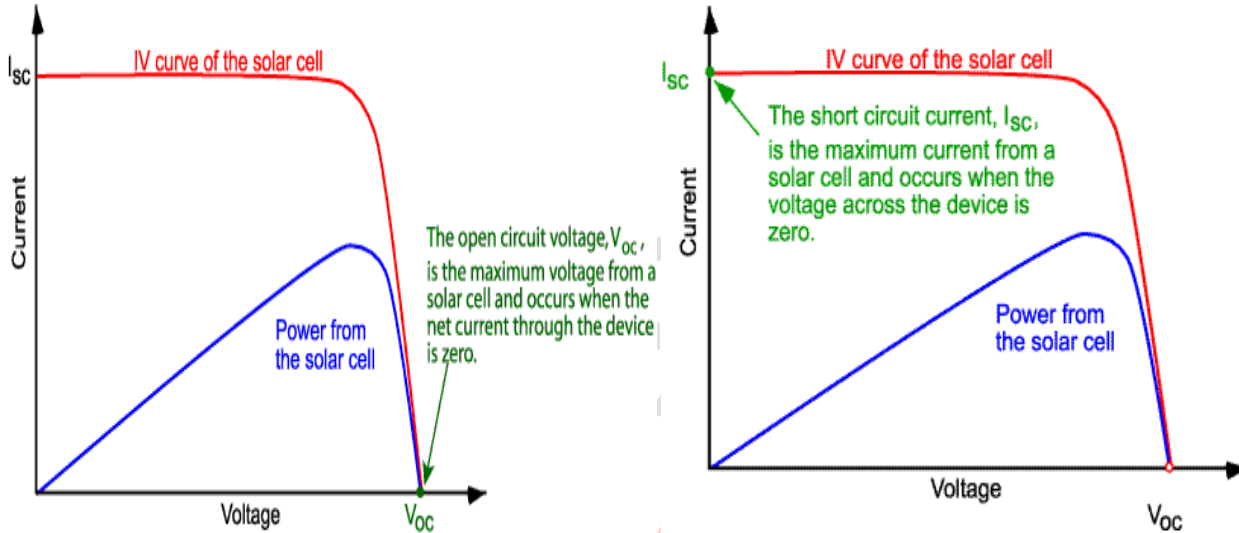

Figure 4: I-V Curve showing Voc Figure 5: I-V Curve showing Isc

**Short Circuit Current Isc**

Short circuit current is the maximum value of current that a solar module can produce. When the terminals of solar modules are shorted, the voltage in the circuit is zero and also the resistance. It is abbreviated as Isc.

**Voltage at maximum power point Vmp**

It is the voltage at maximum power point. Its value is less than Voc. Since the output of solar PV module depends on the amount of solar power insolation it receives, the value of Vmp changes with the change in solar insolation.

**Current at maximum power point Imp**

It is the current at maximum power point, its value is less than Isc. Since the output of solar PV module depends on the amount of solar power insolation it receives, the value of Imp changes with the change in solar insolation.

**Fill Factor FF**

Fill Factor is the ratio of maximum power output of a solar cell i.e. Vmp \* Imp to the product of voltage at open circuit and current at short circuit. Fill factor is the important parameter that shows the quality of solar cell, its value is less than 1. Ideal solar cells have fill factor = 1. But this is practically not possible. Solar cells of good quality have higher fill factor. Basically FF is the measurement of "squareness" of solar cell, good cells have square with large area while poor cell have small area means poor fill factor.

$$Fill\ factor = \left( \frac{V_{mp} * I_{mp}}{V_{oc} * I_{sc}} \right)$$

**Efficiency η**

Efficiency is the ratio of maximum power output of a solar cell to the maximum input power from sun. Efficiency of a solar cell can also be described as the part of sun's light energy converted into electrical energy by photoelectric effect. Standard solar insolation also known solar irradiance is = 1000W/m<sup>2</sup>

$$\eta = V_{oc} * I_{sc} * \frac{FF}{P_{in}}$$

where,

V<sub>oc</sub>- Open circuit voltage

I<sub>sc</sub> – Short circuit current

FF - Fill factor

P<sub>in</sub> = 1 Kw/m<sup>2</sup>\* Area of solar module.

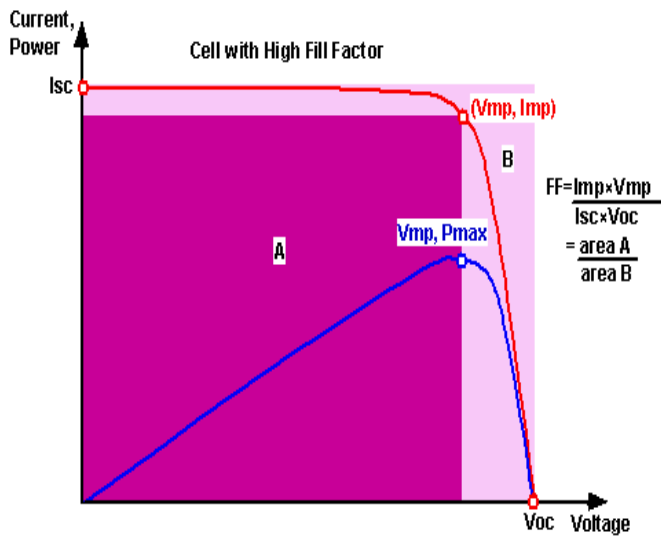

Figure 6 : Graph showing Squares of fill factor, cell with high fill factor.

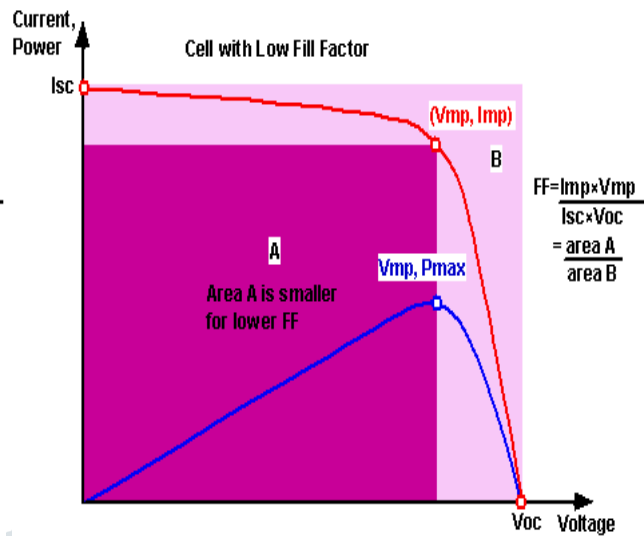

Figure 7 : Cell with low fill factor

Sangbo van et al have studied the effect of multi-busbar system on the efficiency and silver paste consumption. The electricity is wasted by the following kind of losses-diffusion layer resistance at the top of the cell, contact resistance of finger and silicon material, busbar resistance.

P rf	The finger resistance power loss
P sf	The finger shading power loss
P cf	The contact resistance of finger and silicon material power loss
P tl	The diffusion layer transverse current power loss
P rb	The ribbon resistance power loss
P sb	The ribbon shading power loss

Table 1: The power loss related to busbar and finger

The total power loss is equal to the sum of above six losses.

$$P\text{-Loss} = P_{rf} + P_{sf} + P_{cf} + P_{tl} + P_{rb} + P_{sb}$$

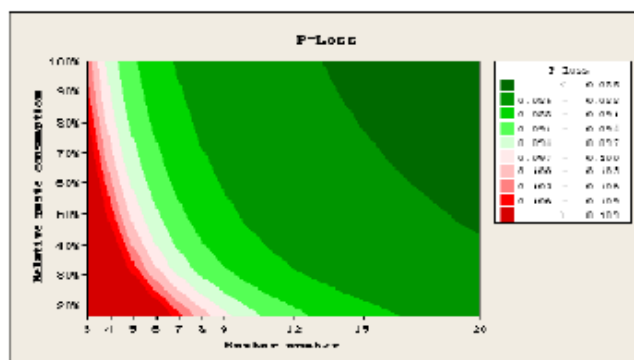
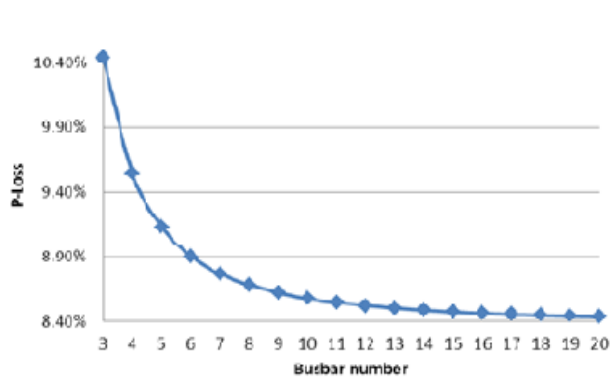
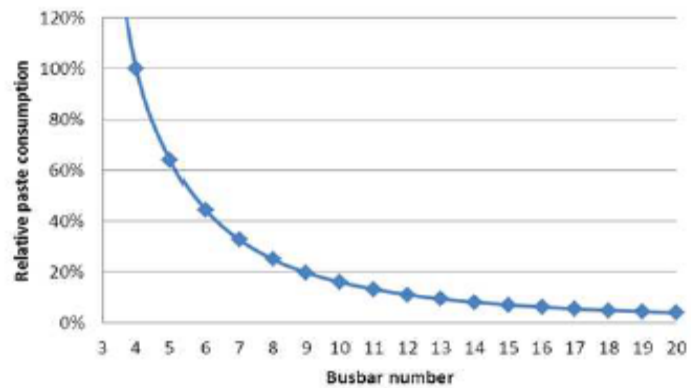

Figure 8: Power loss of finger resistance for different busbar number and different silver consumption

Power loss is inversely proportional to the square of the transmission distance along the finger length. The transmission distance is inversely proportional to the increase in number of busbar. Based on this principle, overall power loss will decrease with increase in number of busbar. There is a decrease of 85% in silver paste consumption when number of busbar are increased to 12.

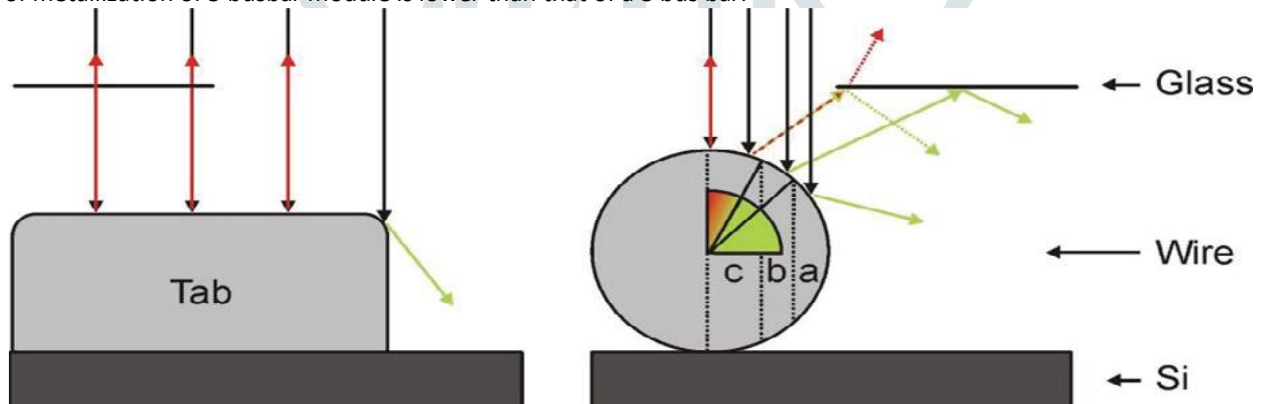

**Figure 9: For certain silver consumption, finger resistance power loss plotted over the number of busbar**



**Figure 10: To maintain the same finger resistance the required silver paste consumption plotted over busbar number**

J. Burschik et al (2016) have demonstrated the advantages of Ni/Cu/Ag plated cells when the number of Busbars were increased from 3 to 4 and 5. They have compared 3 busbar cells with 4 busbar and five busbars with respect to efficiency, finger and solder adhesion. They found that absolute efficiency can be increased by 0.15%, if the number of bus bar were increased from 3 to 4. They also concluded that the mass of metal deposited can be reduced by 30% for 5 bus bar compared to that of 3 bus bar module. Also the cost of metallization of 5 busbar module is lower than that of a 3 bus bar.



Stephen Braun et al. (2012) have discussed about the increase in the efficiency of solar cells having more than 3 busbar as widely used 3 busbar design for the solar cells as front electrode. They have used two diode model simulation program for comparing the results. There is an advantage of using multi busbar design which results in reduction of effective finger length. They found that multi busbar design of solar cell can increase the absolute efficiency of cell by 0.5%. Also there is reduction in the consumption of Ag paste by over 89% after using seed and plate techniques. They have used round wires instead of rectangular shape busbars, these round wires reflect additional sunlight into the cell, which leads to even higher current and efficiencies of this cell design.

Stephen Braun et al. (2013) in the paper have discussed about the losses which occur during stringing of cells in a module by using standard 3 busbar technology. They have discussed about the front side design by using more number of busbars than widely used three busbar designs for solar cell front electrode. The results they have achieved after simulation was that the multi busbar design allows higher cell and module efficiency, compared to a 3 busbar design also there is reduction in amount of silver paste needed for front electrode. They have achieved efficiency up to 19.5% with this multi-busbar design. With this multi-busbar design the reduction in silver paste for front electrode of more than 50% could be achieved. An additional silver reduction was achieved by replacing the rear side silver pads with the tin pads for the soldering process. This multi busbar gives the reduction in metallization cost and at the same time increases the efficiency.

Stefan Braun et al. have discussed about the increasing demand of solar PV modules at low rates leading to a new designing technique of solar cells. To increase the module efficiency primarily cell efficiency has to be optimized, they have worked on interconnected solar cell structure. They have investigated an easy to implement cell design where the number of busbar was varied to decrease the total series resistance of interconnected solar cells. Simulation program based on two diode model was used to determine the optimal efficiency, also a module with multi busbar has high potential in cost saving due to reduction in metal consumption for the front side metallization. Silver consumption of a multi busbar solar cell of size 6 inch is just 6.8 mg where a 3 busbar structure would consume 108 mg of silver paste.

Stefan Braun et al. have compared the solar cells of 3 busbar and multi busbar on the basis of module performance and silver metal consumption. In this comparison they have observed again a 0.6% absolute increase in fill factor on module level. They have used two diode module for simulation work. Reduction in silver metal consumption of about 50% absolute was achieved. Further they have discussed about the Ag seed and Ag LIP approach; techniques of front side metallization and with the help of these techniques there



is a further scope of reduction in Ag paste consumption. They concluded that a module with multi busbar design shows gain in fill factor and current density and reduction in consumption of Ag paste.

Nian Chen et al. have discussed about the reduction in cost of solar electricity that can be achieved by new advanced printing technology- inkjet printing. They have used model for optimization of solar cell, the model show that multi busbar design has less dependency on grid line height in contrast with the conventional 3 bus bar design. There is increase in efficiency of cell as the number of busbar increases. The optimal finger height of a 5 bus bar design is 20  $\mu\text{m}$  but its value increases for a 3 Bus bar cell and is more than 50  $\mu\text{m}$ . Also with the help of new printing technique there is a high potential of reduction in consumption of Ag paste.

Nian Chen et al. have compared the experimental results of Al-BSF Silicon solar cells with 3, 4 and 5 bus bars. They found that by keeping the same metal grid coverage, solar cells with 4 and 5 busbar gave higher fill factor and efficiency than 3 busbar solar cell. Also the value of grid line resistance decreases as the number of busbar increases from 3 to 4 and 4 to 5. The experimental data shows that there is an increase in efficiency of solar cell of about 0.41% absolute and 0.66 % absolute with 4 busbar and 5 busbar respectively. They achieved the best efficiency of 19.94 % for a 5 busbar cell.

Abasifreke Ebong et al. have discussed about the new innovative front grid design that is capable of -

- decreasing the metal shading,
- increasing the short circuit current,  $I_{sc}$ ,
- increasing the open circuit voltage,  $V_{oc}$ ,
- maintaining the fill factor, FF
- increasing the efficiency of solar cell

They have used innovative front grid design i.e. 4S-5BB, it uses less silver metal than conventional 3 bus bar.

New design shoes great potential for achieving 20% efficiency for AL- BSF Silicon Solar cell.

Abasifreke Ebong, et al have discussed about the advantages of inkjet metallization technique over the screen printing technique. The Upper Hand of inkjet metallization technique is the creation of precise grid line (width of 47  $\mu\text{m}$  and height of 45  $\mu\text{m}$ ), also by the help of this technique the amount of Ag paste dispensed per wafer (solar cell) is controlled. They have discussed about the precision of each grid line width and height, and due to this precision the Shading of front grid line was lower than the screen printed counterpart. They concluded that the cost of metallization can be reduced with inkjet printing Technology.

Shravan K Chunduri et al., have discussed about the innovative approaches to improve the PV panel efficiency independent from cell efficiency. They have discussed about the five major concepts-

- Glass module- in this they have replaced the backsheet with glass.
- Bifacial- in this they uncover the rear side of PV module for sunlight absorption.
- Half cut cells- by cutting a fully processed cell into two pieces, resistance losses can be reduced.
- Shingle modules- in this technique the solar cell is sliced into several strips so, it eliminates the role of connecting ribbons.
- Multi busbar Technology- one of the simplest ways to reduce resistance losses is to increase the number of busbars. This technology also results in reduction in amount of Ag paste used for front side metallization.

### III. CONCLUSION

Modern printing technology is entering into a phase where it is working on increasing the number of busbars. The research has been done on cellular level, module level and also using computational software. Result shows that this method increases the effi

### REFERENCES

- [1] Burschik J., et al. Transition to 4 and 5 BB designs for Ni/Cu/Ag plated cells. Energy Procedia. 98, 2016, p. 66-73
- [2] Braun, S., et al. Solar cell improvement by using a multi busbar design as front electrode. Energy Procedia. 27, 2012, p. 227-233
- [3] Braun, S., et al. Multi busbar solar cell and modules: high efficiencies and low silver consumption. Energy Procedia. 38, 2013, p. 334-339
- [4] Braun, S., et al. The multi busbar design: an overview. Energy Procedia. 43, 2013, p.86-92.
- [5] Braun, S., et al. High efficiency Multi busbar Solar cells and modules. IEEE Journal of Photovoltaics. 4. 2014, p. 148-153.
- [6] Chen, N., et al. Assessing the impact of multi busbar on metallization cost and efficiency of solar cells with digital inkjet printed gridlines. IEEE. 2013, p. 60-65.
- [7] Chen, N., et al. Towards 20% efficient industrial Al-BSF silicon solar cell with multiple busbar and fine gridlines. ELSEVIER. 146, 2016 p. 107-113.
- [8] Ebong, A. et al. Innovative front grid design, Four street and Five busbar(4S-5BB), for high efficiency industrial Al-BSF silicon solar cells. IEEE. 37, 2016, p. 459-462.
- [9] Ebong A., Understanding the uniqueness of of the inkjet metallization of multicrystalline silicon solar cell. Japanese Journal of applied physics. 54, 2015.
- [10] Chunduri, S., et al. Advanced solar module technology. Asian Photovoltaic Industry Association. 2017.
- [11] Wan, S., et al. The design and industry road of a low cost and high efficient multi busbar technology. 32<sup>nd</sup> European Photovoltaic Solar Energy Conference and Exhibition. 2016 p. 907-914.
- [12] Zemen, Y., et al. The impact of busbar surface topology and solar cell soldering process. 27<sup>th</sup> European Photovoltaic Solar Energy Conference and Exhibition, 2012. p. 2030-2034

- [13] Koduvelikulathu, J., et al. Why Multi busbars and future emitters require further shrinking of finger line width. 32<sup>nd</sup> European Photovoltaic Solar Energy Conference and Exhibition 2016. p. 550-554.
- [14] Upadhyay, A., et al. Solar Energy fundamentals and challenges in Indian restructured power sector. IJSRP, vol. - 4, 2014
- [15] Xie, Y., et al. Performance of multi busbar PV modules. 33<sup>rd</sup> European Photovoltaic Solar Energy Conference and Exhibition. 2017. p. 1639-1642.
- [16] Hoger, I., et al. Boosting module power by advanced interconnection and p-type Cz silicon solar cell efficiencies exceeding 22% in mass production. The 8<sup>th</sup> International Conference on Crystalline Silicon Photovoltaics, AIP Conference proceedings. 2018, p. 110003(1-6).
- [17] Yang, Y., et al. An improved busbar design to save the cost of PV modules: Experiment and Simulation. 26<sup>th</sup> European Photovoltaic Solar Energy Conference and Exhibition. 2011..p. 1620-1622.
- [18] Dullweber, T., et al. Fine- line printed 5 busbar PERC solar cells with conversion efficiencies beyond 21 %. 29<sup>th</sup> European Photovoltaic Solar Energy Conference and Exhibition. 2014. p. 621-626.
- [19] Pysch, D., et al. Advantages of transition to four and five busbar front contact grid designs for Ni/Cu/Ag plated silicon solar cells. 32<sup>nd</sup> European Photovoltaic Solar Energy Conference and Exhibition. 2016. p. 796-800.
- [20] International Technology Roadmap For Photovoltaics(ITRPV), <https://www.itrpv.net>
- [21] Mette, A., New Concepts for Front Side Metallization of Industrial Silicon Solar Cells. Ph.D Dissertation. Freiburg. Germany . 2007.

