

Industries Faults Detection with GSM Using IoT

Bhandavya H G¹, Shilpa Biradar²

¹Student, Dr.Ambedkar Institute of Technology, Bangalore,

²Assistant Professor, Dr.Ambedkar Institute of Technology, Bangalore.

ABSTRACT

Security and automation could be a prime concern in our everyday life. The approach to industrial automation and security system design is almost standardized nowadays. To increase these standards by combining new design techniques and developed a low cost industrial automated security systems. Everyone wants to be as much as secure as possible in the industries environment. The design of simple hardware circuit enables every user to use this wireless Industries security system with IR sensor, Gas sensor, Fire sensor, GMS, GPS, Camera and send SMS alert to owner specified Mobile number and announcement when fault detected in the Industries.

Keyword: IR sensor, Gas sensor (MQ-2), Fire sensor, GMS, GPS, Android phone.

I. INTRODUCTION

Nowadays, Industrial security is the prime concern for an individual. The owner look for ways to protect their personal space and enhance their habitation values fault and robbery or theft occurs in the industry and any intrusion into the industry. The Security system alerts the security personnel as well as the owner by sending SMS alerts to the users of the industry. These systems are difficult to maintain. Hence the proposed system uses GSM module which supplies the real time security status of home/industry when the user is away from home/industry. GSM technology is used to speak input signal from appliances to output message on device. The system is fully controlled by microcontroller. All the sensors and detectors are interconnected to microcontroller using various interfacing circuits. The microcontroller continuously monitors all the sensors and is it senses any abnormal condition then the microcontroller will send the SMS to the user through GSM module. All the sensors will be activated and the reason for insecurity will be displayed on the LCD interfaced to the microcontroller.

1.1 PROPOSED SYSTEM

The proposed system is used to monitor the gas (air pollution) detection and prevention of gas leakage when detect exhaust fan will be on, fire detection and prevention fire or smoke, oil low level detection when oil in machine below the threshold level (i.e, 50%), The GPS is used for track location in the industry, when the intruder found and, it also captures the intruder photo and sends the photo to the register Email Id. The GSM modem is used to collect the information and sends that information to the user mobile in text format. The relay is used for bulb on/off and charger on/off or fan on/off.

ADVANTAGES OF PROPOSED SYSTEM

1. Proper industrial monitoring & controlling
2. Effective remote monitoring of industrial processes
3. Prevent accidents from occurring due to excessive gas(air pollution), fire, oil low level, location & photo capture
4. Reduces manual process of monitoring & verification
5. System can be accessed anytime and from anywhere.
6. Real-time data transmission and access.
7. The cost & effort are less in this system.

II. RELATED WORK

“Fire- Detectors Review and style Of An Automatic Quick Responsive Fire-Alarm System Supported On SMS” [1] To review of existing fire-detector varieties has been dispensed at the side of the event of a low price and consistently good in quality or performance of microcontroller based automated fire alert alarm system for remotely alerting any fire incidents in household or industrial premises. The system was designed to alert the distant property-owner efficiently and quickly by sending short message service (SMS) via GSM network.

III. METHODOLOGY

b. Receiver Section:

3.1 SYSTEM ARCHITECTURE

a. Transmitter Section:

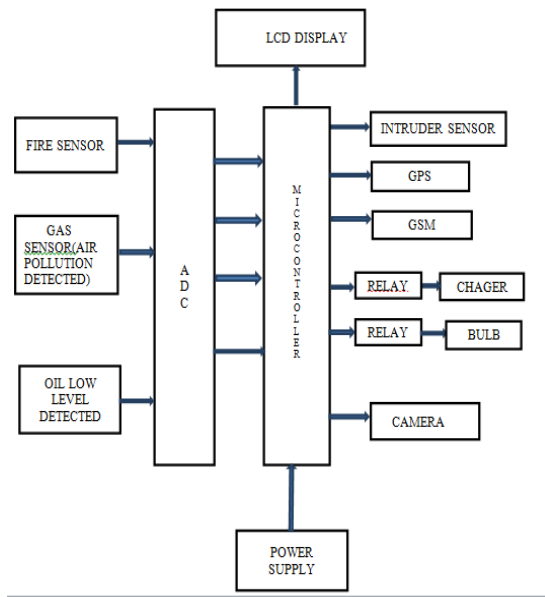

Fig 3.1(a) Block Diagram



Figure 3.1(b) : Receiver Section Architecture

1. The user will receive the notification messages in both text and audio alert format.

3.2 IMPLEMENTATION

a. INTRUDER SENSOR

The block diagram working as below:

1. When the power supply is given first, Fire sensor will detect the fire in the industry and send the notification "FIRE DETECTED".
2. Gas sensor will detect the gas leakage (air pollution) in the industry and send the notification "GAS DETECTED".
3. After that, the Oil level machine will check whether the oil level is low and gives the result "OIL LEVEL IS LOW" to the user to fill the oil tank.
4. IR sensor will detect the intruder in the field and sends the notification "INTRUDER DETECTED".
5. The GPS is used for track location in the industry, when the INTRUDER FOUND.
6. And, it also captures the intruder photo and sends the photo to the register Email Id.
7. The ADC converter is used to convert analog signal to digital values.
8. The LCD is used for display the message.
9. The GSM modem is used to collect the information and sends that information to the user mobile in text format.
10. The relay is used for bulb on/off and charger on/off or fan on/off.



An infrared sensor is an electronic element, that emits in order to sense some aspects of the environments. An IR sensor can measure the heat of an object as well as detects the motion. IR sensors are best for the basic projects that need to sense when a person passes by or leaves the area. They have low price and low power, have wide selection and straightforward to interface. The detection range of IR sensor is up to 20 feet (6 meters). The power supply range is about 5V to 12 V.

b. FIRE SENSOR



The Fire detection system makes use of sensors of the LM35, the LM35 is used to detect the presence of flame in the surrounding and the signal gotten from these sensors are sent to the microcontroller and the status of the system is displayed on an LCD. With the help of the GSM module, the system sends SMS alert to the owner phone number telling the user the status of the environment whether a fire is detected in the Industries surroundings.

c. GAS SENSOR



The Gas Detection system use the sensor of the MQ-2, the MQ-2 is used to detect the presence of Gas leakage (air pollution) and the signal gotten from the sensor are sent to the microcontroller and the status of the system is displayed on an LCD. With the help of the GSM module, the system sends SMS to the owner phone number telling the user the status of the environment whether a gas is detected in the industries surroundings.

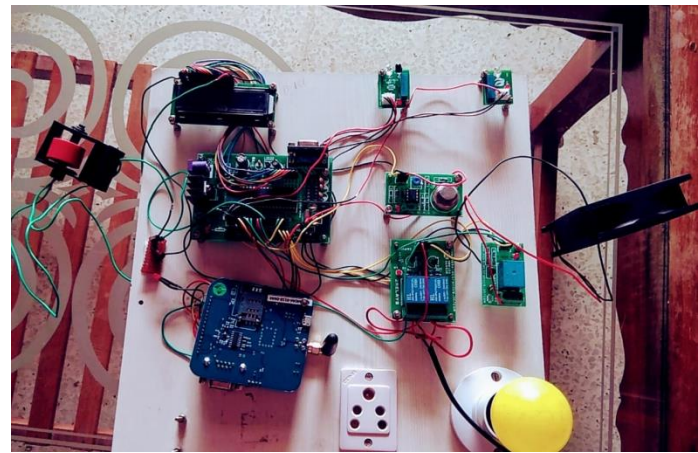

The model implemented for Industry monitoring using microcontroller and different sensors.

d. OIL LOW LEVEL DETECTION

In industry machine engine has lost oil pressure, or the oil level is too low. Auto technicians will determine the cause of the oil warning alert. And the signal gotten from the sensor are sent to the microcontroller and the status of the system is displayed on an LCD. With the help of the GSM module, the system sends SMS to the owner phone number telling the user the status of the environment whether a oil low level is detected in the industries surrounding.



b. FIRE DETECTION

e. LOCATION USING GSP

The GPS is used for track location in the industry, when the INTRUDER FOUND. And the signal gotten from the sensor are sent to the microcontroller and the status of the system is displayed on an LCD. With the help of the GSM module, the system sends SMS to the owner phone number telling the user the status of the environment whether a location in the longitude and latitude in the industries surrounding.



c. AIR POLLUTION DETECTION

f. PHOTO CAPTURE

It captures the intruder photo and sends the photo to the register Email Id.

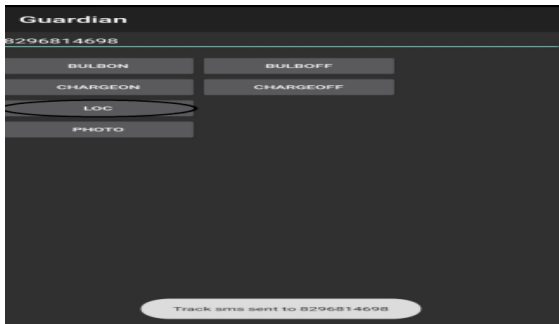
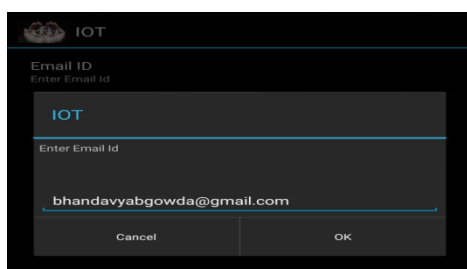

d. OIL LOW LEVEL DETECTION**e. DETECTION OF LOCATION****d. PHOTO CAPTURE****V.APPLICATIONS**

- 1) Protection from any gas leakage in cars
- 2) For safety from gas outflow in heating gas fired appliances like boilers, domestic water heaters
- 3) Large industries which uses gas as their production
- 4) For safety from gas leakage in cooking gas fired appliances like ovens, stoves etc.

VI. ADVANTAGES

- 1) It is used in house as gas leakage detection
- 2) The sensor has excellent sensitivity combined with a quick fast response time.
- 3) The system is highly reliable, tamper-proof and secure.
- 4) In the long run the maintenance Price is very less when Compared to the present systems.
- 5) It is possible to get instantaneous results and with high accuracy.

VII. CONCLUSION AND FUTURE ENHANCEMENT

Detection system for gas leakage, fire detection, oil low level detection, location and photo capture is proposed. When gas leakage (air pollution) occurs and automatically switching on of exhaust fan will take place in the system controlled pollution. Fire detection used detect the fire in the industry and oil low level detection used detect oil low level below the threshold value .All these sensors senses the detection and sends an alert SMS to registered user.

Multiple sensors could be included systematically to cover wider range, or sensor with higher range coverage could be developed for the purpose of the system.

REFERENCES

- [1] ArunKumar.G.A. Rajasekhar.K., Satyanarayana.B.V.V., and SuryanarayanaMurthy.K, "Implementation of Real time Detection of Gas leakage in Industries using ARM7 & Zigbee", International Journal of Engineering Research & Technology, Vol .1, Issue 7, pp 1-4, Sep 2012.
- [2] Ashish S, Ratnesh P, Rajeev K, Rahul V (2013). "GSM Based Gas Leakage Detection System" International Journal Of Technical Research And Application. Pp.42-45.
- [3] ShaikDr.Meeravali and Anusha, "Detection Of Gas Leak And Its Location Using Wireless Sensors", Vol.1, Issue 9, pp.1-8, November 2012.
- [4] ArnoldoDíaz-Ramírez, Luis A. Tafoyaa, Jorge A. Atempa, and Pedro Mejía-Alvarezb, "Wireless Sensor Networks and Fusion Information Methods for Forest Fire Detection," in Science direct on Electronics Engineering and Computer Science ', 2012, pp.69-79.