

# 3R REGENERATION USING COMPENSATION TECHNIQUES

Suman Sharma<sup>1</sup>, Simranjit kaur<sup>2</sup>

<sup>1, 2</sup> Department of Electronics and communication

sri sai college of Engineering and technology Badhani, Pathankot

## Abstract

The ever ending need for high data rate and speed for the communication lead to the evolution of optical communication. A communication network in current scenario must provide seamless and errorless connectivity. One of the major component used for this purpose is regenerator for long haul communication. The latest evolution of 3R generator has a bottleneck of OEO conversion, therefore, there is a need for an all-optical 3R regenerator. The 3R performs reshaping, retiming and reamplification on data pulse. This paper deals with techniques and implementations of reshaping, retiming and reamplification as one unit module for point to point link establishment. This above integration results in reducing jitter, high data rate support and improvement in of bit error rate. The work will be supported by simulation and practical implementation result using optic-wave system software.

**Keywords** optical amplifier, EDFA, Fiber Bragg grating, dispersation compensation

## 1.Introduction

when the bit rate of optical network systems increases to higher than 80 Gb/s, all-optical signal processing technologies are expected to be one of the key solutions to accelerate the actual deployment of higher speed network systems due to the limitation of the operation speed of the electrical components. In an all-optical signal processing technology, an all optical 3R (reamplifying, reshaping, and retiming) regenerator is one of the key components in the points of enhancement of scalability and flexibility of the all-optical wavelength division multiplexing (WDM) network. In addition, in order to enhance the all-optical WDM network more, smaller excess penalty, less polarization dependency, and more stable performance are also necessary for all-optical 3R regenerators.[1] For realizing such all-optical 3R regenerators, various methods of optical 2R (reamplifying and reshaping) and 3R regenerators have been proposed and demonstrated so far based on electro absorption modulator, semiconductor optical amplifiers (SOAs), and highly nonlinear fiber (HNLf)[2].

This lead to the motivation of this paper and formulated problem statement of this paper is All-optical 3R regenerator to be realized with Reamplification, Reshaping and Retiming features for power efficient, and simple optical integrated network component. This system must lead to high data rate, less jitter and improved BER optical signal transmission.

## 1.1Methodology

### 1.1.1 Optical Amplifier

In optical fiber communication, when the signal is desired to be transmitted to a long transmission distance, there will be degradation. To overcome that drawback in the optical fiber, optical amplifiers are used [3]. They are designed to amplify the transmitted optical signal without converting the signal into the electrical form. In linear mode, the optical amplifiers are used as repeaters. However, in nonlinear mode, the optical amplifiers are used as optical gates, routing switches, and pulse sharpeners. In WDM light wave system, the optical amplifiers are used to amplify all the channels at the same time and that process can be named as optical in-line amplifiers [3]. The optical amplifiers are also able to amplify signals at

different wavelengths at the same time. Power booster can be created on the optical amplifier that increases the transmitted power by installing the optical amplifier immediately after the transmitter [3]. On the other hand, optical preamplifier can be created on the optical amplifier that increases the received power and increases the transmission distance by installing the optical amplifier just before the signal reaches the receiver [3].

### 1.1.2 Types of Optical Amplifiers:

It is mainly used to amplify an optical signal directly, without the need to first convert it to an electrical signal. There are many types of optical amplifiers, namely Raman amplifiers, erbium doped fiber amplifiers (EDFAs), and semiconductor optical amplifier (SOA). Firstly we will discuss introduction to SOA amplifier, and analyze its advantages and disadvantages.

### 1.2 The Basics of Semiconductor Optical Amplifier (SOA)

SOA optical amplifiers use the semiconductor as the gain medium, which is designed to be used in general applications to increase optical launch power to compensate for the loss of other optical devices. Semiconductor optical amplifiers are often adopted in telecommunication systems in the form of fiber-pigtailed components, operating at signal wavelengths between 0.85  $\mu\text{m}$  and 1.6  $\mu\text{m}$  and generating gains of up to 30 dB. Semiconductor optical amplifier, available in 1310nm, 1400nm, 1500nm, 1600nm wavelength, can be used with single mode or polarization maintaining fiber input/output[4]

#### 1.2.1 Key Points of SOA Amplifier

- 1310 nm, 1400 nm, 1550 nm and 1610 nm wavelength selectable
- A high fiber-to-fiber gain of 20 dB
- Up to 16 dBm output
- 1 MHz with 10 ns pulse width (optional)
- PM Panda fiber input/output (optional)
- Similar to lasers, but with non-reflecting ends and broad wavelength emission
- Incoming optical signal stimulates emission of light at its own wavelength
- The process continues through the cavity to amplify the signal

#### 1.2.2 The Basics of Erbium-doped Fiber Amplifier (EDFA)

Erbium-doped Fiber Amplifier, is the most deployed optical amplifier in the WDM system that uses the Erbium-doped fiber as optical amplification medium to directly enhance the signals. The amplifying medium is a glass optical fiber doped with erbium ions. The erbium-doped fiber gain medium amplifies light at wavelengths that are in the neighborhood of 1550 nm—the optical wavelengths that suffer minimum attenuation in optical fibers. EDFA works best in the range 1530 to 1565 nm, and it possesses low noise and can amplify many wavelengths simultaneously, making it the fiber amplifier of choice for most applications in optical communications.

#### 1.2.3 Fiber Bragg grating Fiber Bragg Grating

(FBG) is very simple and low cost filter for wavelength selection which has various applications to improve the quality and diminish the costs in optical networks [5]. FBG executes some operations like reflection and filtering with high efficiency and low losses. FBG acts as a dispersion compensator in transmission optical system which is used to compensate chromatic dispersion. Thus, the final expected effect is compression in incident pulse and can be appropriate to compensate chromatic dispersion in a communication link. FBG is single mode which will expose the core to the periodic pattern of intense ultraviolet light. The exposure will increase the refractive index and thus the refractive index is permanently increased. Then the exposure pattern will create a fixed index modulation that called grating. When periodic refraction is changed, a small reflected light will be produced. Then, the small reflected light will be combined into a large reflected light at a certain wavelength [5].

### 1.3 Dispersion Compensation

In order to remove the spreading of the optical or light pulses, the dispersion compensation is the most important feature required in optical fiber communication system. Dispersion is the pulse distortion accumulation over fiber optic transmission. By invent of EDFAs, there was no need to use regenerators. EDFAs provided large gain, but they could not clean up the incoming signal. Dispersion and nonlinear effects accumulate as a result. Chromatic dispersion is a result of the dependence of the refractive index on the wavelength [6]. Due to the refractive index change, different frequency components of the light wave experience different phase delays. The phase difference causes distortion on the signal. Waveguide dispersion results from the geometric properties of the fiber. By compensating for each other's Effects, a dispersion-shifted fiber can be produced with a 0 ps/nm.km dispersion at the minimum loss wavelength = 1.55 m. Dispersion inhibits the effects of nonlinearities like self-phase modulation (SPM), cross-phase modulation (XPM) and four-wave mixing (FWM). Therefore, dispersion should be non-zero instantaneously, 0p dispersion should be zero at the receiving end, in the long run. This puts the constraint into design of dispersion compensation techniques [6].

#### 1.3.1 Dispersion compensation schemes

- i. Pre-compensation
- ii. Post-compensation
- iii. Symmetrical-compensation

### 1.4 Simulation

In this Chapter we investigated that Comparative Analysis of 3 R regeneration Using Erbium Doped Fiber Amplifiers/Fiber Raman Amplifiers (EDFA/FRA)

#### 1.4.1 Introduction

OptiSystem Simulator is an innovative optical communication system simulation package that designs, tests, and optimizes virtually any type of optical link in the physical layer of a broad spectrum of optical networks, from analog video broadcasting systems to intercontinental backbones. It possesses a powerful new simulation environment and hierarchical definition of components and systems. Its capabilities can be extended easily with the addition of user components, and can be seamlessly interfaced to a wide range of tools. OptiSystem allows for the design automation of virtually any type of optical link in the physical layer, and the analysis of a broad spectrum of optical networks, from long-haul systems.

### 1.5 Description of components

RZ pulse generator has an advantage on controlling bandwidth. This is due to the characteristic of the generator that the returning signals to zero between bits. Pseudo-random bit sequence generator is used to scramble data signal in terms of bit rates. Mach-Zehnder Modulator (MZ) has two inputs (optical signal and electrical signal) and one output (optical). Then the input signal is modulated with semiconductor laser that is represented by Continuous Wave (CW) laser Frequency 1555.1 nm through Mach-Zehnder modulator. Continues laser diode (CW) to generate optical signals supplies input signal with 1550 nm wavelength and input power of 10dBm which is externally modulated at 10 Gbits/s. with a Gaussian pulse generator pseudorandom binary sequence in a Mach-Zehnder modulator with 30 dB of extinction ratio. The optical fiber used is single mode fiber because has higher data rate and long distance transmission. The fiber Bragg grating is used as the dispersion compensator. The FBG length 6 mm Photo detector (PIN) Diode Positive Intrinsic Negative to translate the optical signal into an electrical signal.

### 1.6 Design consideration

The system is operated with the basic optical communication which consists of a transmitter, transmission link and a receiver. The system transmits information using optical carrier wave from transmitter to receiver via optical fiber. The input signal contains electrical data that is represented by 0's and 1's has been generated by return-zero (RZ) pseudorandom binary sequence. Then the input signal is modulated with semiconductor laser that is represented by Continuous Wave (CW) laser through Mach- Zehnder modulator. CW laser supplies input signal with 1550 nm

wavelength and input power of 10.5556dBm which is externally modulated at 10 Gbits/s with a return-zero (RZ) pseudorandom binary sequence in a Mach-Zehnder modulator with 30 dB of extinction ratio. The optical fiber used is single mode fiber because single mode fiber can yield higher data rate, less dispersion and also can operate in long haul distance, so it is suitable to be used as transmission link. For the dispersion compensator, the fiber Bragg grating will be used. The length grating that will be used is 6mm since the most proper length for proposed model is equal to  $l = 6$  mm by try and error method. After dispersion compensation the signal will pass through optical amplifier that represented by Erbium-doped fiber amplifier (EDFA). Optical amplification is required to overcome the fiber loss and also to amplify the signal before receive by Photo detector PIN at the receiver part. The initial settings for the design are shown in Figure2. order to operate as the optical transmission system: Input power 10.5556 Db, Reference wavelength 1550nm, DCF 15km, SMF 30km optical attenuator bandwidth 500Ghz.

Table 1 3R regeneration optical simulation parametric values

Side	Component	Parameter	Value
Transmitter	RZ Pulse Generators	Amplitude	1a.u.
		Rise Time	0.05 bit
		Fall Time	0.05 bit
	CW Laser	Frequency	1555.3 nm
		Power	10.5556dBm
	Mach zehnder	Extinction Ratio	30 dB
Channel	Semiconductor Optical Fiber	Length	20, 30, 35, 40, 60,80, 100,
		Attenuation	0.25 dB/km
		Dispersion	16.75ps/nm/km
	Optical attenuator	Bandwidth	500 Ghz
Receiver	PIN Photo detector	Responsivity	1 A/W
		Dark Current	10nA
	Bessel Filter	Cutoff Frequency	0.75*Bit rate Hz

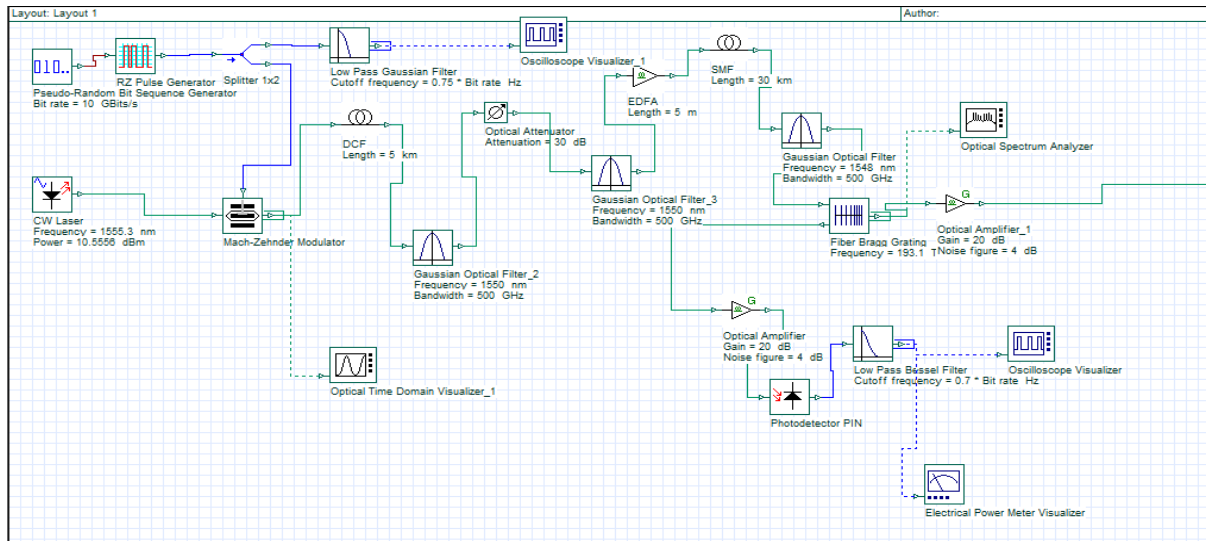

Figure 1: Simulation setup

Table 2 Different cases for variation of single mode and dispersion compensation fiber

Case	DCF (KM)	SMF (KM)
1	5	10
2	6	12
3	8	15
4	10	20
5	10	25
6	10	30
7	15	30
8	15	50
9	15	60

Table 3: The output readings are tabulated by varying the OFC Length (km):

G bit/sec	Q-Factor	Extinction ratio	Eye opening
1	28.8746	26.6537	96.5367
2	21.6843	26.2028	95.3884
5	32.9802	30.3178	96.9679
10	24.9912	23.1567	95.9986
30	2.40088	1.73755	58.3485

### 1.7 Result and Discussion

The simulation and optimization of the design is done by OptiSystem simulation software. The eye diagrams and results of output power (dbm) noise figure(db), gain(db) and Q-factor(db) and same length of FBG (mm). The related graphs and Tables are also plotted:

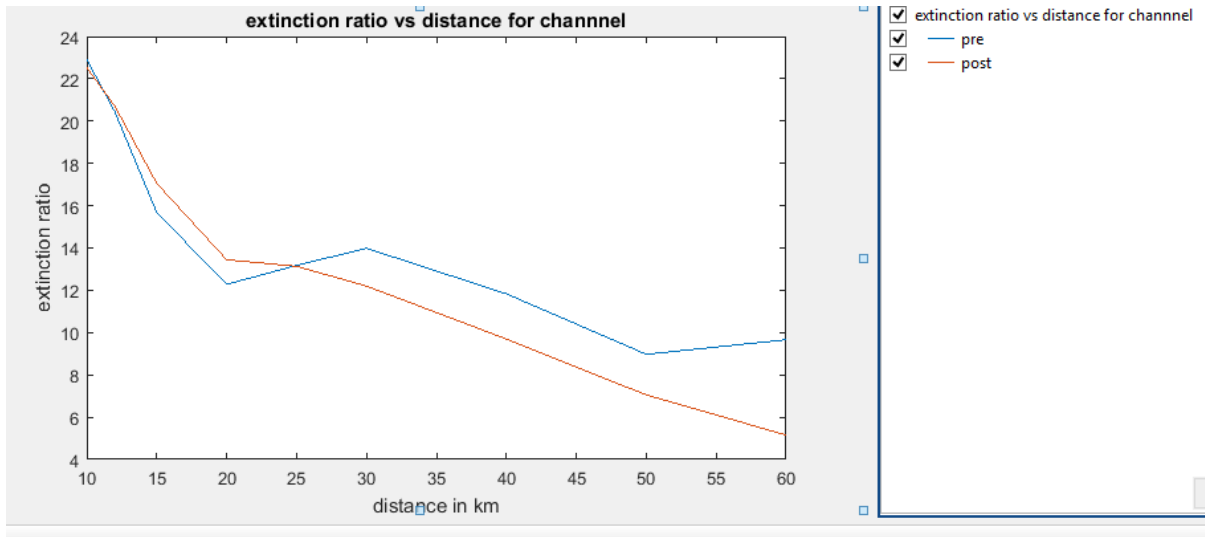

Figure 2: Graph of extinction ratio versus length (km) using pre and post technique

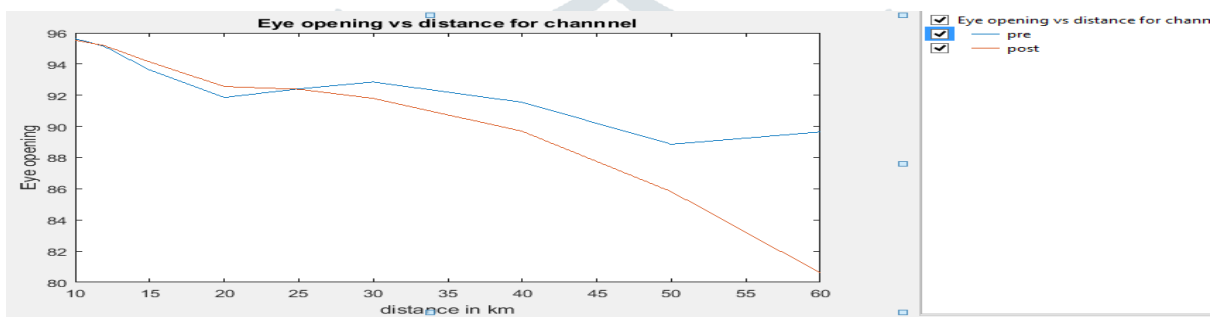

Figure 3: Graph of Eye opening versus length (km) using pre and post technique

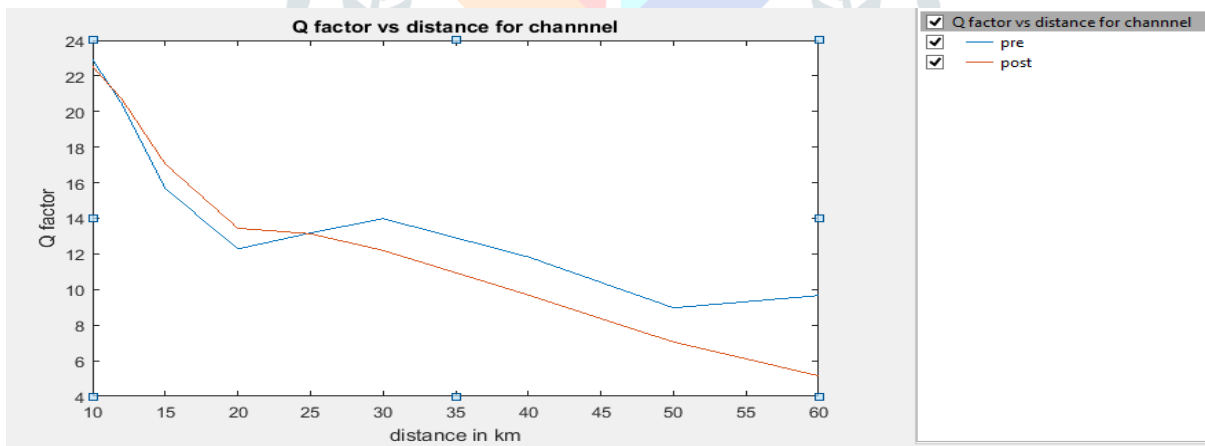

Figure 4: Graph of Q factor versus length (km) using pre and post technique

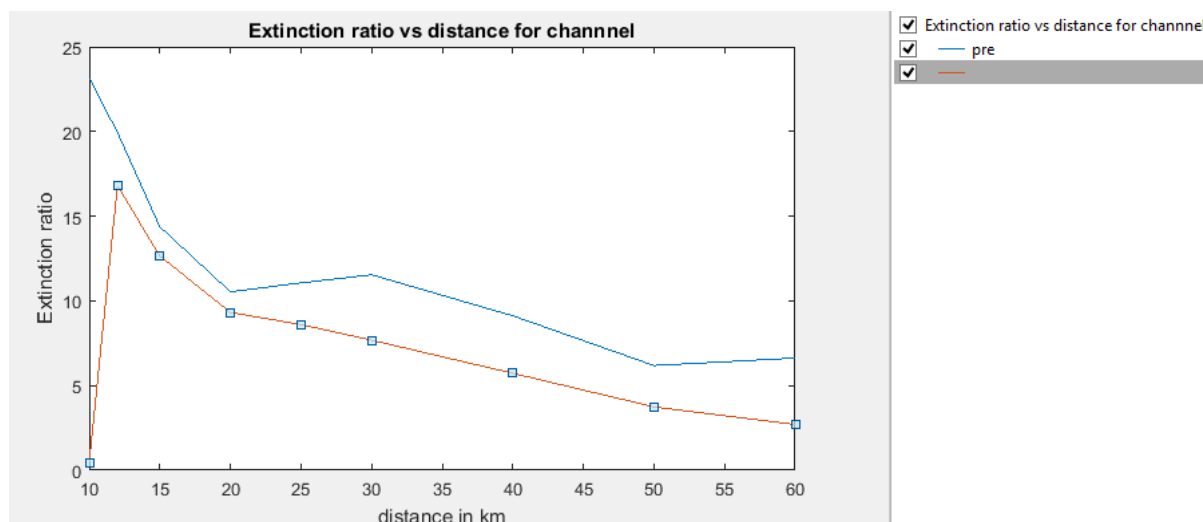

Figure 5: Graph of extinction ratio versus length(km) using pre and post technique

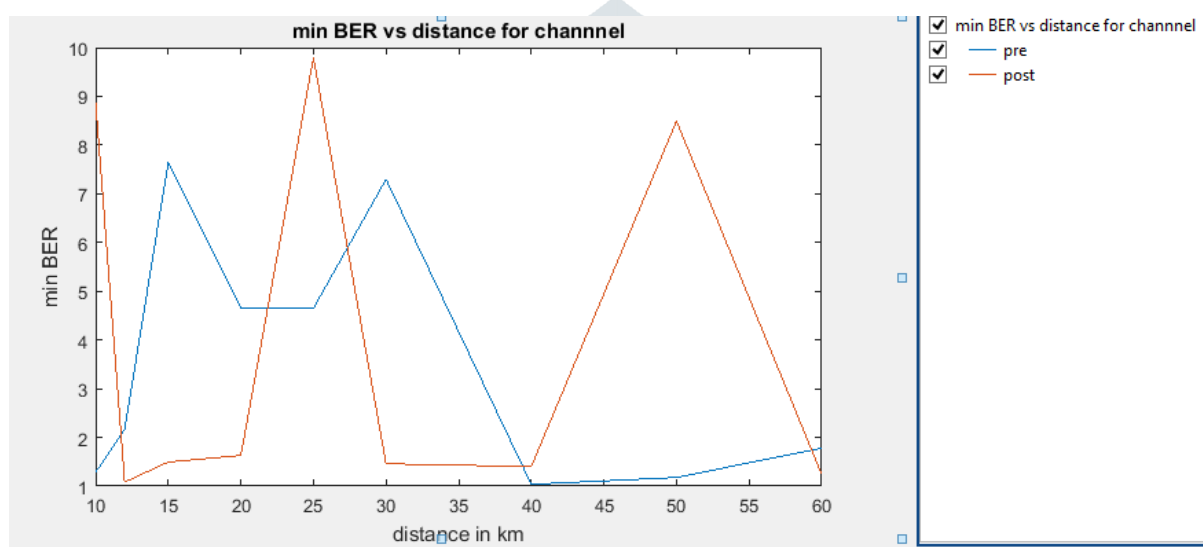

Figure 6: Graph of Min BER versus length (km) using pre and post technique

### 1.8 inferences:

Fig. 6 is the simulation result for simplex link stability against loss over link length. we can conclude that at high frequency operations trivial attenuation loss leads to enormous information loss, hence the attenuation must be mitigated using repeater or amplifiers. The min Q factor of 28.8746 is achieved at Loss = 26.6537 dBm for 1 Gb/s with BER = 2.42362e-081.

Loss = 26.6843 dBm for 2Gb/s with BER = 2.58166e-036.

Loss = 32.1567dBm for 5 Gb/s with BER =2.08512e0

Loss =23.1567 dBm for 10 Gb/s with BER =2.08512e-027Bmm

For current scenario multimedia high data rate 40 Gb/s and above bit rate system must be realized, for above purpose some compensation technique must be employed for achieving min Q factor for transmission link of such high data rate. Fig. 7,8,9 is the simulation result for amplified point to point link showing inclusion of amplifier in the communication link on considering repeater spacing, improved BER of the system. The system is loss resistant for longer link length i.e. initially the communication for 1,2, 5 and 10 Gb/s data rate became unrealizable at 26, 26, 32 and 23 dBm loss but on amplification it was stable up to 39,38,32 and 31 dBm. Since we should also consider the shape of the received signal for decoding information optical time domain visualizer was used to view it as shown in Fig 7 and Fig 8 and 9 is pulse shape of transmitted and received signal for FBG compensated 3R Regenerator The dispersion is very less compared to the pulse size but that also must be mitigated since loss of some nanosecond or Picosecond information is also a high loss of information data at high data rates. The major factor that effects optical communication is dispersion, which is cumulative in nature i.e. as length of the link increases its effect increases. This effect must also be considering as it leads loss of information due to overlapped symbols. In 1R system this is not mitigated hence leading to requirement of 2R, another being higher data rates. On implementation of 2R regenerator using FBG fibre compensation in the transmission line higher data rates are be achieved for same link parameters as

shown in Fig. 9 i.e. at 40 Gb/s dispersion compensated transmission link can be established with min Q factor of 11.8329. For reshaping of signal time jitter must also be compensated. Therefore, there is need for clock recovery in the transmission link. Higher data rate system can be achieved on clock recovered transmission link as shown in Fig. 9 but there is a constraint that all bit generators must have same frequency of operation. This increases complexity for operation because if the frequencies are not aligned then system becomes unstable. For clock recovery the locally generated signal frequency is estimated by assumption hence there is always a probability of misalignment in the transmission link. This leads to the need of 3R regenerator. O-E-O conversion requires more cost and power, hence Design of all optical regenerator system mitigates this disadvantages.

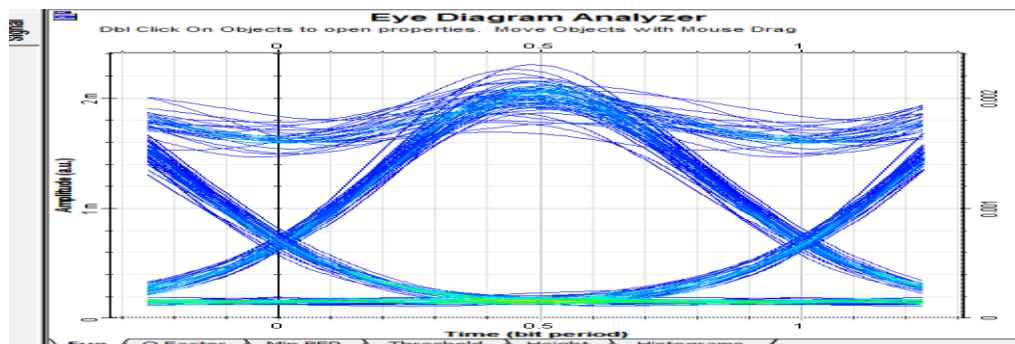

Figure 7: Eye diagram analyzed in pre compensation technique

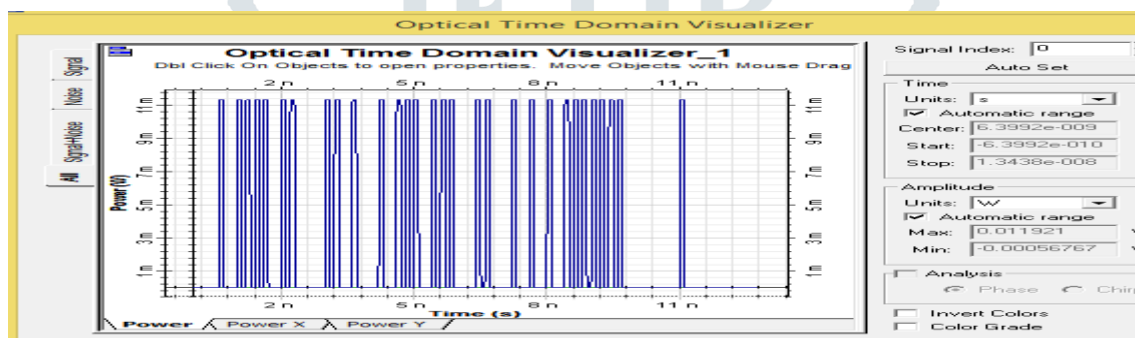

Figure 8: Generated signal for 5 Gb/s. using pre compensation technique

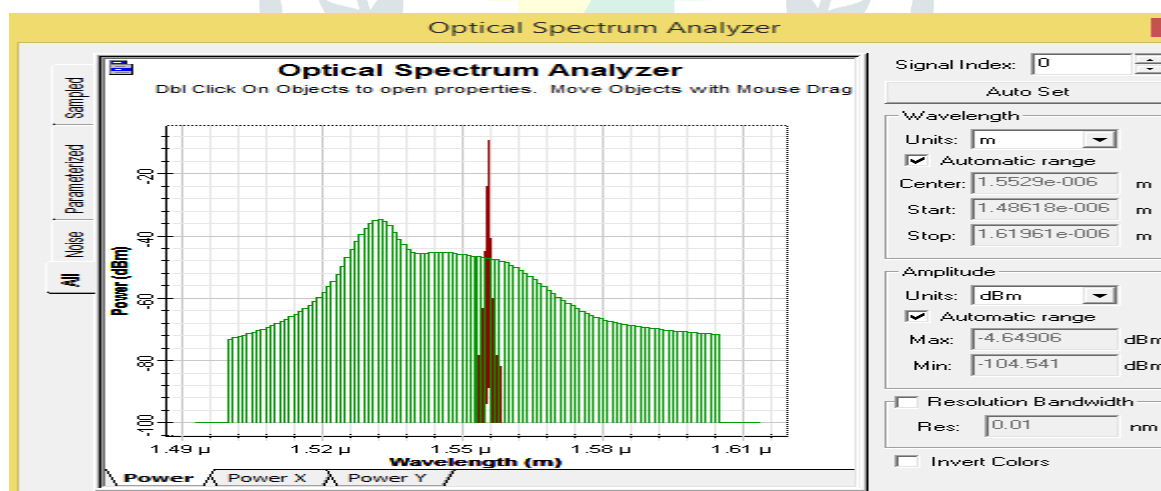

Figure 9: Received signal after FBG compensation using pre compensation technique

## Conclusion

We have analyzed the 3R regenerator using Fiber Bragg Grating at different fiber lengths. The optical communication point to point link establishment is dependent on bit rate, transmission link length and bit error rate. The development of all optical 3R regenerator with reamplification, reshaping and retiming as its features becomes essential. The simulated transmission system have been analyzed on the basis of different parameters. By simulating a model of communication system and using the most suitable settings of the system which include input power (dBm), fiber cable length (km), FBG Length (mm) and attenuation coefficient (dB/km) at cable section, four different parameters will be investigated which are output power (dbm), noise figure (dB), gain (dB) and Q Factor (dB) at receiver. We



will see the help of eye diagrams in subsequent graph. All the results are analyzed using OPTISYSTEM simulation at 10 Giga bits per second (Gb/s) transmission systems. From the simulation result, it can conclude that the optical fiber length is inversely proportional to the Q-Factor. The amplified transmission link compensated the losses in the network. Dispersion compensated link reduced the effect of distortion, hence further increasing the data rate of transmission. Clock recovery was implemented to reduce time jitter of the signal which lead to flexibility of link length and data rate.

## REFERENCES

- [1] M. Zhu, et al. "Availability-Aware Joint Task Scheduling for Real-Time Distributed Computing Applications over Optical Networks," DOI: 10.1109/ICC.2010.5502646, IEEEICC 2010, South Africa, May 2010.
- [2] Althi Bhavya Bindu et al. "Proposal and Need for All Optical 3R Regenerator" IEEE WiSPNET 2017 conference.
- [3] Banerjee A., Park Y., Clarke F., Song H., Yang S., Kramer G., Kim K., Mukherjee B., 'Wavelength-division-multiplexed passive optical network (WDM-PON) technologies for broadband access', Journal of optical networking, Vol. 4, No. 11, 2005.
- [4] C.F. lam, Passive Optical Networks Principles and Practice, Ch. 1, pp. 1- 17, 2007.
- [5] M. Sumetsky and B.J. Eggleton "Fiber Bragg gratings for dispersion compensation in optical communication systems" J. Opt. Fiber. Commun. Rep. 2, 256–278 (2005)© 2005 Springer Science+Business Media Inc. DOI: 10.1007/s10297-004-0026-9
- [6] Gurinder Singh et.al., "Investigations on order and width of RZ super Gaussian pulse in different WDM systems at 40 Gb/s using dispersion compensating fibers," Optik 125, pp. 42704273, 2014.

