

Optimization Analysis and Modification in Sprocket Structure

¹S. R. Ahire, ²Dr. Chitresh Nayak, ³N. J. Rathod

¹Student, ²Associate Professor, ³Assistant Professor

¹Department of Mechanical Engineering,

¹Oriental Institute of Science and Technology, Bhopal, India

Abstract: This work present the optimization analysis of transfer coal conveyor shaft and modification in sprocket structure. An investigation will be performed to determine the failure root cause and factors affecting on transfer coal conveyor shaft. Finite Element Analysis (FEA) will also perform to quantify the stress distribution in the shaft. Thus the strength of shaft is to be important parameter to be taken into account while designing. The 3D model is prepared by using CATIA pre-processing and post-processing is prepared by using Ansys workbench. The load and boundary condition were applied in Ansys as per shaft mounting on conveyor. This process helps in finding the optimized design for the shaft in which it has the best performance without any failure. Optimization of shaft was carried out by selecting better material for weight reduction and better strength. FEA also be carried out on optimized design of the shaft to check whether the optimized design is safe or not. FE Analysis has done using model and shaft deformation test carried out on Universal testing machine to validate analysis results.

Key Words - Shaft, CATIA software, ANSYS software, Universal testing machine, Optimization.

1. INTRODUCTION

A conveyor system is a common piece of mechanical handling equipment that moves material from one location to another. It is used in transportation of heavy or bulky materials. Conveyor systems are very popular in material handling and packaging industries because it allows quick and efficient transportation for wide variety of materials. Many factors are important in the accurate selection of a conveyor system. Now day's major breakdown in continuous running plant is too costly. The gearbox and motor was directly coupled to the shaft with the help of chain and sprocket therefore overall subject of project is the optimization analysis of drive shaft which is used in transfer coal conveyor.

2. REVIEW OF LITERATURE

The different work to be carried out on transfer coal conveyor system in recent years.

M.A. Alspaugh [1] works on "Latest Developments in Belt Conveyor Technology". This paper describes the application of conventional components in non-conventional applications for this requiring intermediate drives and horizontal curves have changed and expanded conveyor belt possibilities. S.H. Masood et. al. [2] works on "An investigation into design and manufacturing of mechanical conveyors systems for food processing". In this used the principles of design and concept of concurrent engineering for design of assembly and manufacturing. Investigation was done for several critical conveyor parts to check their strength criterion, functionality, material suitability, cost and ease of assembly in overall conveyor system. By using new materials the critical parts were modified and redesigned with new shape and geometry. Verification of the functionality of new conveyor parts and the improved design methods was done and were tested on a new test conveyor system designed, manufactured and assembled using the new improved parts. The new better technique is used for production and design of conveyor components for the reduction of materials, parts and costs. A. Goksenli et. al. [3] works on "Failure analysis of an elevator drive shaft". Paper describes failure occurred at the keyway of the shaft. After visual investigation of the fracture surface it is concluded that fracture occurred due to tensional bending fatigue. Fatigue crack has initiated at the keyway edge. Investigation was carried out to find reason of failure for this finite element method was used. It is concluded that fracture occurred because of manufacturing or design of keyway is incorrect. i.e. high notch effect occurs because of low radius of curvature at keyway corner. In conclusion by using FEM explain the effect of change in radius of curvature on stress distribution and in order to prevent similar failure which precautions have to be taken is clarified. Gys van Zyl et. al. [4] this paper describes that during service the shaft of a conveyor belt drive pulley was failed. An investigation was performed in order to determine the failure root cause and contribution factors. Investigation methods included optical and scanning electron microscope analysis, visual examination, chemical analysis of the material and mechanical tests. In order to quantify the stress distribution in the shaft a finite element analysis was also performed. It is concluded that due to fatigue the shaft was failed and cause of shaft failure is due to inappropriate refit of the shaft during routine use. Dima Nazzal et. Al. [5] works on "Survey of Research in Modeling Conveyor Based Automated Material Handling Systems in wafer fabs". This paper describes literature of models of conveyor systems in semiconductor fabs. A comprehensive overview of simulation-based models is provided. We also identify and discuss specific research problems and needs in the design and control of closed-loop conveyors. It is concluded that in order to understand the behavior of such systems and bridge the gap between theoretical research and industry problems a new analytical and simulation models of conveyor systems need to be developed. John Usher et. al. [6] this paper provides the details of analysis of the reliability and availability of two common designs of the line-shaft roller conveyor. The first is a standard design in which every roller is belted directly to a line shaft under the conveyor. In second design the only one top roller is belted to the line shaft and all other remaining rollers are belted to the one powered roller in a series arrangement. This design is done because of the upper belts are faster to replace than belts connected to the line shaft, so increasing system availability. However, the reliability of latter design is less in that the failure of a single belt may causes to multiple roller failures. C. Sekimoto [7] works on "Development of Concept Design CAD System". This paper discusses in order to shorten the product development time and improve the product quality, 3 dimensions at CAD/CAE system is essential. It is necessary to develop a system which utilizes the

concept design data at the early stage for the whole process of the product development. The purpose of this paper is to improve the product quality by the sufficient design study iteration at the early stage of design. A CAD system which can be used for the conception design and a proper CAD environment should be developed and another purpose.

3. ANALYSIS OF EXISTING SHAFT

A static analysis forecast the effect of steady loading condition on structure, while forgetting damping and inertia effects, such as those caused by time varying loads. A static analysis include steady inertia load such as gravity and rotational. Static analysis resolves the displacements, stresses, strains, and forces in structures or components caused by loads. That does not induce significant inertia and damping effects. For analysis of existing shaft firstly drawing with evaluated dimensions is made in CATIA. After this model imported in ANSYS. Forces and boundary condition applied to the model then meshing of shaft using hexahedral element is done and the result of the analysis shows stresses and deformation of existing shaft material. The result obtained in analysis shown below:

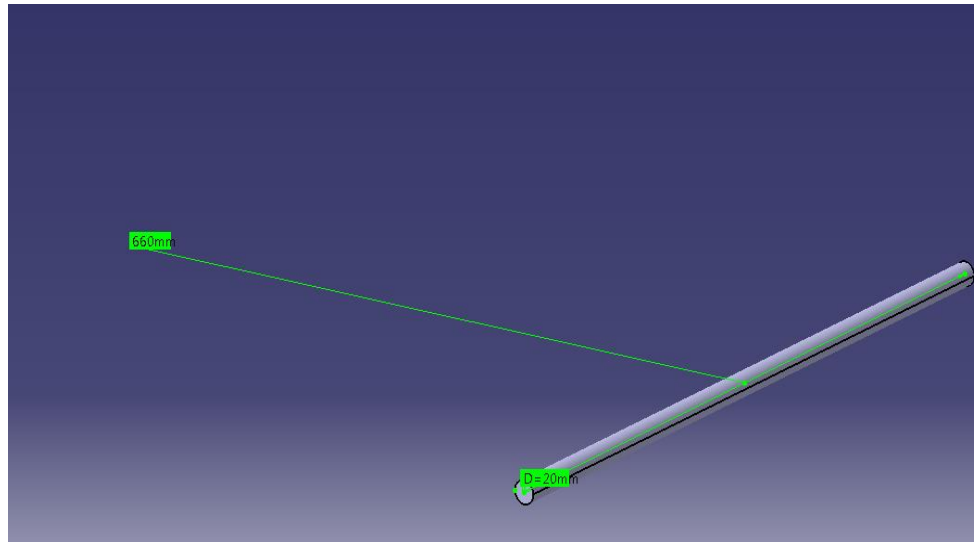

Fig. 1 CATIA model of shaft

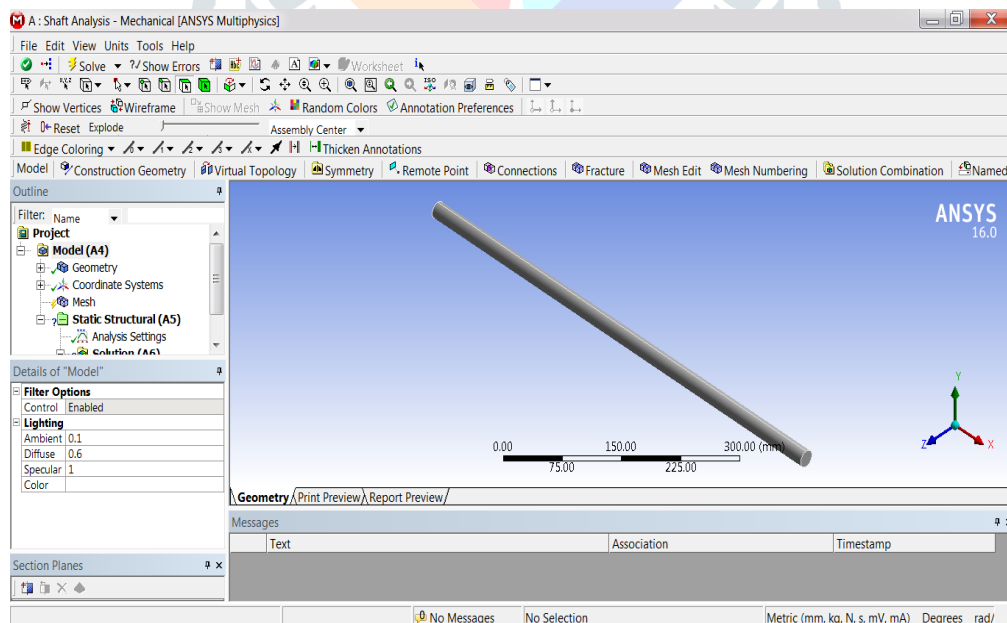

Fig. 2 Shaft model imported in ANSYS

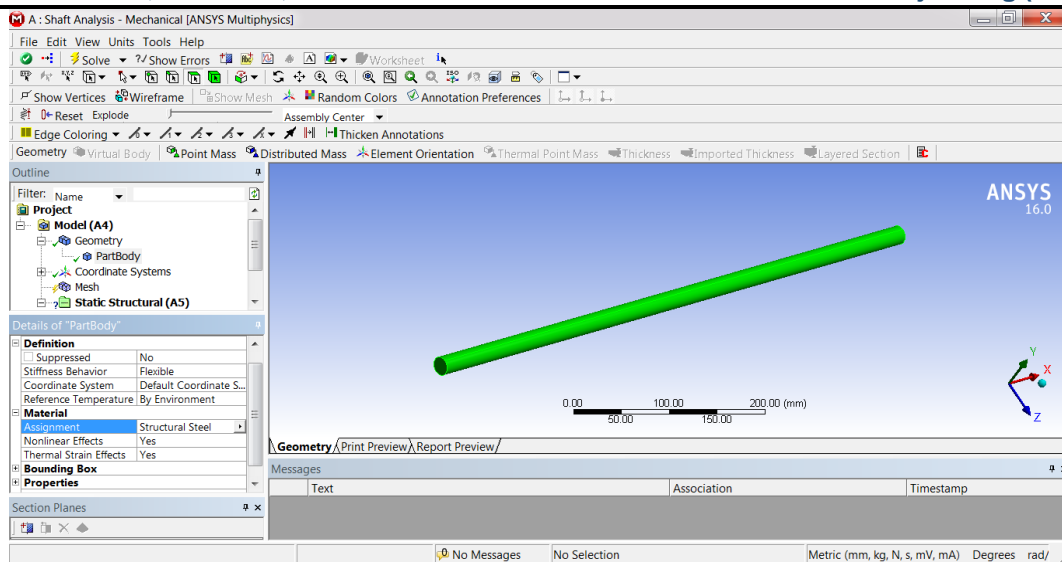

Fig.3 Shaft model material assignments

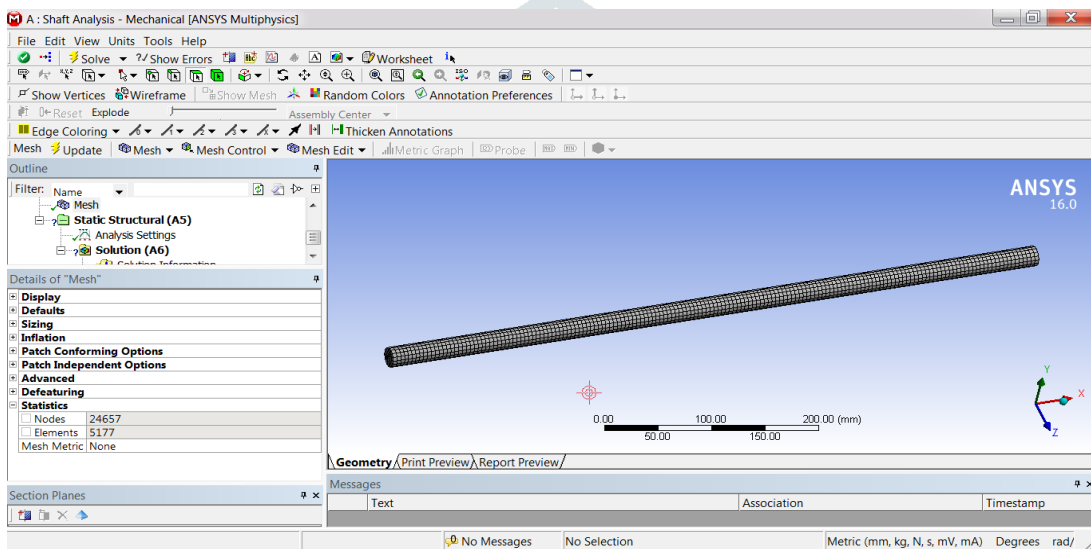

Fig.4 Meshing of the shaft using hexahedral elements

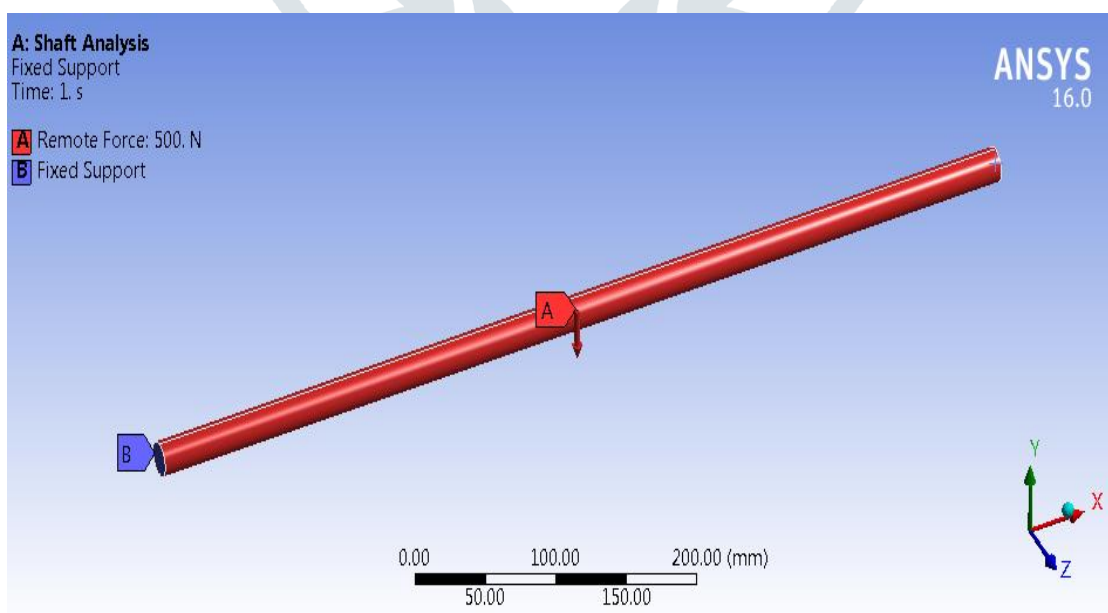

Fig.5 Boundary condition on shaft

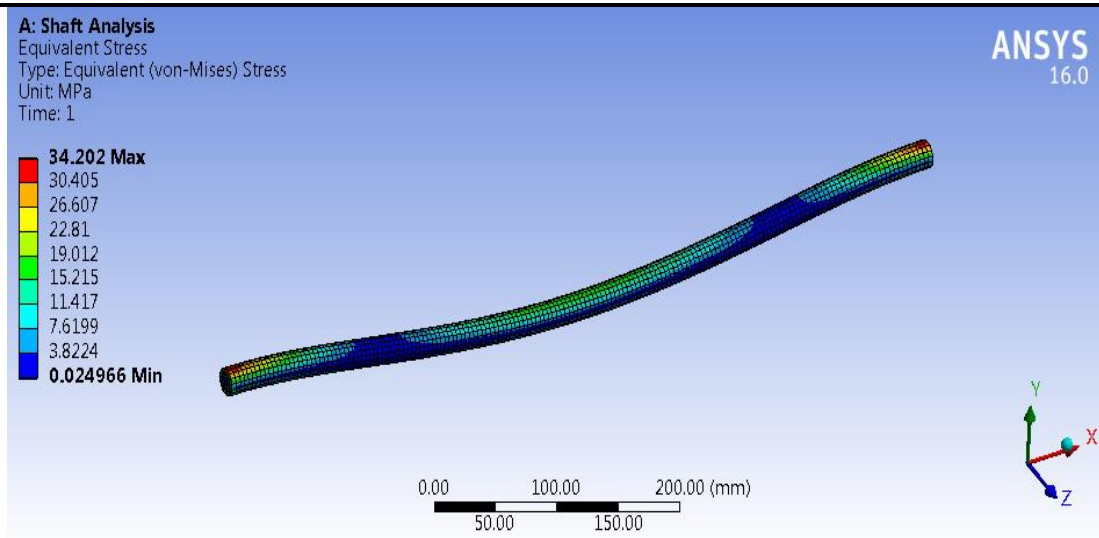

Fig.6 Von Misses Stresses in the shaft

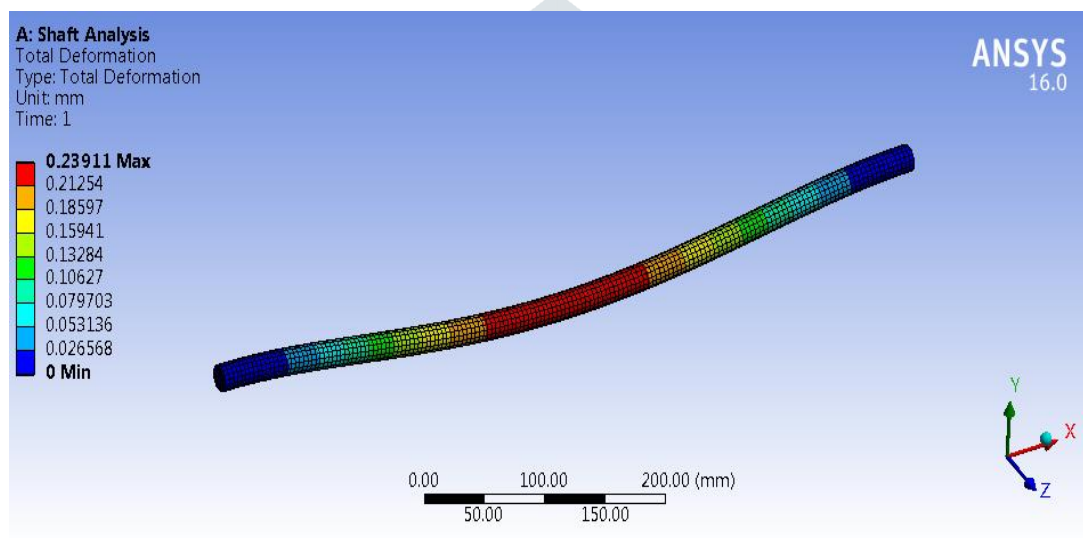

Fig.7 Deformation in shaft

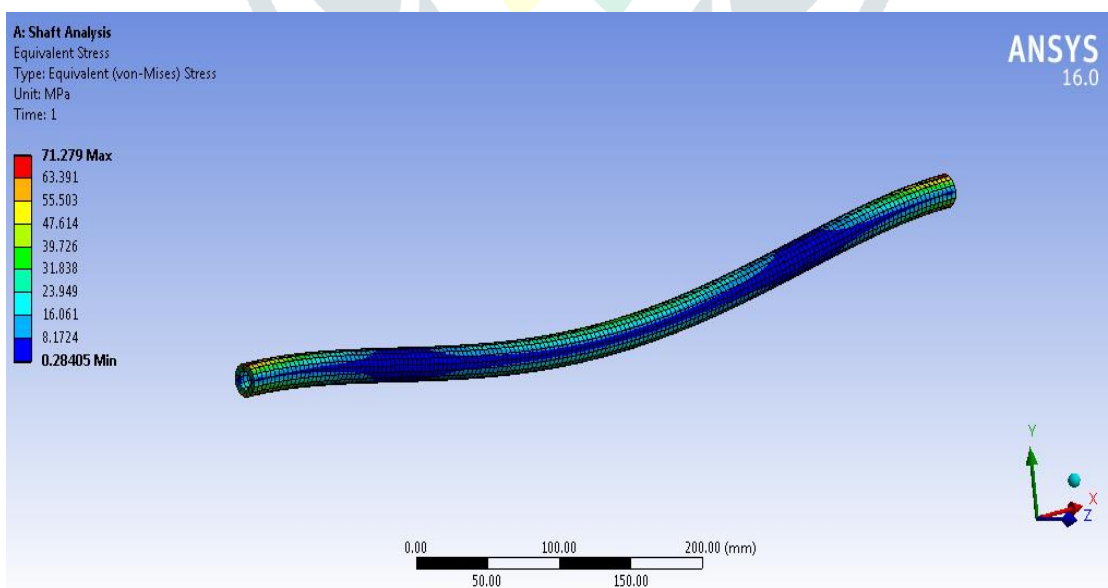

Fig.8 Von Misses Stresses in hollow shaft

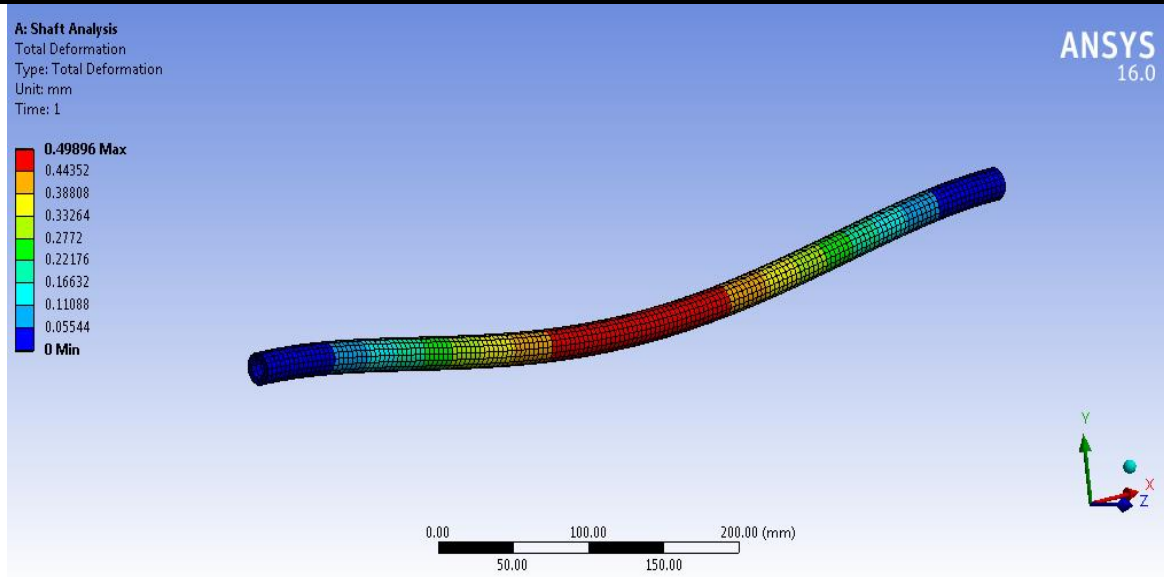

Fig.9 Deformation in hollow shaft

For solid shaft maximum deformation 0.23911 mm and von mises stress is 34.202 MPa and for hollow shaft maximum deformation 0.49896 mm and von mises stress is 71.279 MPa.

4. COMPOSIT MATERIAL ANALYSIS

A composite material is made by combining two or more materials, ones that have very different properties. The two materials work together to give the composite unique properties. Benefits of composite material:

- Light weight
- Non corrosive
- Non conductive
- Flexible
- Low maintenance
- Long life
- Design flexibility

Modulus of elasticity (E), Modulus of rigidity (G), Poisson Ratio (ν) these properties are considered for FEA of composite material. These properties used from engineering data manager.

4.1 ANALYSIS BASED ON DIFFERENT ORIENTATIONS ANGLES

4.1.1 90/0/90/0 ORIENTATIONS ANGLE

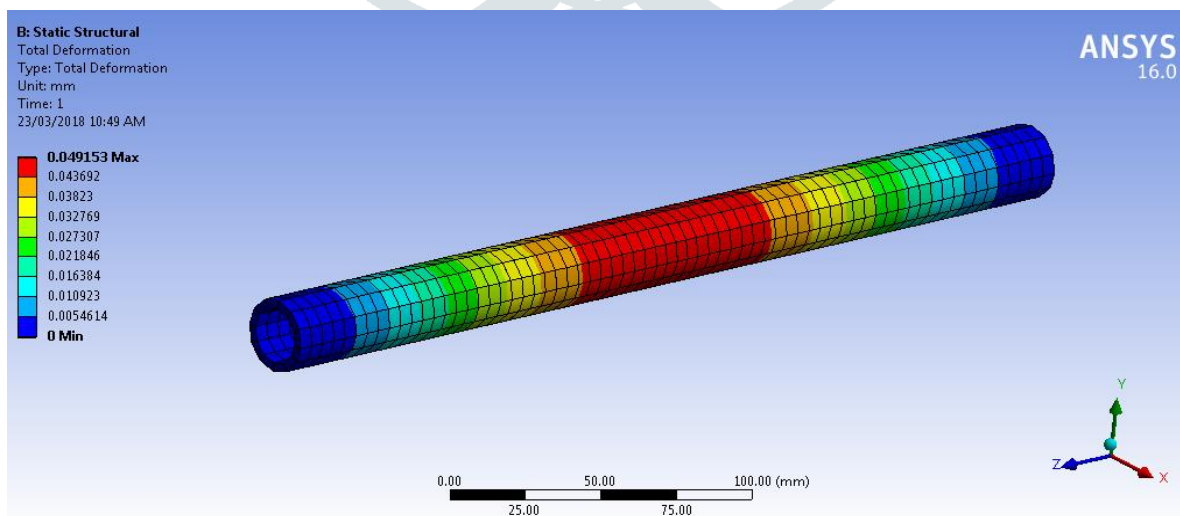

Fig.10 Deformation on shaft

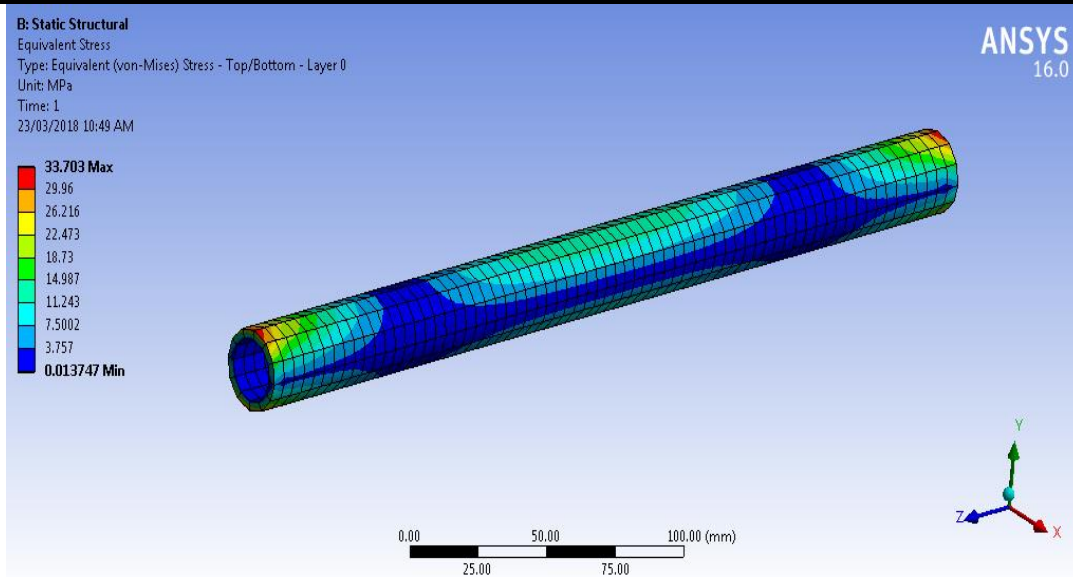

Fig.11. Stresses on shaft

Table. 1 Analysis results for different orientations angles

Orientations	Stress (MPa)	Deformation (mm)
90/90/90/90	44.937	0.065537
45/0/45/0	62.912	0.091752
90/0/90/0	33.703	0.049153
30/0/30/0	62.013	0.090442
60/0/60/0	56.171	0.081922
30/60/30/60	71.9	0.10486
45/90/45/90	49.431	0.072091
90/90/90/90	44.937	0.065537
45/0/45/0	62.912	0.091752

From above results it can be seen that the stresses in steel shaft is higher than composite shaft by considerable values. Also we can see that deformation is on higher side in composite layers. Layer orientation 90/0/90/0 gives better result hence considered for final case.

4.2 ANALYSIS BASED ON DIFFERENT COMPOSITE MATERIAL

Materials selected for further analysis:

- Carbon Epoxy Woven
- E-Glass Epoxy
- Resin Epoxy

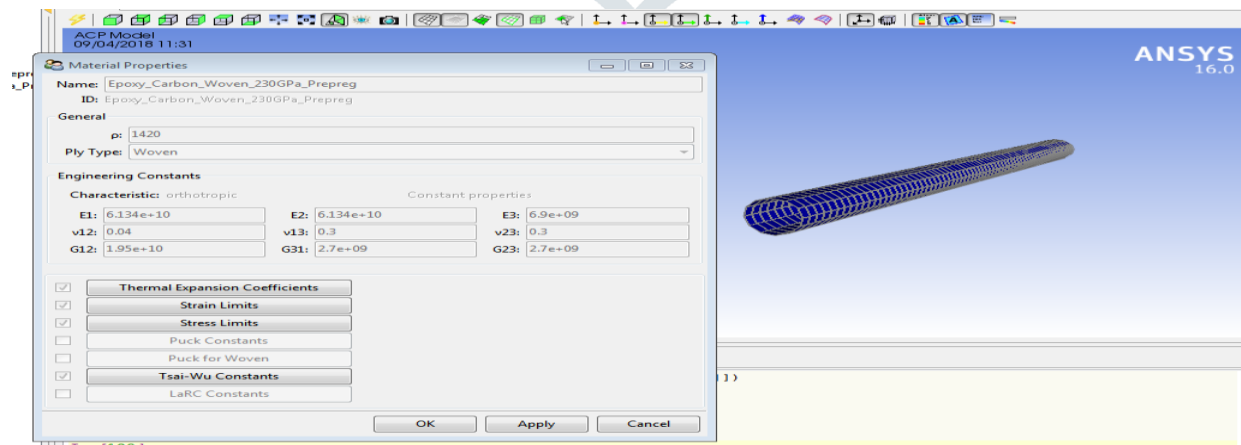

Fig.12 Application of Carbon Epoxy Woven material

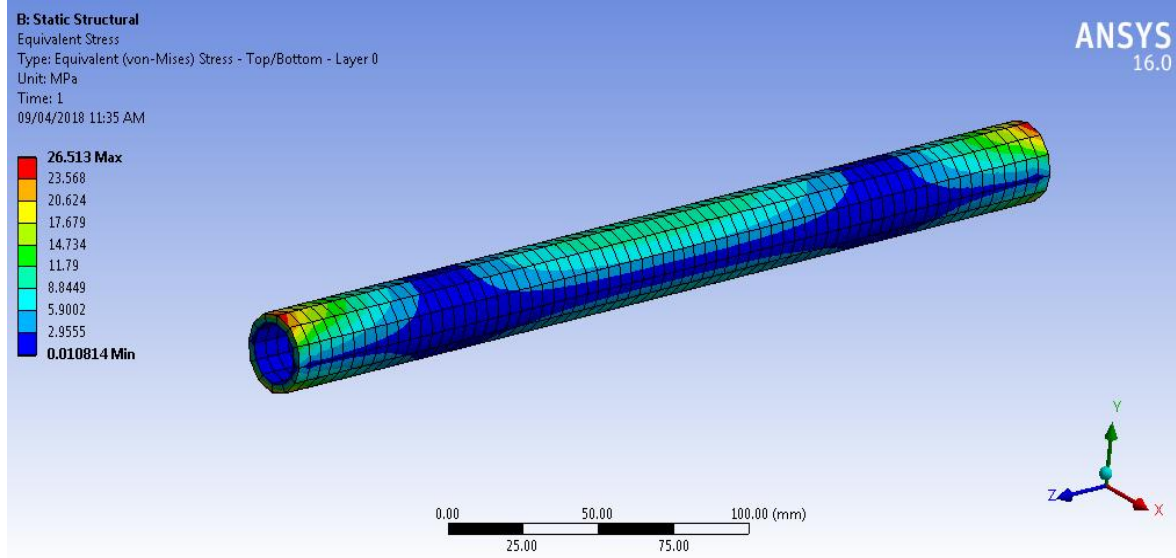

Fig.13 stresses using Carbon Epoxy Woven Material

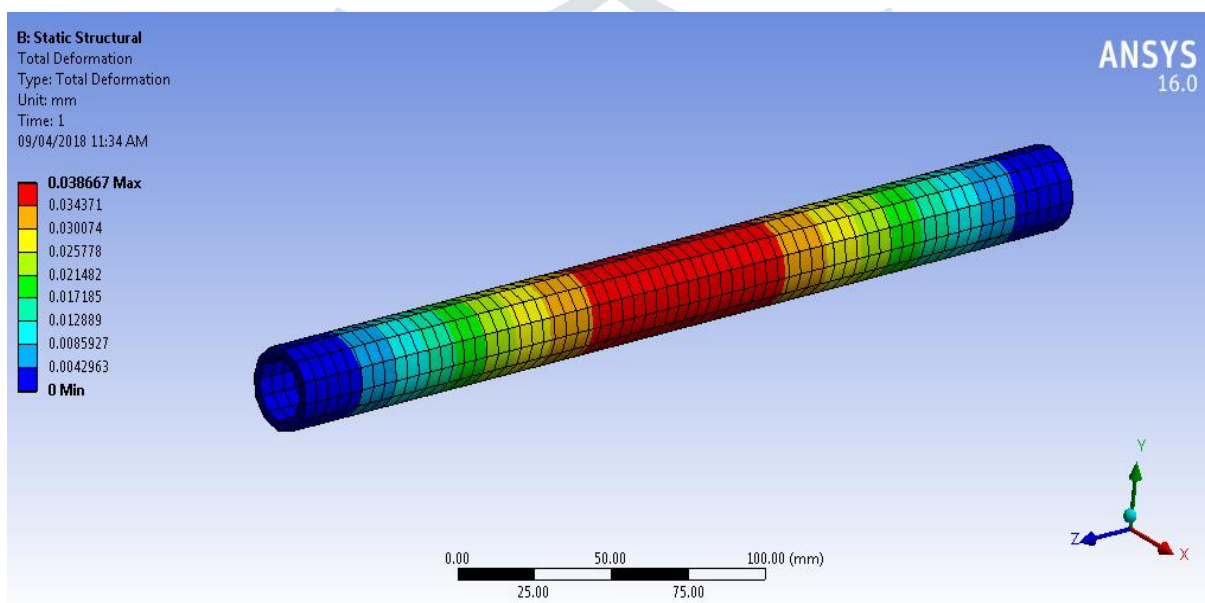

Fig.14 Deformation using Carbon Epoxy Woven Material

Table.2 Analysis results for different materials

Sr. No.	Orientations	Material	Stress (MPa)	Deformation (mm)
1	90/0/90/0	Carbon Epoxy UD	33.703	0.049153
2	90/0/90/0	Carbon Epoxy Woven	26.513	0.038667
3	90/0/90/0	E-Glass Epoxy	58.418	0.085199
4	90/0/90/0	Resin Epoxy	51.678	0.075368

Carbon Epoxy with Woven (90/0/90/0) gives better results among selected materials.

5. EXPERIMENTAL TESTING

A universal testing machine (UTM), also known as a universal tester, is used to test the tensile strength and compressive strength of materials. Experimentation is done for analyzing the shaft's deformation. As FOS is high for shaft so stresses are of secondary importance.

5.1 MACHINE SPECIFICATION UTM

Table.3 UTM Specifications

Max Load Capacity	100KN
Load Accuracy	Within +/-1%
Test Space Tensile Compression	680 mm 620 mm
Piston Stroke	250 mm
Dimensions	700*610*2200 mm
Power Supply	Three-Phase, 240V-50HZ



Fig.15 Testing of Shaft on UTM

5.2 EXPERIMENTAL TEST RESULTS FOR CARBON EPOXY WOVEN

Testing of conveyor shaft having Carbon Epoxy Woven material shown in table below:

Table. 4Test Result on UTM

Material	Deformation, mm (Experimental)			
	Trial 1	Trial 2	Trial 3	Avg.
Carbon Epoxy Woven At (90/0/90/0) orientation	0.041	0.039	0.041	0.040

6. CONCLUSIONS

1. Orientation optimization study is done and final Orientations selected are 90/0/90/0.
2. Material optimization is done and carbon epoxy woven material is suggested so strength of shaft is improved and weight is reduced.
3. Stresses and deformation are less for optimized selection than existing shaft.
4. FEA and Experimental deformation results for optimized shaft shows only 4.17% error.

7. REFERENCES

- [1] M.A. Alspaugh, "Latest Developments in Belt Conveyor Technology" MINExpo 2004, Las Vegas, NV, USA. September 27, 2004.
- [2] S.H. Masood, B. Abbas, E. Shayan, A. Kara "An investigation into design and manufacturing of mechanical conveyors Systems for food processing", Springer-Verlag London Limited 2004.
- [3] A. Goksenli, I.B. Eryurek, "Failure analysis of an elevator drive shaft" at science direct journal - Engineering Failure Analysis 16 (2009) 1011–1019.
- [4] Gys van Zyl, Abdulmohsin Al-Sahli, "Failure analysis of conveyor pulley shaft" at science direct journal - Case Studies in Engineering Failure Analysis 1 (2013) 144–155.
- [5] Dima Nazzal, Ahmed El-Nashar "Survey of Research in Modeling Conveyor-Based Automated Material Handling Systems In wafer fabs" Proceedings of the 2007 Winter Simulation Conference.
- [6] John Usher, John R, G. Don Taylor "Availability modeling of powered roller conveyors".
- [7] C.Sekimoto "Development of Concept Design CAD System", Energy and Mechanical Research Laboratories, Research and Development Center, Toshiba Corporation.

