

SIMULATION AND ANALYSIS FOR POWER MANAGEMENT OF GRID-CONNECTED PHOTO VOLTAIC AND FUELL CELL BASE HYBRID POWER SYSTEM

Prof. Sohan Prajapati¹, Gunvant A. Patel², Harshadkumar D. Patel³

¹Assistant Professor, Electrical Department, GEC-Patan, Patan, Gujarat, India

²Research Scholar, SRK University, Bhopal, Madhya Pradesh, India

³Research Scholar, HRED, IIT Roorkee, India.

ABSTRACT: *The Hybrid system refers to those applications in which multiple energy conversion devices are used together to supply an energy requirements. The hybrid system can either be connected to the main grid or work autonomously with respect to the grid-connected mode. In the grid-connected mode, the hybrid source is connected to the main grid at the point of common coupling (PCC) to deliver power to the load. When load demand changes, the power supplied by the main grid and hybrid system must be properly changed. The power delivered from the main grid and PV (Photo Voltaic) array as well as FC (Fuel Cell) must be coordinated to meet load demand. The hybrid source has two control modes: 1) unit-power control (UPC) mode and feeder-flow control (FFC) mode. In the UPC mode, variations of load demand are compensated by the main grid because the hybrid source output is regulated to reference power. Therefore, the reference value of the hybrid source output must be determined. In the FFC mode, the feeder flow is regulated to a constant, the extra load demand is picked up by the hybrid source, and, hence, the feeder reference power must be known. This paper presents a method to operate a grid connected hybrid system. The hybrid system composed of a Photovoltaic (PV) array and a Fuel cell (FC) is considered. This output can be obtained for two modes of operation using perturbation and observation algorithm. The effectiveness of the proposed method was tested on grid connected PV-FC system using Simulink in MATLAB.*

INTRODUCTION

Renewable energy is currently widely used. One of these resources is solar energy. The photovoltaic (PV) array normally uses a maximum power point tracking (MPPT) technique to continuously deliver the highest power to the load when there are variations in irradiation and temperature. The disadvantage of PV energy is that the PV output power depends on weather conditions and cell temperature, making it an uncontrollable source. Furthermore, it is not available during the night. In order to overcome these inherent drawbacks, alternative sources, such as PEMFC, should be installed in the hybrid system. By changing the FC output power, the hybrid source output becomes controllable. However, PEMFC, in its turn, works only at a high efficiency within a

specific power range $(P_{FC}^{low} \div P_{FC}^{up})$. The hybrid system can either be connected to the main grid or work autonomously with respect to the grid-connected mode or islanded mode, respectively. In the grid-connected mode, the hybrid source is connected to the main grid at the point of common coupling (PCC) to deliver power to the load. When load demand changes, the power supplied by the main grid and hybrid system must be properly changed. The power delivered from the main grid and PV array as well as PEMFC must be coordinated to meet load demand. The hybrid source has two control modes: 1) unit-power control (UPC) mode and feeder-flow control (FFC) mode. In the UPC mode, variations of load demand are compensated by the main grid because the hybrid source output is regulated to reference power.

Objectives

- It has been well-proven that a photovoltaic power source should be integrated with other power sources, whether used in either a stand-alone or grid-connected system, as it cannot produce power during night hours or under cloudy weather conditions. The system under study in this thesis is a stand-alone hydrogen PVFC power system, which is constituted of a photovoltaic generator, an alkaline water electrolyser, a proton-exchange membrane fuel cell stack, battery as a secondary back-up unit and a tank used for hydrogen storage. This system is intended to be a future competitor of hybrid PV/Diesel systems, especially from an environmental point of view.
- Proper data collecting and/or data synthesizing that describes the system operation and the load profile
- Visualizing and analyzing the system dynamic behavior using power flow trace over middle-term duration, such as one week or one day.
- Creating an accurate simulation system model to predict the real performance of the hydrogen PVFC power system
- Making the parameters of the system as configurable as possible in order the models to be used for a larger variety in applications (mostly different sized applications or components with different datasheets).

OVERVIEW OF PV-FC BASED HYBRID SYSTEM

The utilization of intermittent natural energy resources such as solar, wind and hydro energy requires some form of energy storage. The concept of utilizing hydrogen as a substance for storage of energy is shown in Figure-1. In this paper, a hybrid system based on hydrogen technology is considered. It needs hydrogen producing unit (electrolyser), a unit for hydrogen storage (tank), and a hydrogen utilizing unit (PEM fuel cell stack). However, the system based on intermittent energy sources and is likely to experience large minutely, hourly and daily fluctuations in energy input.

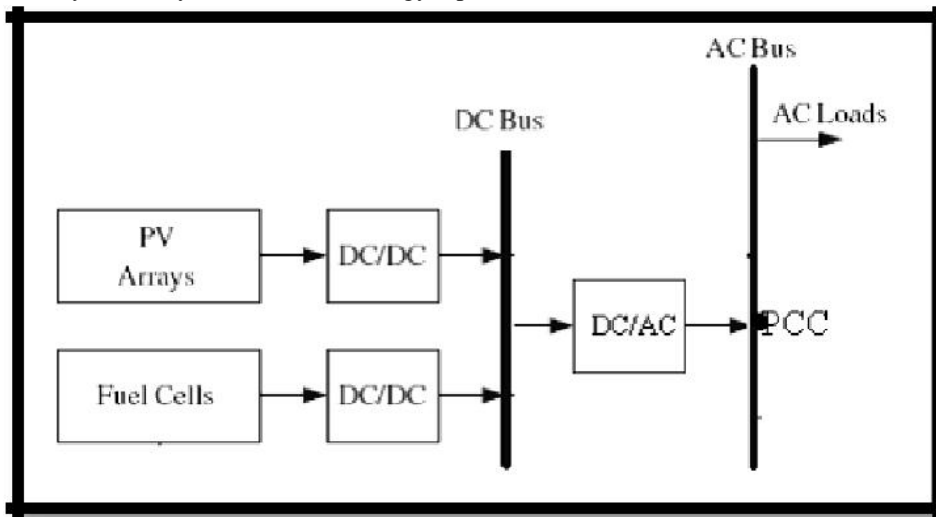

Fig-1-Grid connected PV-FC Hybrid system

A PV system consists of a number of interconnected components designed to accomplish a desired task, which may be to feed electricity into the main distribution grid, to pump water from a well, to power a small calculator or one of many more possible uses of solar-generated electricity. The design of the system depends on the task it must perform and the location and other site conditions under which it must operate. This section will consider the components of a PV system, variations in design according to the purpose of the system, system sizing and aspects of system operation and maintenance. There are two main system configurations – stand-alone and grid-connected. As its name implies, the stand-alone PV system operates independently of any other power supply and it usually supplies electricity to a dedicated load or loads. It may include a storage facility (e.g. battery bank) to allow electricity to be provided during the night or at times of poor sunlight levels. Stand-alone systems are also often referred to as autonomous systems since their operation is independent of other power sources. By contrast, the grid-connected PV system operates in parallel with the conventional electricity distribution system. It can be used to feed electricity into the grid distribution system or to power loads which can also be fed from the grid. It is also possible to add one or more alternative power supplies (e.g. diesel generator, wind turbine) to the system to meet some of the load requirements. These systems are then known as „hybrid“ systems. Hybrid systems can be used in both stand-alone and grid-connected applications but are more common in the former because, provided the power supplies have been chosen to be complementary, they allow reduction of the storage requirement without increased loss of load probability. Figures below illustrate the schematic diagrams of the three main system types.

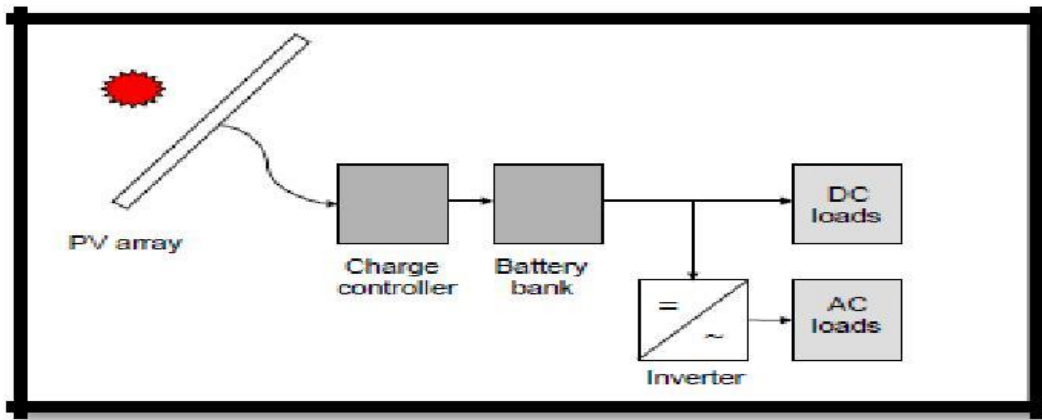

Fig-2 Schematic diagram of a stand-alone photovoltaic system

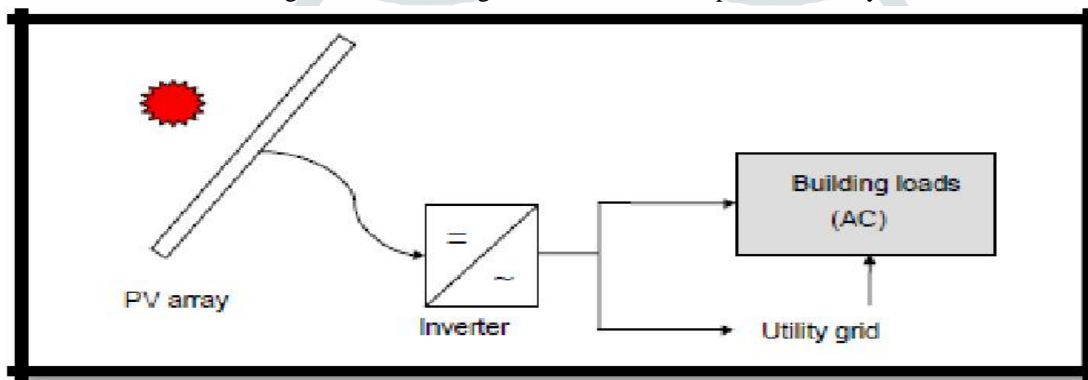

Fig-3 Schematic diagram of grid-connected photovoltaic system

FUEL CELL

A fuel cell consists of a negatively charged electrode (anode), a positively charged electrode (cathode) and an electrolyte membrane. Hydrogen is oxidized at the anode and oxygen is reduced at the cathode. Protons are transported from the anode to the cathode through the electrolyte membrane, and the electrons are carried to the cathode over the external circuit. In nature, molecules cannot stay in an ionic state; therefore they immediately recombine with other molecules in order to return to the neutral state. Hydrogen protons in fuel cells stay in the ionic state by travelling from molecule to molecule through the use of special materials. The protons travel through a polymer membrane made of per sulfonic acid groups with a Teflon backbone. The electrons are attracted to conductive materials and travel to the load when needed. On the cathode, oxygen reacts with protons and electrons, forming water and producing heat. Both the anode and cathode contain a catalyst to speed up the electrochemical processes, as shown in figure-4.

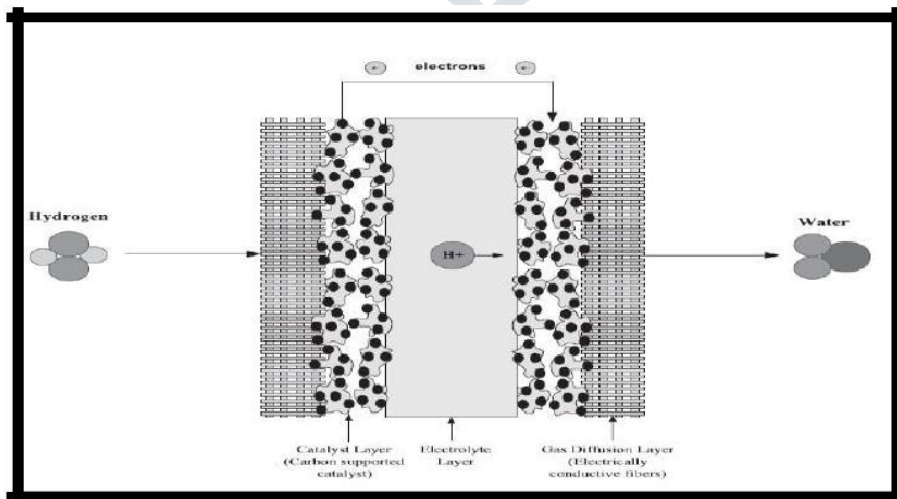

Fig 4-A single PEM fuel cell configuration

POWER MANAGEMENT

Power management is a feature of some electrical appliances, especially copiers, computers and computer peripherals such as monitors and printers, that turns off the power or switches the system to a low-power state when inactive. In computing this is known as PC power management and is built around a standard called ACPI. This supersedes APM. All recent (consumer) computers have ACPI support.

Motivation:

PC power management for computer systems is desired for many reasons, particularly:

- Reduce overall energy consumption
- Prolong battery life for portable and embedded systems
- Reduce cooling requirements
- Reduce noise.
- Reduce operating costs for energy and cooling. Lower power consumption also means lower heat dissipation, which increases system stability, and less energy use, which saves money and reduces the impact on the environment.

SYSTEM DESCRIPTION

The system consists of a PV-FC hybrid source with the main grid connecting to loads at the PCC as shown in Fig.5. The photovoltaic the PEMFC are modeled as nonlinear voltage sources. These sources are connected to dc-dc converters which are coupled at the dc side of a dc/ac inverter. The dc/dc connected to the PV array works as an MPPT controller. Many MPPT algorithms have been proposed in the literature, such as incremental conductance (INC), constant voltage (CV), and perturbation and observation (P&O). The P&O method has been widely used because of its simple feedback structure and fewer measured parameters. The P&O algorithm with power feedback control is shown in Fig. 6. As PV voltage and current are determined, the power is calculated. At the maximum power point, the derivative (dP/dV) is equal to zero.

PV Array Model

$$I_{sc}(T) = I_{scs} [1 + \Delta I_{sc}(T - T_s)] \tag{3}$$

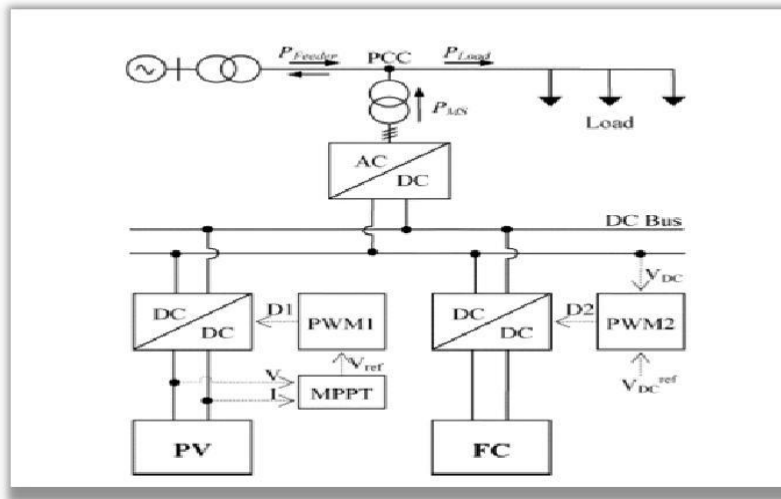

Fig 5-PV-FC base grid connected system

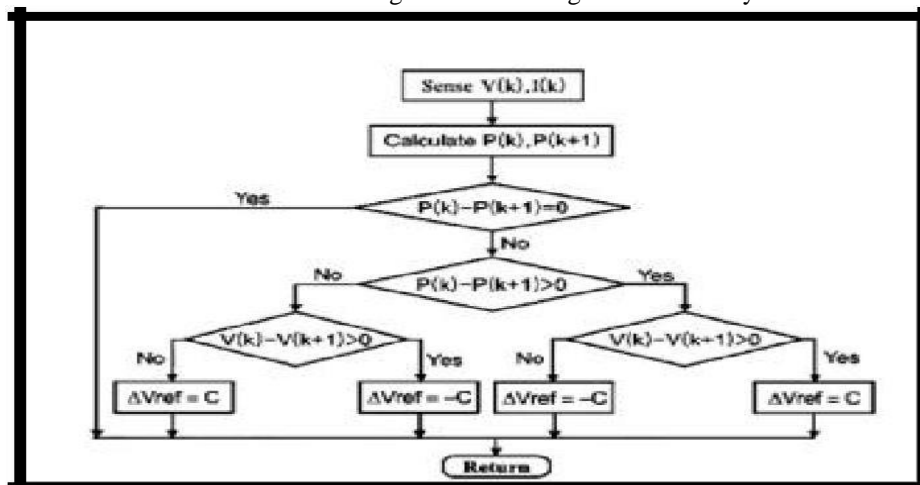

Fig 6-P & O algorithm

CONTROL OF THE HYBRID SYSTEM

The control modes in the micro grid include unit power control, feeder flow control, and mixed control mode. The two control modes were first proposed by Lasseter [12]. In the UPC mode, the DGs (the hybrid source in this system) regulate the voltage magnitude at the connection point and the power that source is injecting. In this mode if a load increases anywhere in the micro grid, the extra power comes from the grid, since the hybrid source regulates to a constant power. In the FFC mode, the DGs regulate the voltage magnitude at the connection point and the power that is flowing in the feeder at connection point P_{feeder} . With this control mode, extra load demands are picked up by the DGs, which maintain a constant load from the utility viewpoint. In the mixed control mode, the same DG could control either its output power or the feeder flow power. In other words, the mixed control mode is a coordination of the UPC mode and the FFC mode. Both of these concepts were considered in [13]–[16]. In this thesis, a coordination of the UPC mode and the FFC mode was investigated to determine when each of the two control modes was applied and to determine a reference value for each mode. Moreover, in the hybrid system, the PV and PEMFC sources have their constraints. Therefore, the reference power must be set at an appropriate value so that the constraints of these sources are satisfied. The proposed operation strategy presented in the next section is also based on the minimization of mode change. This proposed operating strategy will be able to improve performance of the system's operation and enhance system stability.

A 30 KW panel is considered as consisting of 24,080 solar cells arranged in 344X70 combinations. The solar array consists of number of panels connected in series-parallel configuration and a panel consists of number of cells. The power characteristics of the solar cell are formulated using its equivalent circuit. The equivalent circuit of the cell is presented as a current source in parallel with diode and a parallel resistance with a series resistance [6].

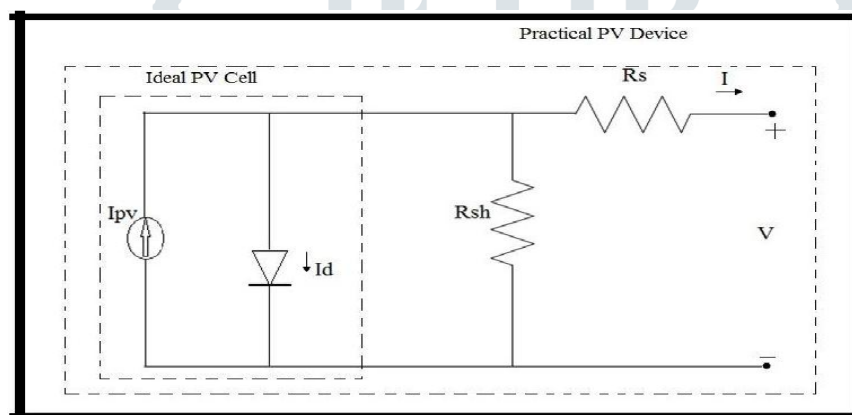

Fig 7: Equivalent circuit of a practical PV device [6]

SIMULATION & RESULTS OF GRID CONNECTED HYBRID POWER SYSTEM

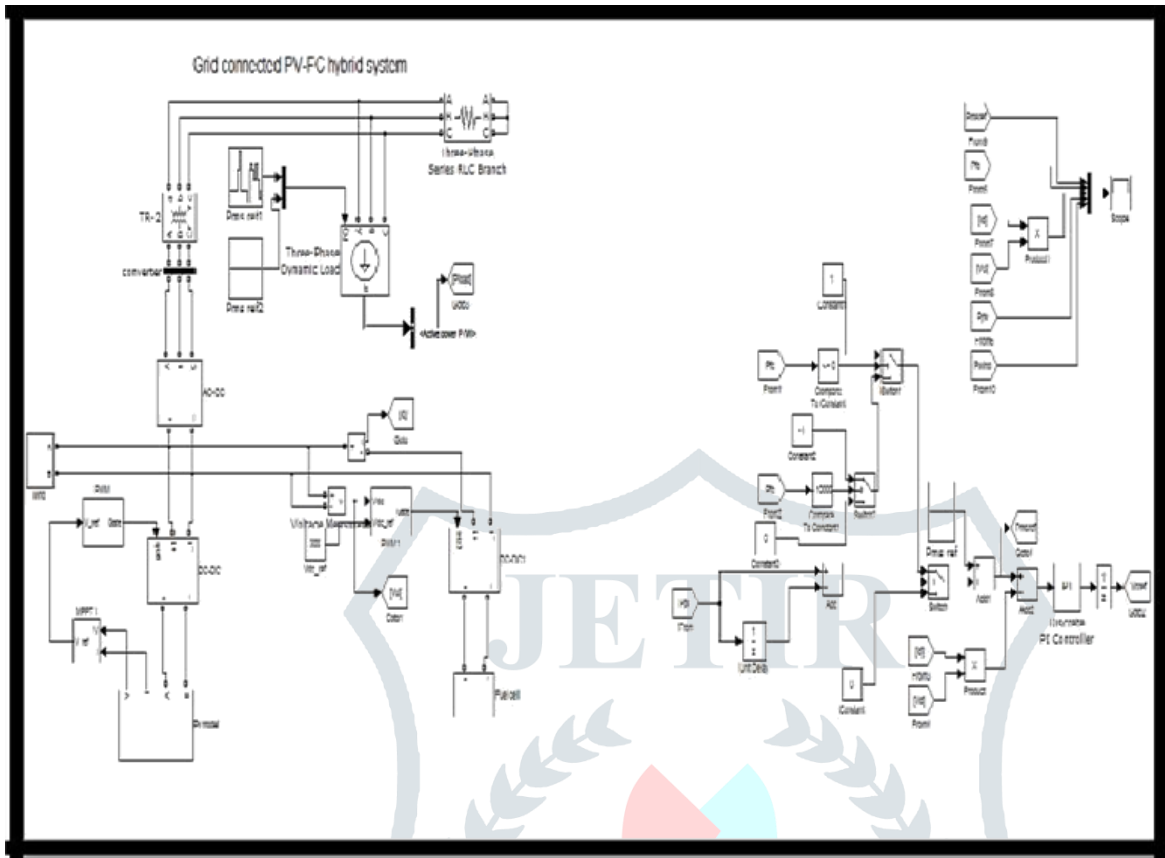

Fig 8-Grid Connected Hybrid PV-FC System

Simulation Results in the Case without Hysteresis and simulation was carried out by using the system model shown in Fig. below to verify the operating strategies.

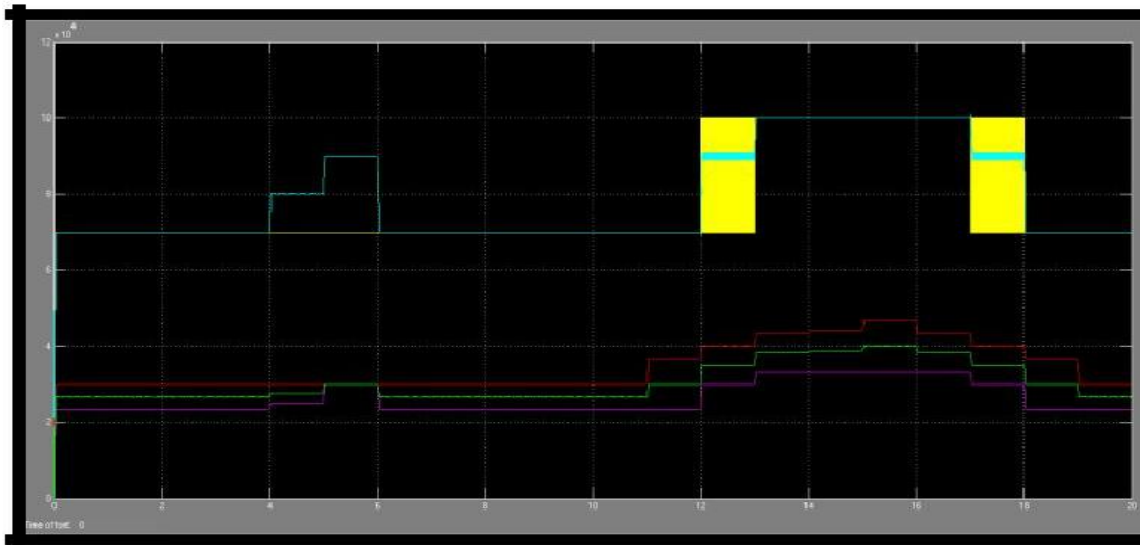

Fig.9- Simulation result without hysteresis. (a) Operating strategy of the hybrid source

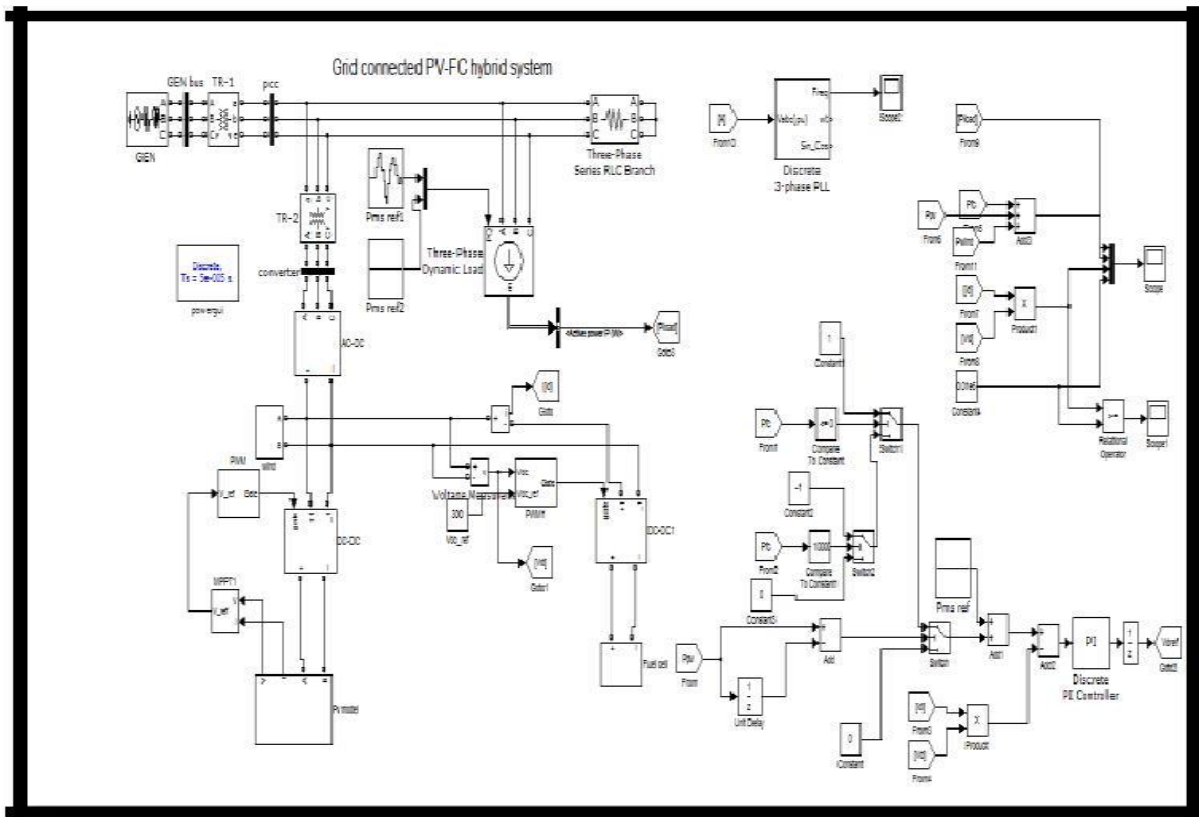

Fig 10- Grid connected operating strategy of the whole system

Improving Operation Performance by Using Hysteresis Fig.9 shows the simulation results when hysteresis was included with the control scheme shown in Fig. 10. From 12 s to 13 s and from 17 s to 18 s, the variations of FC output and feeder flow are eliminated and, thus, the system works more stably compared to a case without hysteresis.

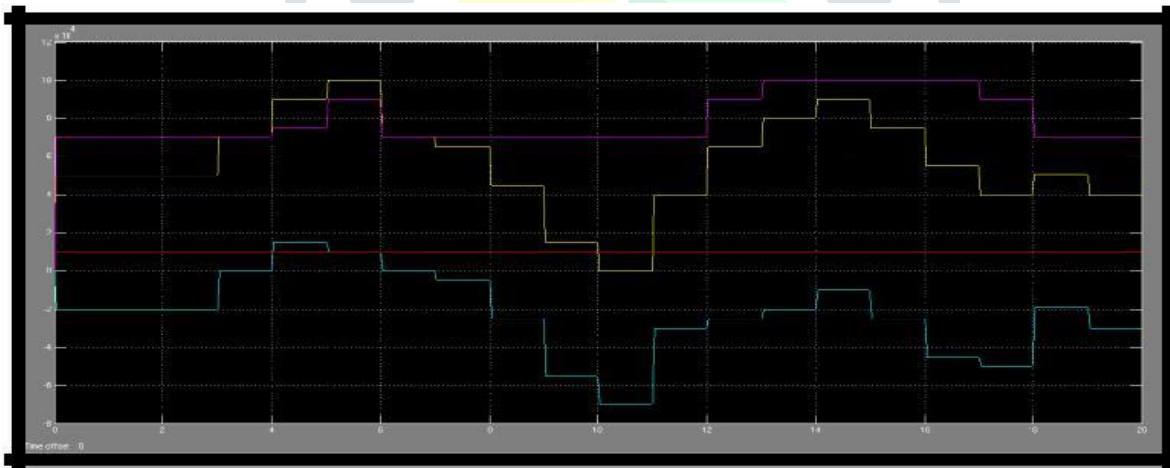

Fig 11-Simulation result without hysteresis (b) Operating strategy of the whole system

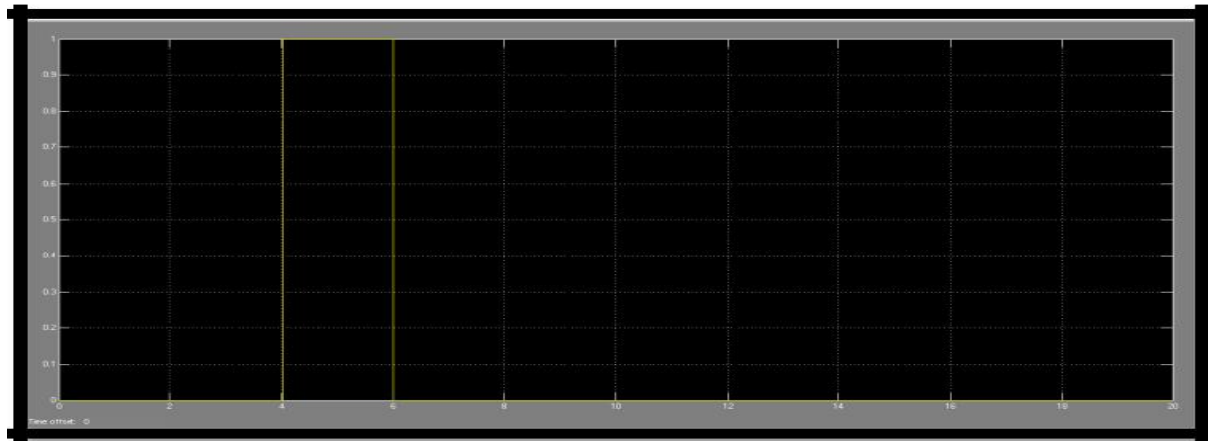

Fig 12 Simulation result without hysteresis (c) Change of operating modes

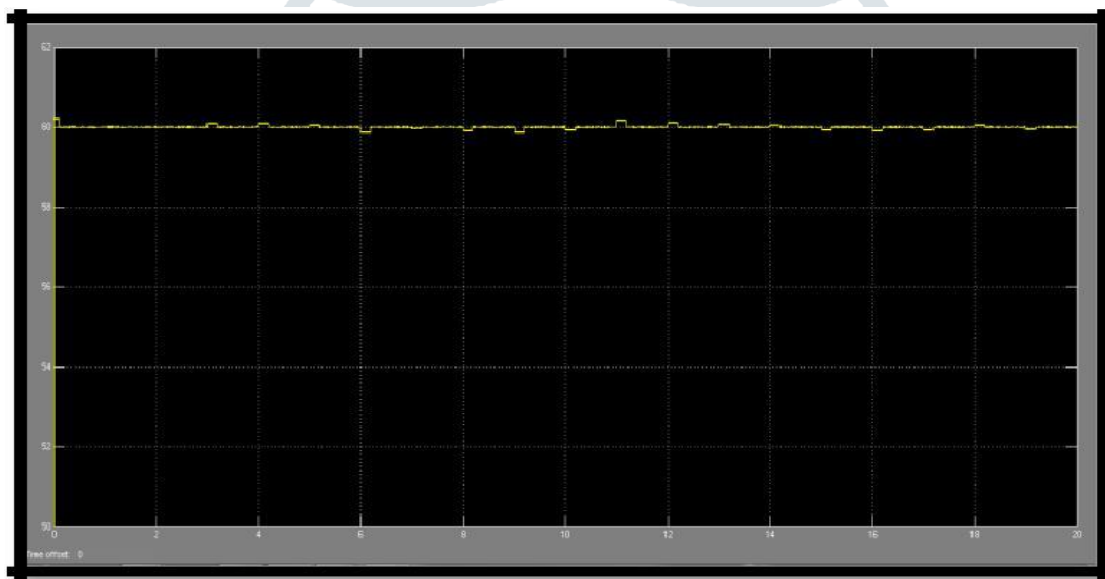

Fig.13 improving operation performance by using hysteresis:- (d) Frequency variations occur in the system

CONCLUSION

From the detail analysis of Photovoltaic system and Fuel Cell based hybrid system we can say that continuous power generation is obtain for customer and pubic. The hybrid connection of Solar PV system and FC system is easy and simple to design, operate. There is battery storage is also available for this kind of PV-FC base Hybrid system. This thesis has presented an available method to operate a hybrid grid-connected system. The hybrid system, composed of a PV array and PEMFC, was considered. The operating strategy of the system is based on the UPC mode and FFC mode. The purposes of the proposed operating strategy presented in this paper are to determine the control mode, to minimize the number of mode changes, to operate PV at the maximum power point, and to operate the FC output in its high-efficiency performance band. The change of the operating mode depends on the current load demand, the PV output, and the constraints of PEMFC and feeder power. With the proposed operating algorithm, the system works flexibly, exploiting maximum solar energy; PEMFC works within a high-efficiency band and, hence, improves the performance of the system's operation.

REFERENCES

- [1] Loc Nguyen Khanh, Student Member, IEEE, Jae-Jin Seo, Yun-Seong Kim, and Dong-Jun Won, Member, IEEE, "Power-Management Strategies for a Grid-Connected PV-FC Hybrid System", and IEEE TRANSACTIONS ON POWER DELIVERY, VOL. 25, and NO. 3, JULY 2010.
- [2] Dr. K. S. Srikanth, T. Krishna Mohan, Dr. L. V. Narasimha Rao, V. Ramesh, K. Naresh, " A Novel Grid-Connected PV-FC Hybrid System for Power-Management", Electrical & Electronics Engineering,

- KL University, International Journal of Research in Advent Technology, Vol.2, No.4, April 2014 E-ISSN: 2321-9637.
- [3] Chandan Kumar Tiwary , Dr. Amita Mohar, “PV-FC Hybrid System and Its Power Management Strategies in a Grid”, International Journal of Advanced Research in Electrical, Electronics and Instrumentation Engineering (An ISO 3297: 2007 Certified Organization) Vol. 3, Issue 10, October 2014.
- [4] N.Chaitanya Kumar Reddy, R.Maheswar Reddy, P.Malleswar Reddy, “ Power-Management Strategies for a Grid-Connected PV-FC Hybrid System”, International Journal Of Scientific Research And Education ,Volume-2,Issue,11,Pages-2228-2238,November-2014, ISSN (e): 2321-7545.
- [5] Pavani Yadav Gonti, Dr.S.Siva Prasad, “Power Management Strategy In Hybrid PV-FC And Wind-Power Generation Systems By Using Multi Input Single-Control (MISC) Battery”, International Journal of Research in Computer and Communication Technology, Vol 3, Issue 10, October – 2014, ISSN (Online) 2278-5841.
- [6] P.abid hussain, A.suresh kumar, “Power-Management Topologies for PV-FC Hybrid Grid Connected System”, International journal of scientific engineering and technology research, ISSN 2319-8885 Vol.03, Issue.22 September-2014.
- [7] P.harika, P.vishnu vardhan, sk.jan bhasha, “Grid-Connected Pv-Fc Hybrid System Power Control Using MPPT And Boost Converter”, Int. Journal of Engineering Research and Applications www.ijera.com ISSN: 2248-9622, Vol. 4, Issue 9(Version 2), September 2014.
- [8] Philippe POGGI, Christophe DARRAS, Marc MUSELLI, Guillaume PIGELET, “The PV-Hydrogen MYRTE platform - PV output power fluctuations smoothing”, Science Direct, Energy Procedia 57 (2014) 607 – 616, 2013 ISES Solar World Congress.
- [9] Atul Kumar Dewangan, “Modelling and Simulation of Photovoltaic Full Cell Hybrid System”, International Journal of Engineering Research & Technology (IJERT), ISSN: 2278-0181 Vol. 3 Issue 2, February – 2014.
- [10] Ampatzis Michail, “Modelling and Simulation of an autonomous Photovoltaic/Fuel Cell Hybrid System”, Graduation Thesis, Technical University of Crete Department of Electronics.

