

# Framework to support Product Lifecycle Management Implementation in Manufacturing Enterprises

Gururaja Sharma T<sup>a</sup>, Rajashekar Patil<sup>b</sup>

<sup>a</sup>*School of Mechanical Engineering., REVA University, Bengaluru- 560064*

<sup>b</sup>*Professor & Head, School of Mechanical Engineering, CMR University, Bengaluru.*

## Abstract

*Product lifecycle management (PLM) is the process of managing the entire life cycle of a product from its conception through design, manufacture to service, disposal and to some extent even after disposal. PLM integrates people, data, processes and business systems which provide a product information backbone for companies and their extended enterprise. In the face of the turbulent dynamic global markets, manufacturing enterprises are forced in to collaborating with their customers and suppliers more tightly in order to produce high quality products in smaller batches, with shorter lead times and more varieties. PLM describes the engineering aspect of a product from managing descriptions, properties of a product through its development and useful life. PLM is not just about technology, it is a new wave in the production and it is a strategic business approach that includes innovation around products and processes. Utilizing PLM technologies in manufacturing enterprises is an efficient approach realizing the above object; product modeling during its entire lifecycle is recognized to be fundamentally critical to implementing PLM systems.*

**Keywords:** PLM; Lifecycle; Data processing.

## I. INTRODUCTION

Product Lifecycle Management (PLM) is an information technology-based concept bringing several benefits to product development organizations. Product Lifecycle Management (PLM) is an integrated, information-driven approach comprised of people, processes/practices, and technology to all aspects of a product's life and its environment, from its design through manufacture, deployment and maintenance-culminating in the product's removal from service and final disposal [1]. The tendency is to use a PLM strategy to integrate people, processes, business systems, and information in order to manage the product development and support its lifecycle [2]. PLM means product lifecycle management and its value is increasing, especially for manufacturing, high technology and service industries [3].

Product Lifecycle Management (PLM) is an information technology (IT) concept whose aim is a more effective and more efficient flow of product definition information through all phases of the product lifecycle. The use of computers, with virtual reality descriptions and simulations, and databases containing information of real products, enables organizations to develop products in ever shorter times, at ever lower costs and of ever increased product quality.

Product Lifecycle Management (PLM) enables the kind of convergence that Enterprise Resource Planning (ERP) and Customer Relationship Management (CRM) prompted in the past. In the early 90s, ERP unified finance, HR, manufacturing and warehouse systems. A decade later, CRM brought call centre and sales force automation together. Now, Computer-Aided Design (CAD), Computer-Aided Manufacturing (CAM), Product Data Management (PDM) and manufacturing process are converging through PLM. Yet PLM is unique from other enterprise software solutions because it focuses on driving top-line revenue from repeatable processes. Through PLM, the

products are a path to innovation, industry leadership, and top-line growth[4].

The Product Lifecycle Management concept holds the promise of seamlessly integrating all the information produced throughout all phases of a product's lifecycle to everyone in an organization at every managerial and technical level [5]. The strategy of PLM is to build up extended enterprise based on web and support all the suppliers, partners and trusted customers to capture, manage, evaluate and utilize all the related information [6].

The product life cycle management by a PLM solution allows including, not only all the necessary elements to ensure its traceability, like modeling, document management, numerical analysis, know-how capitalization, etc. but all the information system components making it possible to ensure the product monitoring from its manufacture to its marketing until its disappearance or likely its recycling[7].

Product lifecycle management has been accepted by both the academia and industrial alike as fundamental to the product development process in such manufacturing environment [8].

## II. DEFINITION OF PLM

PLM as “the business activity of managing, in the most effective way, a company's products all the way across their lifecycles, from the beginning including development, through growth and maturity, to the end of life.” Besides he describes the creating value dimension describing that “the objective of PLM is to increase product revenues, reduce product-related costs, and maximize the value of products for both customers and shareholders.” Stark does not consider the technological and collaborative features that have instead a primary role in this study [9].

Product Lifecycle Management proposes one of the most exhaustive PLM definitions that are the result of a careful analysis of some existing PLM interpretations. According to Grieves “PLM is an integrated, information-driven approach comprised of people, processes/practices, and technology to all aspects of a product's life, from its design through manufacture, deployment and maintenance-culminating in the product's removal from service and final disposal.” The author specifies the PLM ability to create value through a correct information management and resumes the importance of the duration of PLM as in Stack pole's definition. He views PLM as an outcome of “lean thinking,” the evolution of the lean manufacturing, pointing out the ability of PLM to reduce “wasted time, energy, and material across the entire organization and into the supply chain,” not only during the phase of product manufacturing but also in all the product lifecycle phases. Nevertheless, the definition lacks technological features [10].

PLM as “an integrated approach” that includes “a consistent set of methods, models and IT tools” for the management of “product information, engineering processes and applications” in all “the different phases of the product

lifecycle.” Contrary to other definitions, the author considers the integration of methods, models, and IT tools, but not of people, processes, and data; besides there is not any reference to technological data characteristics and collaborative features [11]. Product Lifecycle Management, consider PLM from a managerial and technological point of view describing it as “a holistic approach that uses a wide range of different concepts, technologies, and tools,” adding the collaboration perspective through the extension of “groups beyond the functions of a company or even a supply network in order to manage and control the lifecycle of a product.” The authors propose a PLM definition covering every set of features discussed in this review, even if they do not deepen every key element and do not give an exhaustive characterization [12].

PLM “is not only an individual computer software but, moreover, it is related to a broad management concept which depends on the integration of multiple software components” [13] in this he illustrate a PLM framework where PLM definition is a key element and provides the boundaries of process models. They develop PLM definition in seven main concepts starting from the integrated management of ideas, projects, and product portfolio, through the requirements management and ending with service and maintenance data reuse in the product development. They underline the importance of the product and processes integration, the lifecycle impact analysis, and lifecycle costs but do not refer to the sharing aspect and to the technology features.

PLM is viewed as a system that supports the evolution and change of data during the product lifecycle. They emphasize the relevance of PLM to “optimize business processes” as “system integrations spanning multiple phases of the product lifecycle.” In this definition, PLM is not considered as a business approach that creates value for the enterprise [14]. The importance of PLM is in the different phases of the product lifecycle, and it is considered as a “strategic approach” necessary to “creating and managing a company’s product-related intellectual capital” [15].

“PLM is a strategic business approach that applies a consistent set of business solutions in support of the collaborative creation, management, dissemination, and use of product definition information across the extended enterprise, and spanning from product concept to end of life-integrating people, processes, business systems, and information. PLM forms the product information backbone for a company and its extended enterprise.” According to CIM data (2002), a research firm focused on PLM, proposes a very comprehensive definition.

PLM is “the process of managing product-related design, production and maintenance information”; it “also may serve as the central repository for secondary information.” The new aspect is the idea that PLM stores data indirectly related to the product, such as “vendor application notes, catalogs, customer feedbacks, marketing plans, archived project schedules, and other information acquired over the product’s life” [16].

An open-source PLM system vendor, underlines the importance of PLM in managing people and business processes; in particular it cites that PLM is a “processor system” to manage “anything pertaining to a product,” such as people, data, and processes.

Besides this definition points out the role of PLM as a “central information hub” that manages all the product data to facilitate communication about product information and to support sharing and collaboration between people through all the phases of product lifecycle [17].

One of the first businesses interested in PLM has been the automotive industry. An important definition that covers many features has been developed by Ford Motor Company [17]. It focused on processes, methods, and tools used during all the product lifecycle. These three factors are used together to

“enable creation, update, access, and ultimately, deletion of product data.” In this formulation PLM is not only considered a single tool or model, but it is also defined as something more extended and not only related just to one subset of production data. Also this definition underlines that PLM allows to extend companies across traditional boundaries and to enable collaboration overcoming geographical limits. The features of business strategy, integrated approach, and value creation are missing.

An important PLM definition has been proposed by the National Institute of Standards and Technology (NIST) that tries to investigate the best definitions of product lifecycle management proposing its point of view based on the PLM as “a vision or a business strategy for creating, sharing, managing information about product, process, people and services within and across the extended and networked enterprise covering the entire lifecycle spectrum of the product” [18].

### III. STRUCTURE OF PLM SYSTEMS

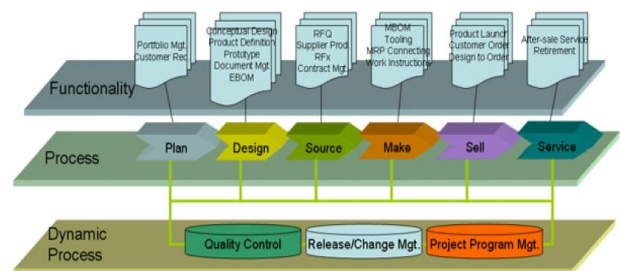

Fig.1. “Structure of PLM System”. Source: Siemens PLM, 2009.

#### A. PLM system requirements

The main goal of a PLM system is to achieve a quick response to a customer’s request for customized products, with compatible product quality and costs, and high quality services. As a strategic business approach, PLM system should support the following key functionalities.

- **Product data management:**

Product lifecycle involves in a large number of data. Product data management is the foundation of product lifecycle management. Through product data integrated management, data consistency could be ensured, and data exchange and transfer between different application modules can be carried out effectively. Product lifecycle management firstly need realize the management of product data [20].

Product Data Management (PDM) has been around for a long time. When 2D CAD systems were first developed, we quickly learned that they are very good at one thing: creating lots and lots of files. As 3D CAD became popular, and more and more product information became a large collection of CAD files, it was hard for people to keep track of all this data. So, PDM systems were developed to allow check-in and check-out of these files from a secure vault. This is the reason that most early PDM systems were nothing more than CAD data vault managers. These PDM solutions not only kept track of relationships between parts and assemblies, but also prevented multiple people from working on the same files at the same time. Thus, PDM became the way that design files were vaulted, tracked, and managed.

PDM is a subset of PLM; it includes the management of intellectual asset information and their relationships. PDM is an important basic requirement that supports PLM, and you cannot do PLM without PDM. PLM includes asset creation through CAD, Analysis, Digital Manufacturing, Documentation, Images, Software, etc... There is generally no creation of intellectual assets

in PDM. There are usually few collaboration capabilities within PDM. However, a strong foundation for PLM starts with a comprehensive and strong PDM solution.

- Plan and Program management:

Product lifecycle development is a kind of system engineering. Product development is a multilayer, multiphase and cooperative operation mode. Plan management and program management can make the product development process standardization and make them to support integrated product development during product lifecycle.

- Development of relation between company and consumer.

A PLM system delivers a product or service based on individual customer demands. In order to achieve such an objective, relations should be created between companies and consumers based on interactions and dependencies that emerge when both people look for mutual understanding to find solutions together.

- Quality requirement.

Quality is a very important aspect of customer requirements. The implementation of quality strategy during product lifecycle process is very effective measure of increasing product quality and reducing product cost. PLM system will be development based on these requirements above.

### B. An architecture of PLM system

A main characteristic of PLM is consistent model of data access through integration of engineering data and business data [21]. PLM solution providers consider PLM as a strategic business approach that applies a consistent set of business solutions [22].

Though the solutions are not same they admit PLM should manage all stages in PL from product requirement to final product disposal. And it should be a platform on which people from enterprises in SC can collaborate with guaranteed permission.

PLM system is a kind of global information integration platform of enterprise. In order to achieve this purpose, the PLM system need be analyzed and constructed from several aspects such as data, function, etc. It can be seen that this kind of PLM system comprises of five layers. It is an abstract architecture model. In practice, the content and form can be detailed according to physical application.

### C. System integration model

The integration model for the proposed is the distributed databases including product, process, code, and customer. They, respectively, store and provide their own data and information, e.g., product, part specifications and definitions can be located in product database. The connection between product database and process database can be captured through codes in code database.

The whole integration process between different subsystems can be grouped into six parts. The main function of an integration component (IC) is to connect legacy systems, e.g., computer aided design (CAD), computer aided process planning (CAPP), and materials resource planning (MRP), which can provide with BOM for a customized product. The consideration of integrating these systems is to maximize their utilization rate and reduce software development cost. The customer relationship management module (CRM) is the agency between customer and enterprise. The product requirement information from customer can be gained effectively through this module. At the same time customer

information can be collected, so enterprise can provide individual service for its customer. It is start point of mass customization production. Product configuration management module (PCM) is designed to configure individual product from the existing product resources if have. Product configuration is one of the key technologies to respond to customer's needs rapidly. The base of its work is the product information master model established in the previous system. Distributed numerical control (DNC) module adopts numerical control machining to mass customization production. Numerical control machining technologies can meet the manufacturing technologies requirement for mass customization very well because of the high flexibility of its control soft. The connection among the aforementioned modules is handled by a module linking component (MLC). Usually, it is an interface aggregate used to process data flow among all modules [20].

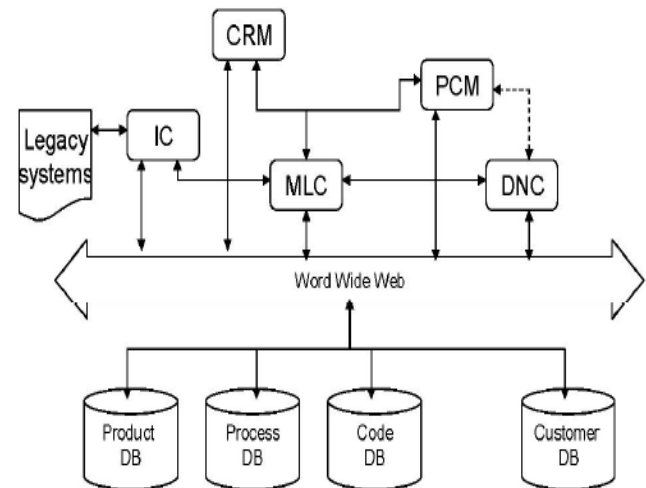

Fig.2. Illustration of system integration model [20]

PLM systems support the management of a portfolio of products, processes and services from initial concept, through design, launch, production and use to final disposal (Figure 1) (Siemens PLM, 2009). They coordinate products, project and process information throughout new product introduction, production, service and retirement among the various players, internal and external, who must collaborate to bring the concept to fruition.

### IV. PLM ANALYSIS

Product life cycle analysis involves a cost analysis of a product over its entire life cycle and is directly related to the product. Product life cycle analysis outlines four stages over the life of a product: introduction, growth, maturity and decline stages. Various factors, i.e., customer needs, innovations and financial needs and rewards, influence the length and shape of the product life cycle in different ways and at different times. In order to succeed in PLM deployment and PLM system implementation, it needs to follow a systematic process or methodology [23]. By acquiring a PLM system it is possible to support Business Process Reengineering for in the fields of product design and after-market activities. In fact the PLM system rarely supports working practices right away, but it requires changes in work processes.

The PLM framework and PLM issues questionnaire developed by Batenburg has been applied to define a PLM guidelines for individual companies [24]. The PLM guidelines process phases include:

- Current PLM maturity and alignment
- Benchmark maturity
- Desired PLM maturity and alignment
- Identify items to be improved
- Define PLM roadmap

The roadmap process is one of the tools that companies could use in their PLM implementation project covering parts of the inclination & design and the implementation preparation phase. Schuh have proposed a PLM process oriented framework that can be applied to guide PLM implementation at the industry [25]. Companies aiming to implement PLM can refer to the provided conceptual framework to establish their own framework, linking the company elements in a complete PLM environment. Therefore, the following ten steps are necessary:

1. Define the goal of the PLM implementation: according to the PLM definition companies can identify the most important points to focus on.
2. Analyze the existent PLM foundation: the ability of the current product structure to support PLM must be analyzed and if necessary enhanced.
3. Rank processes: the processes to be implemented can be selected from the PLM process list, considering company aims and the expected benefits.
4. Identify company maturity level (as-is process): comprehends the mapping of company current processes (only for the previously selected processes).
5. Select an appropriate reference model: from the provided set of reference models it is possible to identify the process type that best suits company characteristics.
6. Customize reference model: although processes that target different kinds of company are available, processes must still be refined to reflect very specific business needs. The customized processes picture the to-be PLM scenario.
7. Specify requirements for system selection: the vendor neutral software requirement catalogue related to the already configured processes provides the system specification.
8. Select software solution: based on previously defined requirements and considering detailed software profiles.
9. Define the evolution path and implement software solution: the differences between the as-is and to-be processes allow the definition of implementation roadmaps, including the necessary implementation of the selected software solution.
10. Teach employees: the knowledge base connection to the processes indicates the new necessary qualification and provide the necessary training material and context.

This implementation approach in ten steps is derived from classical approaches for process engineering [26], but it goes a step further for PLM, as it considers the needs and conditions of this area. As a result, a company specific PLM framework linking process, IT and knowledge is generated. For facilitating the difficulties of PLM implementation for SMEs, software vendors and consultants have recognized and are providing tools and techniques to help reduce the overall change effort. Aberdeen Group [27] identified the most popular methods that smaller companies used to meet their PLM goals and then conducted further analysis to determine which approaches were used by companies that are top performers in meeting product development goals.

Aberdeen Group found that best-in-class companies are taking advantage of implementation aids such as templates, adopting industry-specific solutions where available, and modifying solutions where required. In fact, these approaches were more common among the top performers than among other companies surveyed – indicating that these approaches improve the ability to use PLM to better meet product development targets. PLM product offerings that help small scale companies to achieve the available benefits are emerging, leading to increased adoption by small and medium sized enterprises. However, achieving value requires more

than just PLM software. It also requires efforts to transform the organization and business processes, in combination with the underlying supporting technology.

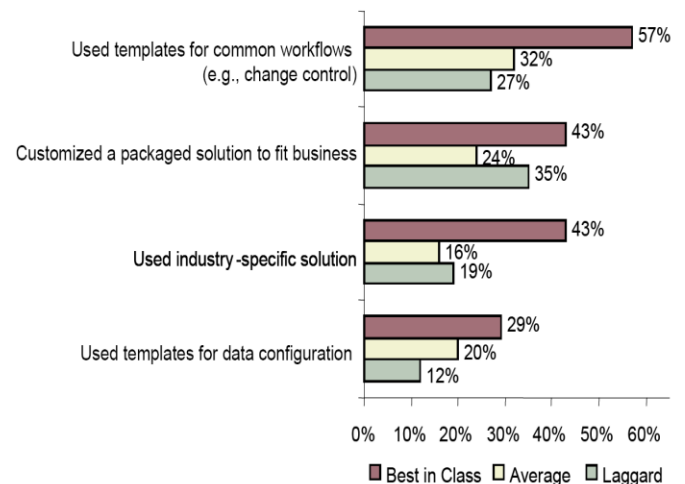

Fig.3.Successful PLM Implementation Approaches [27]

## V. PLM - BUSSINES STRATEGY

PLM provides customers, developers, manufacturers and suppliers with the most effective means of collaboratively managing business activities throughout product development. PLM supports the capability of innovation, creation, management, share, and use of product data, information and knowledge in virtual enterprise networks by integrating people, processes and technology.

As an information technology strategy, PLM establishes a coherent data structure that enables real-time collaboration and data sharing among geographically distributed teams. PLM lets companies consolidate multiple application systems while leveraging existing legacy investments during their useful lives.

PLM systems manage a portfolio of products, processes, and services from its initial conception, through design, manufacture and supply, to service and disposal. Throughout the entire product lifecycle there exist three major objectives, which are:

Customer benefit such as product quality and serviceability, company benefit such as product cost and profit, and society benefit such as clean and green environment.

To reach customer benefits (customization, time-to-innovation, product quality and reliability) are recognized as the key approaches enabled with technologies e.g., product family design, platform based design, modular product design, design process modeling and management, design knowledge management, collaborative design engineering, function/behavior/ structure design, etc.

To achieve company benefits, time-to-market, time-to volume, and time-to-profit are known as the key approaches enabled with technologies, e.g., collaborative product service, product lifecycle process management, product lifecycle information and knowledge management, etc.

To obtain society benefits, design for service, design for reuse and design for recycle are justified as the key approaches enabled with technologies, e.g. product/ service co-design, collaborative early design for lifecycle efficiency, environmentally design, etc.

PLM software itself is just a tool and cannot make many contributions if the PLM process is not defined first and understood by its users whom it should contribute to at the end.

Setting up PLM within the company is a process and project itself. Implementation of the PLM concept in the enterprise enables to cost effectively deliver product enhancements,

derivatives, niche offerings and add-ons that extend the profitable duration of the product lifecycle. PLM facilitates this objective by enabling to create product platforms that accelerate start up processes, minimize time to market cost and maximize the revenue generated by a product's initial release.

The most important part of the PLM model is information. Following the characteristics of a product's life, the PLM model includes the following divisions: plan, design, build, support, and dispose.

The plan division is the study and examination of the future product before it is introduced into the market. All the characteristics of the product itself are analyzed in this phase with special emphasis is given to technical and engineering attributes. According to lean manufacturing strategies, the planning of a product should be based on customer needs and demands. In order to avoid any waste (extra inventory, extra cost, defects etc) it is important to anticipate demand and plan the production, in quality and quantity, according to what the customer wants.

There are several ways in which the product can be manufactured. In the design phase the physical attributes such as colour, form and size of the product have a great importance and quality standards are also taken into account. Based on all attributes and requirements, the production engineers actually build the units and make sure design is achievable.

The building process involves all manufacturing procedures such: factory selection, machinery, materials, and the most qualified work force. It is not uncommon to discover that an apparently good design is actually not feasible. The assembly department will inform if indeed the machinery is appropriate to make a particular creation or if there are necessary tools, or human skills, to convert a sketch into a real product.

The support of a product can be divided into two goals: the marketing of the product and the maintenance of it. Marketing is informing the customers about the product and how to obtain the best performance of it. Maintenance has to do with solving any technical problem that may arise.

The last stage of the PLM model, dispose, has to do with all possibilities of reuse, reprocessing or any potential salvage of the product.

The figure below shows the relationships between these enterprise solutions. Product businesses have at their core the intellectual assets describing their products [28].

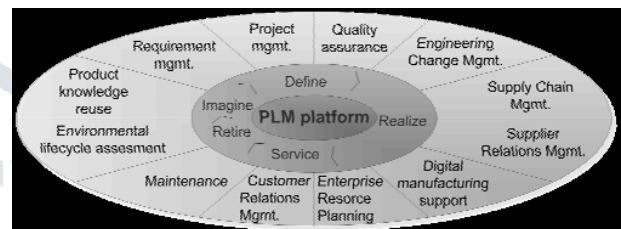
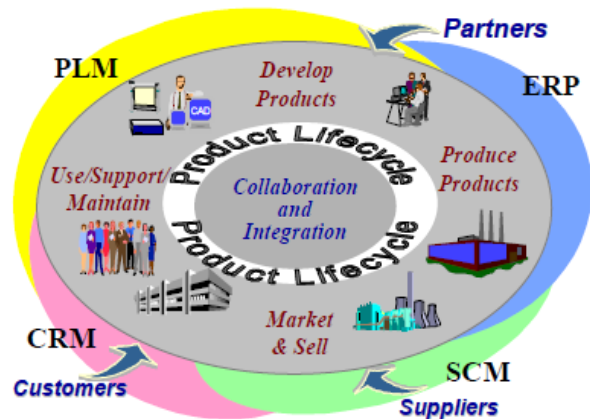

Fig.4. Relationships among Enterprise solutions [28]

## VI. IMPLIMENTATION

Product lifecycle management is about getting from start to finish in the most direct, effective manner possible.

Manufacturers around the world have the same basic elements to manage. These have not changed much over time. However technology and process innovations have changed dramatically. An important factor for improving the efficiency of PLM models is the implementation of information science new tools and technologies [29].

An effective PLM solution will accelerate speed, eliminate unnecessary costs and can improve innovation. It will provide reliable information to help management make superior decisions. Each and every productivity gain you can achieve will lower the costs or increase the productivity of work related to designing, sourcing and manufacturing products your markets. So the outcomes of success can be measured by increment of bottom line profit.

PLM is ultimately about the search for and implementation of the best technologies and process innovations to do the work of designing, sourcing, and manufacturing products for your markets at the lowest costs and highest productivity per head count available at the time.

There are two critical factors that contribute to the successful outcome of any process improvement project: the targets you set and the tools you use. The target defines what you want to achieve, the goal or vision you have for a successful outcome. The tools are used to achieve the desired results defined by the target. In the case of PLM, the tools include resources, processes, applications and data.

PLM is simply business process optimization.

1. The business processes are the design, sourcing, and manufacturing of your products for your markets. Company is doing each of these functions today and it has been doing them ever since the company has been in business. We are not talking about introducing new processes. We're talking about optimizing the processes you are currently doing.

2. Optimization comes from leveraging innovative thinking, bestpractices, and stateoftheart technologies to enable each person in the product lifecycle to work dramatically more effectively [31].

Where you set your process improvement target, or the xfactor, is the first important step in a successful PLM implementation.

Defining success for any process improvement projects includes describing three strategic objectives; the target or desired results, the timeline, and the budget.

1. The target defines what you expect to achieve.
2. The timeline may be to complete the project.
3. The budget would define the upfront investment and the expected ROI including the expected time it will take to return the initial investment and anticipated long term returns of improved profitability.

With the target set and the objectives clearly defines, let's shift attention to the first of the 4 tools, beginning with Resources. To pull your team together, begin by deciding the optimal number of resources for your business size and determining what skills you want each to bring to the project. The project manager is the most critical and often comes from IT. Other IT resources such as business analysts and programmers should find a home on your team as well. Business resources will represent the various functional areas, and key managers will act as stakeholders. Senior management should be identified for the steering committee to govern the project and decide any impediments that arise. Don't forget about outside resources such as overseas offices, licensees, etc that can add value to your endeavors.

Specialists or consultants should be included to augment internal knowledge and bring a fresh approach to the project as with any business improvement project, backfill might be necessary [32].

Consider whether these resources are long or short term, or perhaps full time. While considering who your key project resources are, you must have a transition plan defined to outline:

- Whether resources will offload job responsibilities during the project or manage both simultaneously
- When and how will they transition back if they assume a full time role on the project.
- Whether stakeholders or managers be involved more >50% of the time.
- ask to meet the intended PM, solution architects and business analysts
- check their credentials to ensure they have the domain expertise to help you through your project. Once the optimal team is in place roles must be determined with responsibilities assigned to each member of the team.
- A knowledgeable PM is critical to keep the project on time and under budget
- Key business personnel should be assigned to represent each functional area processes and data and be empowered to make decisions regarding business changes
- Determine who will document the processes and data for configuration, you or the vendor

PLM is a huge undertaking for a company and should not be considered lightly. Participation is critical, and resources should be augmented without resources if users cannot or are not encouraged contribute fully.

With the internal team selected and the responsibilities assigned, it's time for a sober assessment and gap analysis of the skill sets, experience and time availability of the team members needed to ensure a successful project. If gaps exist, fill them at the start of the project so the necessary skills and expertise can positively influence and impact the project.

Options for advisors because there are many types:

- Specialists in areas like CAD/images
- Systems integrators
- Management consultants

- Industry or technology analysts

Content providers are also actionable resources that contribute immense value.

1. Look at the type of data and breadth of data you will be housing in your application
2. Look for information that changes often that could be handled via content providers vs. employing someone in house
3. Consider how the specific data affects the bottom line. For instance, trade compliance missteps could cost companies millions of dollars in penalties if not executed properly.
4. Look at the specialist areas such as patternmaking, import rulings, and color management [33& 34].

## VII. APPLICATION OF PLM

Appropriate system integrations and use of PLM tools (software and hardware) in modern manufacturing companies will help enhance their collaborations and decrease their inefficiency by accurate and prompt usage of information. The cumulative gains (growth in revenue and profit) in an organization can be assured by increasing the efficiency through continuous improvements in PLM technology adopting new strategies and by using new tools.

PLM can largely be considered as an informational core which can be accessed through user-friendly interfaces (Graphical User Interfaces or Application Programming Interfaces) configured with various functional areas in such a way that information is shared and secured among each area through some collaboration protocols. Most of the enterprises system applications such as CRM, ERP and SCM are also embedded in PLM. The tools in PLM may include CAD/CAE/CAM or (CAX) software, DFA/DFM or (DFX) software, tools for Computer Aided Process Planning (CAPP), e-commerce tools, office tools for documentation, encryption software for security and storage, and other user interfaces for hardware tools, multimedia tools and digital manufacturing tools such as Computer Numerical Control (CNC) machines, RP machines etc. All this applications or interfaces may be accessed either through intranet or internet facilities [35]. The available PLM soft-ware tools can be clustered in three groups [36]:

- Information management (e.g. methods for identifying, structuring, classifying, modeling, retrieving, sharing, disseminating, visualizing and archiving product, process and project related data).
- Process management (e.g. methods for modeling, structuring, planning, operating and controlling formal or semi-formal processes like engineering release processes, review processes, change processes or notification processes).
- Application integration (e.g. methods for defining and managing interfaces between PLM and different authoring applications like CAD, CAM, CAE and integrated enterprise software such as ERP, SCM or CRM).

### A. Medium scale to large scale organization

In the current economic scenario, addressing global business challenges is the top priority of most medium and large organization. Whether they want to expand their customer base in new markets, or to reduce more cost competitive resources, conducting their business globally is a necessity. To sustain an advantage, they have to overcome the challenges of a dispersed organization, while still empowering individual team members to excel.

PLM concept offers comprehensive solutions to help organization address their challenges and create competitive advantage.

Five areas where medium and large organization should have achieved success include:

- Managing product and manufacturing complexity.
- Managing new product introduction, to create a product popular in the market.
- Achieving concurrent engineering globally, to be faster to market.
- Supporting products currently in-service, to ensure they are available for use at minimum cost
- Creating platforms for reuse, to reduce cost and speed product customization.

#### B. Small scale to medium scale organization:

Small and medium scale organizations have special needs and limited resources. PLM concept brings a complete solutions designed specifically for them; solutions that help them respond better to their customer's needs.

Small businesses need a product lifecycle management solution designed from the ground-up –one that is pre-configured with the industry's best practices, and offers fast and affordable deployment. Fully integrated PLM solutions are designed to provide what small and medium enterprises need to maximize their innovation strategy, and easily scale to meet their needs tomorrow. Number of PLM software available in the world to help mid-sized manufacturing companies to transform their process of innovation by applying predefined best practices to everyday engineering tasks and processes. Companies using PLM software benefit from:

- A more successful move from 2D to 3D.
- Securing their corporate design data while facilitating access by authorized personnel.
- Increasing their design reuse, facilitated by a powerful and flexible search capability.
- Error reduction through more effective collaboration between their departments and the elimination of mistake manual handoffs to manufacturing.
- Rapid deployment of a full-featured product data management (PDM) solution.
- Low total cost of ownership.
- Streamlining their engineering process with simple design review and release workflows and effective change management.

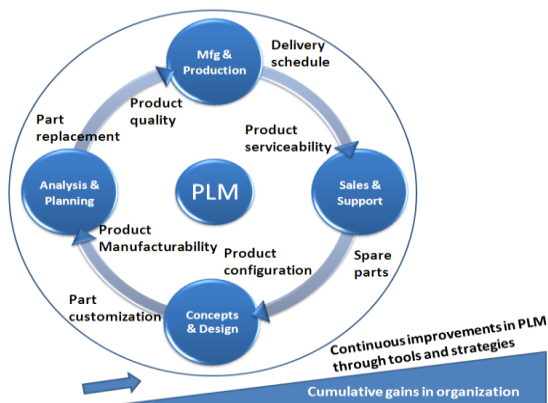

Fig.5. Structure of collaborations in PLM portal for major inter and intra-organizational activities [35]

Companies achieving great success with PLM are focused in the following industries: Aerospace & Defense, Automotive, Consumer Goods, Education, Energy, Financial, Food & Beverage, Government, Healthcare, High Tech Electronics, Industrial, Medical Devices, and Pharmaceutical.

## VIII. CONCLUSIONS

PLM as a tool which helps to quantify the performance over a period also helps in meeting the customer expectations about both the product and the process. Several studies are available on PLM, but these definitions give the states of art introducing to do further studies on overall view for both new and old organizations. PLM is to be used for execution and decision making within the organization responding to the rapid changes in the business environment. In this context an outline of advanced PLM-system architecture is reviewed which makes use of these methods and integrates data from the product operation phase to disposal. The importance of this review paper is to improve the understanding between the development in different stages of a product and the ways in which the information and knowledge can be managed among all stages.

This paper highlights on the structure, analysis, strategies and applications of PLM which are considered as an important step towards implementing PLM as a useful methodology in management levels in an organization or industries which leads to exponential growth of the organization in the global market.

## REFERENCES

- [1] Grieves, M. (2006). Product Lifecycle Management: Driving the Next Generation of Lean Thinking. New York, McGraw-Hill.
- [2] S. G. Lee, Y.-S. Ma, G. L. Thimm, and J. Verstraeten, "Product lifecycle management in aviation maintenance, repair and overhaul," *Computers in Industry*, vol. 59, no. 2-3, pp. 296–303, 2008.
- [3] A. Saaksvuori and A. Immonen, *Product Lifecycle Management*, Springer, Berlin, Germany, 2nd edition, 2008.
- [4] Saaksvuori & Immonen, 2008; Grieves, 2009; Bernard & Tichkiewitch, 2008; Stark, 2004).
- [5] Conceptual Framework for Product Lifecycle Modeling, 2006-Wenlei Zhang and Yushun Fan.
- [6] CIM data, "Product Lifecycle Management, Empowering the Future of Business", www.cimdata.com, 2002.
- [7] Souheil ZINA "modeling and configuration management in Product Lifecycle Management" (CESA)- 2006, Beijing, China.
- [8] Angelo Corallo- Defining Product Lifecycle Management: A Journey across Features, Definitions, and Concepts- ISRN Industrial Engineering Volume 2013, Article ID 170812.
- [9] Stark, *Product Lifecycle Management: 21st Century Paradigm For Product Realisation*, Spinger, London, UK, 2011.
- [10] M. Grieves, *Product Lifecycle Management: Driving the Next Generation of Lean Thinking*, McGraw-Hill, New York, NY, USA, 2006.
- [11] M. Abramovici, "Future trends in product lifecycle management (PLM)," in *The Future of Product Development*, F. Krause, Ed., pp. 665–674, Springer, Berlin, Germany, 2007.
- [12] A. Saaksvuori and A. Immonen, *Product Lifecycle Management*, Springer, Berlin, Germany, 2nd edition, 2008
- [13] G. Schuh, H. Rozenfeld, D. Assmus, and E. Zancul, "Process oriented framework to support PLM implementation," *Computers in Industry*, vol. 59, no. 2-3, pp. 210–218, 2008.
- [14] R. M. Rangan, S. M. Rohde, R. Peak, B. Chadha, and P. Bliznakov, "Streamlining product lifecycle processes: a survey of product lifecycle management implementations, directions, and challenges," *Journal of Computing and Information Science in Engineering*, vol. 5, no. 3, pp. 227–237, 2005.
- [15] S. Rachuri, E. Subrahmanian, A. Bouras, S. J. Fenves, S. Fofou, and R. D. Sriram, "Information sharing and exchange in the context of product lifecycle management: role of standards," *CAD Computer Aided Design*, vol. 40, no. 7, pp. 789–800, 2008.
- [16] Active Sensing Inc. report, 2008.
- [17] Aras Corporation, report-2011
- [18] Ford Motor Company, "Definition of PLM," in *University of Michigan's AUTO, Conference for IT, Engineering, and Manufacturing Automotive Executives*, 2004.
- [19] R. Sudarsan, S. Fofou, and S. J. Kemmerer, "Analysis of Standards for Lifecycle Management of Systems for US Army— a preliminary investigation," *Tech. Rep. NISTIR 7339*, National Institute of Standard and Technology Administration, Department of Commerce, Gaithersburg, Md, USA, 2006.
- [20] XU Xin-sheng, FANG Shui-liang, GU Xin-jian A Framework for Product Lifecycle Management System-P.R.China.

- [21] Guo Gang, Yu Chenglong and Liu Fei, Connotation and Technology Architecture of Product Lifecycle Management, China Mechanical Engineering, 2004, 06, pp.512-515.
- [22] CIMdata, "Product Lifecycle Management, Empowering the Future of Business", www.cimdata.com, 2002
- [23] Gaaloul, H. (2007). Product Lifecycle Management Implementation and Industrial Benefits for Mid-Size Market. M.Sc. Thesis. Cranfield University. School of Applied Sciences.
- [24] Batenburg, R., Helms, R. W. & Versendaal, J (2006). PLM roadmap: stepwise PLM implementation based on the concepts of maturity and alignment, International Journal of Product Lifecycle Management 1(4), 333 – 351.
- [25] Schuh, G., Rozenfeld, H., Assmus, D. & Zancul, E. (2008). Process oriented framework to support PLM implementation, Computers in Industry 59 (2008) 210–218.
- [26] Davenport, T. (1993). Process Innovation: Reengineering Work Through Information Technology, Harvard Business School Press, Boston.
- [27] Aberdeen Group (2006). The PLM for Small to Medium-Size Manufacturers Benchmark Report. Enabling Profitable Growth for SMEs. Boston: Aberdeen Group Inc. pp. 21
- [28] Gecevska V., Veza I., Cus F., Anisic Z., Stefanic N., "LeanPLM - Information Technology Strategy for Innovative and Sustainable Business Environment", International Journal of Industrial Engineering and Management (IJEM), Vol.3 No 1, 2012, pp. 15-23.
- [29] Aristeidis Matsokis and Dimitris Kiritsis -Ontology applications in PLM- Int. J. Product Lifecycle Management, Vol. 5, No. 1, 2011
- [30] The Optimize Solution, Dependable Knowledge Drives process Improvement & ROI in Global Sourcing, by Matt Gersper, Global Data Mining
- [31] Does your Technology Meet your Global Business Needs- Setting Up a Project...Properly, by Nancy Johnson, Optimize LLC
- [32] Product Development Rules for the New Era: A Perspective on Why the Rules Need to Change, by Nancy Johnson, Optimize LLC
- [33] Time to rethink offshoring, by Ajay K. Goel, Nazgol Moussavi, and Vats N. Srivatsan, McKinsey & Company
- [34] New Classification System Helps Achieve True Compliance, by Matt Gersper, Global Data Mining
- [35] Rajashekar Patil, S. Mohan Kumar and E. Abhilash. Tools and Strategies for Product Life Cycle Management – A Case Study in Foundry-International Journal of Advancements in Research & Technology, Volume 1, Issue3, August-2012 1 ISSN 2278-7763.
- [36] Madjid Fathi, Alexander Holland, Michael Abramovici and Manuel Neubach, "Advanced Condition Monitoring Services in Product Lifecycle Management," Proc. IEEE International Conference on Information Reuse and Integration, pp 245- 250, 13-15 Aug. 2007.

