

# DESIGN A FUZZY TYPE-1 BASED PSS TO DAMP OUT THE INTER-AREA OSCILLATIONS FOR INTER CONNECTED POWER SYSTEM

<sup>1</sup>Md.Raza, <sup>2</sup>Anurag S.D.Rai, <sup>3</sup>Reeta Pawar

<sup>1</sup>M.Tech Scholar, <sup>2</sup>Assistant Professor, <sup>3</sup>Associate Professor

<sup>1,2,3</sup>Electrical Engineering Department

RNTU, Bhopal, India.

**ABSTRACT:**In this paper, designed a Wide Area Damping Controller (WADC) to damp out the inter-area oscillations. The designed approach is Type-1 Fuzzy Logic Sets (T1FLS) based Power System Stabilizer (PSS). To design the WADC, enhance the stability and reduced the cost of the power system, geometric measure of joint controllability/observability is used to select most effective stabilizing signals and control location site in proposed model. Based on joint controllability/ observability Tie-line active power is found to be most stabilizing signal. In this paper, Tie Line active power deviation conjunction with speed deviation are used as a input stabilizing signals and the designed methods are illustrated on Kundur two area four machine system. Proposed controller also considers the Genetic Algorithm (GA) optimized PID Controller. Simulation results revealed that the controller designed on the base of T1FLS able to damp out the inter-area oscillations in terms of settling time, peak overshoot and number of oscillations.

**KEYWORDS:**Wide Area Damping Controller, Type-1 Fuzzy logic sets, Inter-area oscillations, Power system stabilizer, Genetic Algorithm, Proportional-Integral-Derivative Controller (PID).

## INTRODUCTION

Now a days, the continuous inter-connection of regional electric grid is the developing trend of modern power system all over the world, such as interconnection of national grids of India, Europe network, the Japan power grids, the national grids of China and North American power grids. The main reason for interconnection of electric grids is that it can efficiently utilize various power resources distributed in different areas and achieve the optimal allocation of energy resources. These also optimize the economic dispatch of power and get relatively cheaper power, which implies that decrease of system installed capacity and the investment. Moreover, in case of fault or disturbance in operating condition, it can also provide additional supporting power of each area of interconnected grids which can increase the reliability of generation, transmission and distribution system.

With the growing electricity demand and the aging utility infrastructure, the present-day power systems are operating close to their maximum transmission capacity and stability limit. In the past few decades, the angular instability, caused by small signal oscillations, has been observed in the power systems under certain system conditions, such as during the transmission of a large amount of power over long distance through relatively weak tie lines and under use of high gain exciters. These conditions introduce inter-area oscillations [0.1-1.0 Hz] in the power system and which may cause a black out of the whole power system. If the transmission line had proper compensation in place of reactive power control then such type of black out not happen and it will able to handle even heavily loaded tie line power.

The traditional approach to damp out the inter-area oscillations by using Conventional Power System Stabilizer (CPSS). The basic function of PSS is to add damping to the generator rotor oscillation by controlling its excitation using auxiliary stabilizing signal. These controllers use local signals as an input signal and may not always be able to damp out inert-area oscillations, main cause behind this, the design of CPSS based on system components linearization around one operating point. Also local controller have not global observation and may does not be effectively damped out the inter-area oscillation. The loads are varies in infinite way so in each condition operating point also changes hence it is not possible to design a controller at one particular operating condition. In resent year nonlinear control techniques gain more attention and it is applied to the power system

To design CPSS, there are several linear and non-linear methods are reported in [1]. Different types of intelligent technique are used as PSSs and successfully applied in improving the power system stability like Neural Network [2-4], Fuzzy logic controllers [5-8] and hybrid neuro-fuzzy controllers. Many researcher have applied different types of optimization technique like Genetic Algorithm (GA), Particle Swarm Optimization to find out the optimal value of tuning parameters of the Lead-Lag Compensator (LLC), Proportional-Integral-Derivative (PID controller and fuzzy logic controller to obtain improve results. It is well known fact that the LLC is the main component of CPSS and generally used to compensate the phase lag between the excitation voltage and electrical torque of the synchronous machine [14]. Selection of parameters for the compensator at different operating point is a challenging task. Some researchers proposed a simple PID controller in place of LLC to perform the same task. Also tuning of PID parameters for different condition is difficult.

Fuzzy controllers are mostly used for the system which are complex and mathematically ill define. It is applied almost all areas of power system problem. Development of fuzzy logic based power system stabilizer to assure system stability and enhance the performance of a power system is described in this paper. Generally the fuzzy logic based PSS used speed deviation and its

derivative i.e. acceleration as their input signals. But in this paper, a new input signal i.e. tie line active power deviation is used in conjunction with local speed deviation. The advantage of this input is that, the same signal is used for each fuzzy logic PSS, which reduce cost, scanning time, and thus simple in structure. In this paper, output of fuzzy logic controller is fed to PID controller which was optimized by GA based on theIntegral of Time Error (ITE) criterion.

This paper is structured as follows: Section II presents the brief review on fuzzy logic system; section III briefly discusses signal selection and control location site for controller, based on geometric measured of joint controllability/observability. Design of power system stabilizer based on fuzzy logic discussed in section IV. Simulation results of the proposed controller & comparison are briefed in section V and finally the conclusion is presented in section VI.

## II. BRIEF REVIEW ON FUZZY LOGIC SYSTEM

Fuzzy control systems are rule-based systems in which a set of ‘fuzzy’ rules represents a control decision mechanism to adjust the effects of certain system disturbances. Fig.1 illustrates the basic structure of a fuzzy logic controller with a fuzzification, inference mechanism, rule base & defuzzification [5]. The knowledge-based module contains knowledge about all the input and output fuzzy partitions [6]. The aim of fuzzy control systems is to replace a skilled human operator with a fuzzy rule based system. The fuzzy logic controller provides an algorithm to convert the linguistic control scheme (which is based on expert knowledge) into an automatic control scheme.

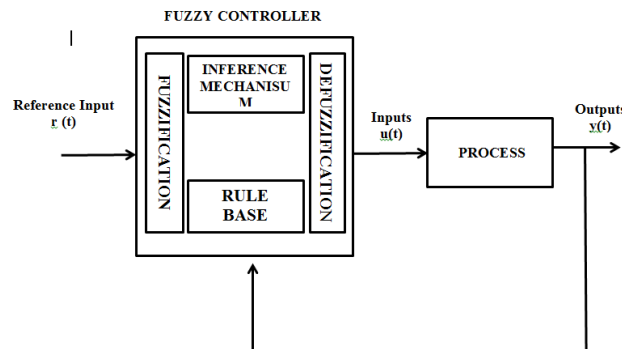

Fig. 1 basic structure of a fuzzy logic controller

The fuzzy controller has following main components:

**Fuzzification:** The fuzzification is a process by which the crisp input control variables are transformed into fuzzy linguistic variables using normalized membership function.

**Knowledge Base and Inference Mechanism:**The fuzzy logic inference mechanism is the part responsible for deducing the proper control action based on available rule base. The knowledge base includes the definition of the fuzzy membership function defined for each control variable and the required rules that determine the control action using linguistic variables. It enables the controller to map the input fuzzy sets to the output fuzzy sets through control rules in the form of IF-THEN statements. This part of control design allows for incorporating the human experience in the design process as some of these rules can be derived based on past experience, knowledge acquired through off-line simulation, understanding of dynamics of the involved system and common sense engineering judgment. The required number of control rules depends on the number of linguistic variables being assigned to each input variables.

**Defuzzification:** The defuzzification is a process by which the fuzzy linguistics output control action is transformed into proper crisp values using normalized membership function.

## III. SIGNAL SELECTION AND CONTROL LOCATION SITE

In development of WADC model, each generator of proposed model has 11 state variables. Therefore, as per Kundur four machine model adapted in this research the total order of the non-linear system has 44 state variables. After linearizing the non-linear test system about stable operating point of tie line active power whose initial value is 413 MW, the small signal analysis was undertaken using the PST.This resulted in two critical inter-area oscillations modes characterized by their damping ratio and frequency which are tabulated in Table-I.

Table-I Inter-Area Mode of Oscillation of Two Area Four Machines System

Mode No.	Eigen Value	Damping Ratio	Frequency (Hz)
5	$-0.25 \pm 6.5i$	0.36	0.1
15	$0.05 \pm 4.1i$	-0.01	0.65

In case of mode-15, Gen-1 and Gen-2 form one area and Gen-3 and Gen-4 form another area and they are oscillating with respect to each other.

The geometric measure of controllability  $gm_{ci}(k)$  and observability  $gm_{oj}(k)$  associated with the mode  $k^{th}$  are given by[12]:

$$gm_{ci}(k) = \cos(\alpha(\psi_k, b_i)) = \frac{|\psi_i b_i|}{\|\psi_k\| \|b_i\|} \tag{1}$$

$$gm_{oj}(k) = \cos(\theta(\phi_k, c_j^T)) = \frac{|c_j \phi_k|}{\|\phi_k\| \|c_j\|} \quad (2)$$

In equation (1) and (2),  $b_i$  is the  $i^{\text{th}}$  column of matrix B corresponding to  $i^{\text{th}}$  input,  $c_j$  is the  $j^{\text{th}}$  row of output matrix C corresponding to  $j^{\text{th}}$  output.  $|z|$  and  $\|z\|$  is the modulus and Euclidean norm of  $z$  respectively.  $\alpha(\psi_k, b_i)$  is geometrical angle between input vector  $i$  and  $k^{\text{th}}$  left eigenvector and  $\theta(\phi_k, c_j^T)$  geometric angle between the output vector  $j$  and  $k^{\text{th}}$  right eigenvector. The joint controllability and observability index of geometric approach is defined by:

$$C = gm_{ci}(k) * gm_{oj}(k) \quad (3)$$

In the geometric approach it can prove that, higher the value of joint controllability and observability index more the stability of signal selected.

Geometric measures are used to evaluate the comparative strength of candidate signal. The candidate input signals are real power of tie-line, generator rotor speed, bus voltage angle difference and centre-of-inertia difference between two areas. However, in this paper two input signals consider for signal selection process based on joint controllability/observability namely tie-line active power and generator rotor speed.

The coloums in Table-II correspond to generators and the rows correspond to measurements.  $P_{i-j}$  denotes the tie-line active power of transmission line connecting bus  $i$  and  $j$ .  $\omega_i$  rotor speed of generator  $i$ . The highest joint controllability/observability indices (0.9269, 1.000) are presented in table-II [12].

Table-II Geometric measure of controllability/observability approach for signal selection for mode-15  
( $0.05 \pm 4.1i$ )

Signals	Generators			
	G-1	G-2	G-3	G-4
$P_{6-7}$	0.2726	0.3588	0.2890	0.3871
$P_{7-8}$	0.7042	0.9269	0.7466	1.000
$P_{8-9}$	0.0685	0.0901	0.0726	0.0972
$P_{9-10}$	0.3629	0.4777	0.3847	0.5153
$\omega_1$	0.0046	0.0060	0.0049	0.0065
$\omega_2$	0.0031	0.0040	0.0033	0.0044
$\omega_3$	0.0069	0.0091	0.0073	0.0098
$\omega_4$	0.0061	0.0081	0.0065	0.0087

#### IV. DESIGN OF POWER SYSTEM STABILIZER

The wide-area fuzzy logic based PSS is designed to damp a critical inter-area oscillation mode- $k$  by providing supplement damping control signal for excitation system of the  $i^{\text{th}}$  generator, and the overall structure of a Wide-area FPSS designed for multi-area interconnected power system is illustrated in figure-2.

The structure of the wide-area PSS is shown in figure-2. The  $V_t$  and  $V_{ref}$  denote the generator terminal voltage and its reference. The local mode is damped by PSS which uses the rotor speed of local generator as input and its parameter is determined based on phase compensation of local mode frequency. The output of wide-area FPSS is added to the excitation system of the selected machine together with the output of the local PSS to provide damping for the inter-area modes.

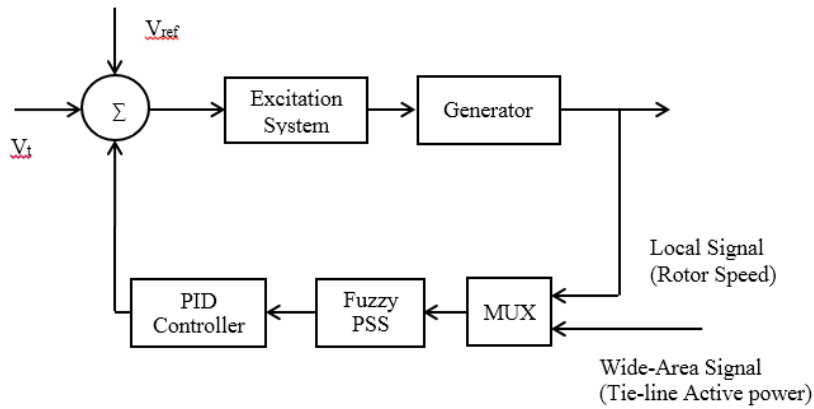

Fig. 2 configuration of the generator with pss

For the test system, G-2 of area-1and G-4 of area-2 are equipped with a LPSS and Wide-area FPSS to damp the local mode oscillation as well as inter-area oscillations conjunction with PID Controller. For this, the value of PID controller is optimized based on Integral of Time Error (ITE) criterion based on GA.

The oscillations of a system can be seen through the tie-line active power deviation or speed deviation of rotor. To minimize the oscillation of any deviation is research objective. For Kundur’s two area four machines system, integral of time error of speed deviation for G-2 and G-4 taken as a objective function (J).

$$J = \int_{t=0}^{t=t_{sim}} |\Delta\omega| \cdot t \cdot dt \tag{4}$$

where  
 $t_{sim}$  =simulation time range.

For a stipulated period of time, the time domain simulation of the above power system is worked out and from the simulation the calculation for the objective function is calculated. The prescribed range of the Proportional, Integral & Derivative (PID) controller is limited in a boundary. Thus the following optimization problem is formulated from the above design approach.

Minimize J  
 Subject to :  $K_{pi}^{min} \leq K_{pi} \leq K_{pi}^{max}$

$$K_{ii}^{min} \leq K_{ii} \leq K_{ii}^{max}$$

$$K_{Di}^{min} \leq K_{Di} \leq K_{Di}^{max}$$

where  $K_{pi}^{min}$ ,  $K_{ii}^{min}$ ,  $K_{Di}^{min}$  and  $T_{pi}^{max}$ ,  $T_{ii}^{max}$ ,  $T_{Di}^{max}$  are the lower and upper bound for PID controllers

The value of optimized PID controller is tabulated in table-III.

Table-III GA Optimized PID Controller Parameters

Parameters	Gain Value
Proportional Controller Gain	19.5396
Integral Controller Gain	0.09
Derivative Controller Gain	0.01

For designing of fuzzy logic controller based PSS on fuzzy Type-1, the input signals to the Fuzzy Logic Controller (FLC) are speed deviation ( $\Delta\omega$ ) and tie-line active power deviation ( $\Delta\omega$ ) based on joint controllability and observability as mentioned in table-II. The output of the FLC will be supplementary stabilizing signal applied to PID controller and output of that controller feed to the voltage regulator of G-2 and G-4. The block diagram representation of FPSS shown in figure-3.

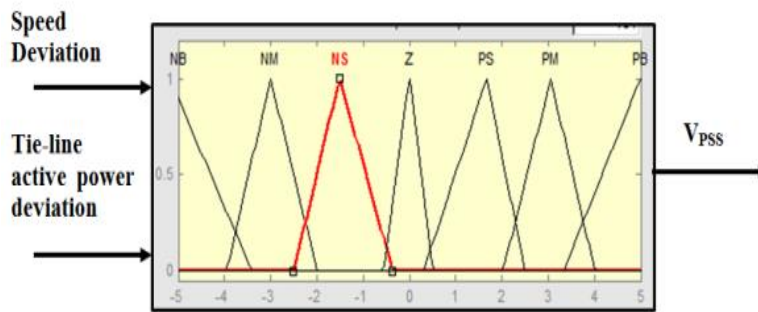

Fig. 3 type-1 fuzzy logic controller pss block diagram

To design the rule base for the fuzzy controller seven membership functions are taken for each speed deviation, tie-line active power deviation and controlled voltage. Total 49 rules bases have been designed for the optimal performance of the proposed controller which is shown in table-IV. For the design of FLPSS, the max-min composition method is used for interface, centroid method for defuzzification purpose. The triangular membership is used for input, output and controlled voltage. The linguistic variables are, NL (Negative Large), NM(Negative Medium), NS(Negative Small), ZE(Zero), PS(Positive Small), PM(Positive Medium) and PL(Positive Large).

The details of rule base that are used in this paper are as follows [13]

Rule-1R<sup>1</sup>: IF speed deviation ( $d\omega$ ) is negative large (NL) AND tie line active power deviation ( $P_{act}$ ) is Negative Large (NL) THEN PSS (output of fuzzy PSS) is Negative Large (NL).

Similarly the Rule-7 R<sup>7</sup>: IF speed deviation ( $d\omega$ ) is Negative Large (NL) AND tie line active power deviation ( $P_{act}$ ) is Positive Large (PL) THEN PSS (output of fuzzy PSS) is Zero (ZE).

Table – IV Rule Base for Proposed Type-1 FLC

Speed Deviation (PU) (-0.005 to 0.005)	Tie-line active power Deviation (PU) (-0.4 to 0.4)						
	NL	NM	NS	ZE	PS	PM	PL
	PSS(-0.15 to 0.15) (PU)						
NL	NL	NL	NL	NL	NM	NS	ZE
NM	NL	NL	NM	NM	NS	ZE	PS
NS	NL	NM	NM	NS	ZE	PS	PM
ZE	NM	NM	NS	ZE	PS	PM	PM
PS	NM	NS	ZE	PS	PM	PM	PL
PM	NS	ZE	PS	PM	PM	PL	PL
PL	ZE	PS	PM	PL	PL	PL	PL

V. SIMULATION RESULTS AND COMPARISON

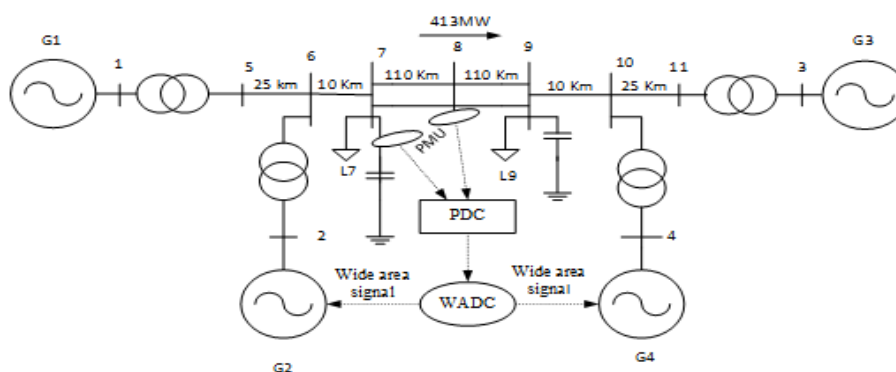

Fig. 4 kundur's two area four machine system

To perform the dynamic analysis of the closed loop test system for Kundur two area four machine systems as shown in fig. 4, a small pulse with magnitude of 5% as a disturbance was applied to the generator G1 for 12 cycles. The simulation time was of 30 seconds. Then the response of tie line active power flow, rotor mechanical angle, rotor speed and rotor speed deviation are examined by considering the test system with CPSS and modified Type-1 FLC with PID controller under the presence of selected feedback signals by geometric approach.

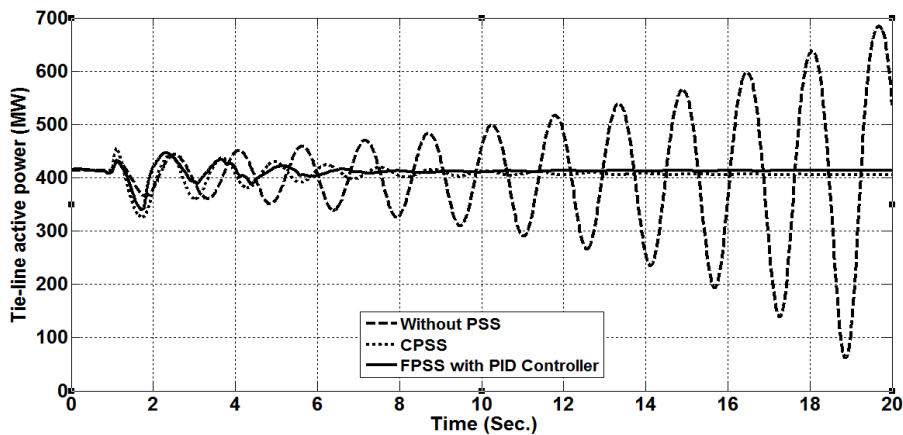

Fig. 5 tie-line active power flow from area-1 to area-2

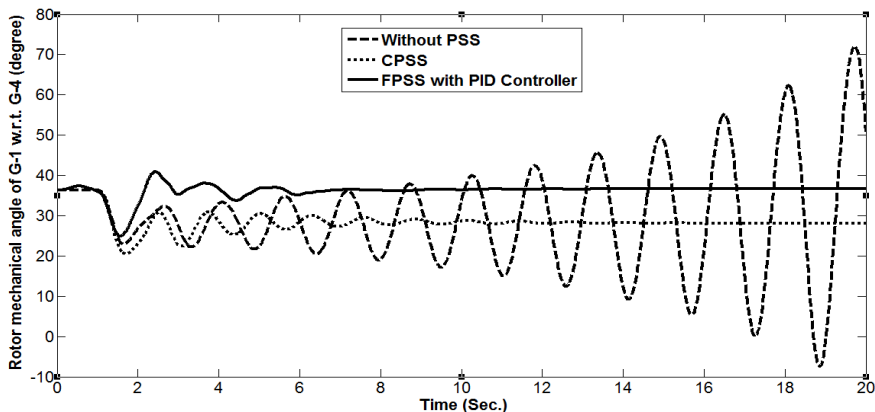

Fig. 6 rotor mechanical angle of g-1 w.r.t. g-4

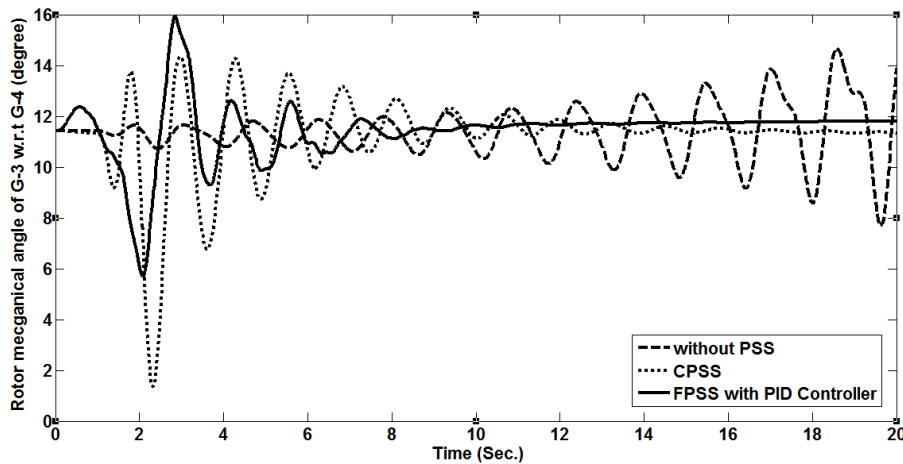

Fig. 7 rotor mechanical angle of g-3 w.r.t. g-4

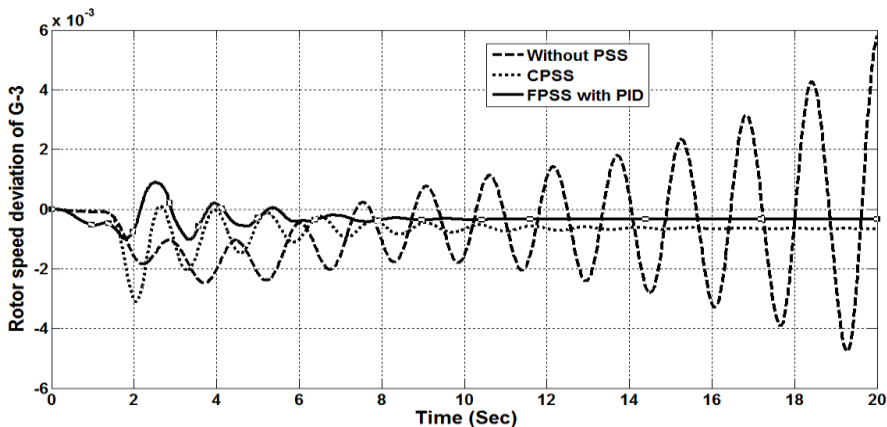

Fig. 8 rotor speed deviation of g-3

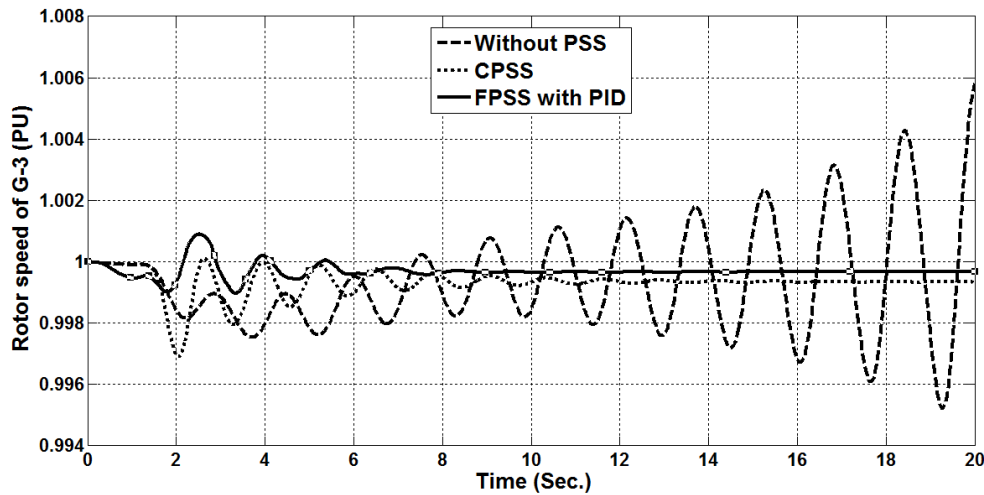

Fig. 9 rotor speed of g-3

## VI. CONCLUSION

In this paper researcher designed a wide-area damping controller to damp out the inter-area oscillations in a large scale power system based on fuzzy logic and PID control. The proposed controller design based on observed signal that can be obtained from the method of geometric measure of controllability and observability associated with the inter-area oscillations mode. Some simulation results are carried out to verify the effectiveness of proposed controller under small disturbance and large disturbance. From the simulation results, it reveals that the proposed controller damps out the inter-area oscillations effectively.

## REFERENCES

- [1] A. A. Ba-muqabel, M. A. Abido, "Review of conventional power system stabilizer design methods," IEEE GCC Conference ~ GCC 2006~, March 20-22, 2006, Manama, Bahrain.
- [2] R. Seagal, A. Sharma, M. L. Kothari, "A self tuning Power System Stabilizer Based on Artificial Neural Network," Electrical Power and Energy Systems, vol. 26, 2004, pp. 423-430.
- [3] D. K. Chaturvedi, O. P. Malik, "Generalized Neuron Based PSS and Adaptive PSS, Control Engineering Practice," vol. 13 n. 12, December 2005, pp. 507-514.
- [4] J. A. L. Barreiros, A. M. D. Ferreira, C. Tavares-da-Costa, W. Barra, J. A. P. Lopes, "A Neural Power System Stabilizer Trained Using Local Linear Controllers in a Gain Scheduling Scheme," Electrical Power and Energy Systems, vol. 27, 2005, pp. 473-479.
- [5] J. Lu, "A Fuzzy Logic Based Adaptive PSS for Multimachine Systems," Electric Power Systems Research, vol. 60, 2001, pp. 115-121.
- [6] J. Lu, "A Fuzzy Logic Based Adaptive PSS for Multimachine Systems," Electric Power Systems Research, vol. 60, 2001, pp. 115-121.
- [7] D. E. Kasov, D. Menniti, A. Pinnarelli, Y. D. Sergeyev, N. Sorrentino, "Tuning Fuzzy Power System Stabilizers in Multi Machine System by Global Optimization Algorithms Based on Efficient Domain Partitions," Electric Power Systems Research, vol. 78, 2008, pp. 1217-1229.
- [8] M. Soliman, A. L. Elshafei, F. Benary, W. Mansour, "LMI Static Output-Feedback Design of Fuzzy Power System Stabilizer," Expert Systems with Applications, vol. 36, 2009, pp. 6817-6825.
- [9] M. Chetty, "A Fuzzy Logic Based Discrete Mode Power System Stabilizer," Asian Journal of Control, vol. 4 n. 3, September 2002, pp. 327-332.
- [10] M. Ramirez-Gonzalez, O. P. Malik, "Power System stabilizer Design Using an Online Adaptive Neurofuzzy Controller With Adaptive Input Link Weights," IEEE Trans. Energy Con., vol. 23 n. 3, September 2008, pp. 914-922.
- [11] D. K. Chaturvedi, O. P. Malik, "Neurofuzzy Power System Stabilizer," IEEE Trans. Energy Con., vol. 23 n. 3, September 2008, pp. 887-894.
- [12] Hamdan A. M. A. and Elabdalla A. M., "Geometric measures of modal controllability and observability of power systems models," Elect. Power Syst. Res., vol. 15, pp. 147-155, 1988.
- [13] N. Nallathambi, P.N. Neelakantan, "Fuzzy logic based power system stabilizer," IEEE Conference, 2004.
- [14] Kundur P, "Power System Stability and Control," New York: McGraw-Hill, 1994.