

A NOVEL ON POWER QUALITY IMPROVEMENT OF SOLAR PV UNDER GRID CONNECTED MODE

S.SUPRAJA¹, T. ISWARYA²

¹Assistant Professor, Department of Electrical And Electronics Engineering, Aits, Tirupati, India, supraja.s12@gmail.com

²Assistant Professor, Department of Electrical and Electronics Engineering, Aits, Tirupati, India, iswaryathotakura@gmail.com

Abstract:- In this paper grid-connected PV system presented. PV system consists of a photovoltaic module, a boost converter, and voltage source inverter. To boost the panel voltage DC-DC boost converter is used and ANFIS based ICM (Incremental Conductance Method) MPPT. ANFIS controller will be a new technique which is often used to optimize the total performance of the Photovoltaic system. In this paper, the grid-connected PV system performance is evaluated and harmonics occurred in the system are optimized. This ANFIS controller is definitely effective, simple and easy at minimal cost. The entire proposed technique continues to be modeled in addition to simulation using Mat lab/Simulink software.

Keywords: Photovoltaic (PV); boost converter; ANFIS controller; Incremental Conductance Method (ICM); Voltage Source Inverter (VSI).

1. INTRODUCTION

It is clear that fossil fuels are mangling the climate and that the status quo is unsustainable. There is a broad scientific consensus that the world needs to reduce greenhouse gas emissions more than 25 percent by 2020[1] and more than 80 percent by 2050. The idea of harnessing the sun's power has been around for ages. The basic process is simple. Solar collectors concentrate the sunlight that falls on them and convert it to energy. Solar power is a feasible way to supplement power in cities. In rural areas, where the cost of running power lines increases.

The need for renewable energy sources is on the rise because of the acute energy crisis in the world today. India plans to produce 20 Gigawatts Solar power by the year 2020, whereas we have only realized less than half a Gigawatt of our potential as of March 2010. Solar energy is a vital untapped resource in a tropical country like ours [2].where, IPV is PV cell current, is submersion current,

It is possible that the world will face a global energy crisis due to a decline in the availability of cheap oil and recommendations to a decreasing dependency on fossil fuel. This has led to increasing interest in alternate

power/fuel research such as fuel cell technology, hydrogen fuel, biodiesel, solar energy, geothermal energy, tidal energy and wind. Today, solar energy and wind energy have significantly alternated fossil fuel with big ecological problems.

2. MODELING OF PV Panel

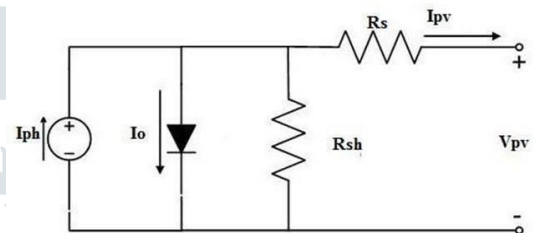

Fig.1 Equivalent Circuit of PV Cell

Figure 1 gives the proportional circuit of PV cell. Characteristics of PV cell can be acquired by utilizing the accompanying equation1

N_s is no. of arrangement associated cells, N_p is no. of parallel associated cells, k is Boltzmann steady (1.38×10^{-19} J/K), q is electron charge equivalent to 1.607×10^{-19} C, T is Nominal temperature, R_s is arrangement obstruction. The non-coordinate condition, generally relies on the light, temperature, and reference esteems. The reference regards normally suited working condition of temperature is 25°C and radiation is 1000 W/m^2 . The quantity of arrangement associated cells is 5 and number of parallel associated cells are [3] of PV

MODELING OF BOOST CONVERTER

To increase the output voltage of PV system, the boost converter is used. MPPT controller gives PWM signals, IGBT is used to control the DC voltage. The boost converter

is controlled using two parameters, (i) PV output voltage (V_{pv}), (ii) output current (I_{pv}). Related equations are given below

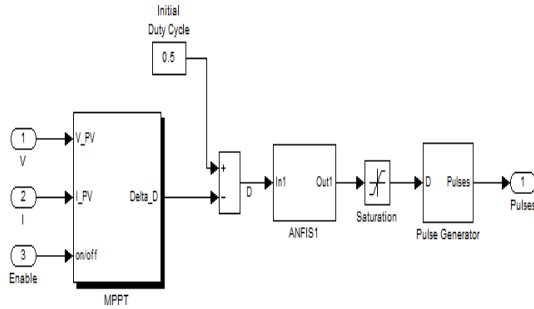

Fig. 2: Internal circuit of Boost Converter

MPPT BASED ANFIS CONROLLER

The incremental conductance method is modeled with ANFIS controller in Mat lab / Simulink software. By varying the radiation and temperature train the ANFIS [7] use of MPPT using Mat lab/Simulink toolbox.

By varying the radiation and temperature in order to train the ANFIS [4] use of MPPT using Mat lab/Simulink toolbox ANFIS can be trained 100 epochs, the error tolerance set to 0.01 can be optimized by using back propagation technique. The training error and ANFIS structure have shown in bellow fig4 & fig 5.

There are three membership functions and nine rules are utilized as a part of ANFIS controller. The ANFIS membership functions appear in figs 6 and 7. The ANFIS factors are communicated by phonetic factors, for example, Low, medium, high, for each of the two factors. A lead in the run base can be indicated in the shape: If (e is high) and (de is high), at that point (output is high). We take rules based system. The administer base alters the duty cycle towards the PWM within the boost converter as per the adjustments role of the ANFIS. The standards can be set as desired. The quantities of guidelines are 9 for the three membership function elements of the error and the adjustment in error.

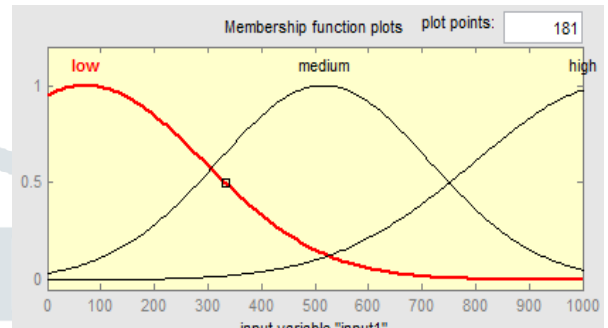

Fig.5: Error Membership functions

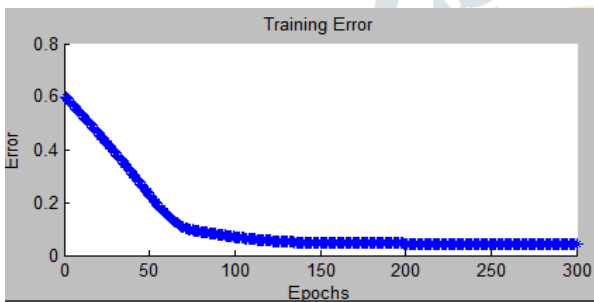

Fig.3: Training error versus epochs for the ANFIS.

The proposed ANFIS based MPPT works faster and simple compared to other MPPT techniques [5-7]. The nine rules of ANFIS editor has shown in below table 1.

Table1: Rules for ANFIS controller

$e/\Delta e$	Low	Medium	High
Low	Low	Medium	High
Medium	Medium	High	High
High	High	High	High

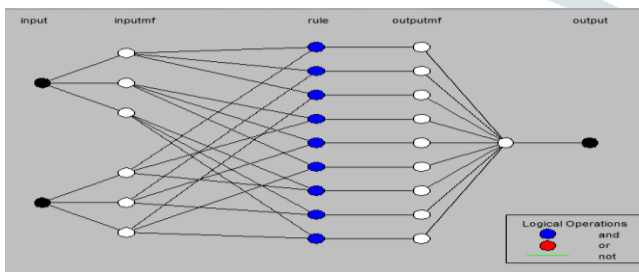

Fig.4: ANFIS-based MPPT structure

3. VOLTAGE SOURCE INVERTER

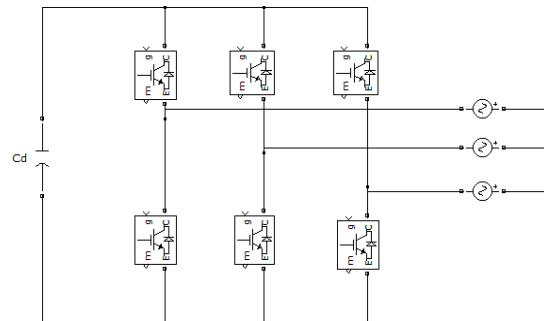

Fig 6: voltage source inverter

Voltage source converter has appeared in fig8. To convert the voltage DC-AC is used. Three phase inverter can be demonstrated as a six IGBTs. Three phase inverter is additionally being controlled utilizing ANFIS controller. LC filters are used to filter the out voltage of the inverter. fig2 shows the simulation diagram of the voltage source inverter with ANFIS controller.

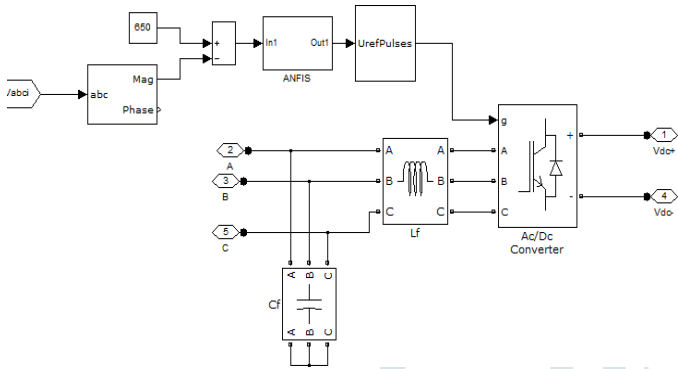

Fig.7. Simulation model of the VSI system

Simulation Control diagram of the three phase inverter has shown fig3. The measured output voltage is compared with reference voltage and the error is tuned by using ANFIS controller. The output of the ANFIS controller is given to the PWM to generate gating pulses to the three phase inverter.

4. PROPOSED SYSTEM

Fig1 demonstrates the outline of the grid associated PV frameworks. It is having Photovoltaic frameworks, DC to DC boost converter, and voltage source inverter, three phase load and grid. DC to DC boost converter [8] and voltage source converter interfacing in the middle of load and PV module. Maximum power point technique [9] is utilized to tracks the most extreme power from the PV module when the radiation and temperature are changes rapidly. MPPT procedure is utilized to modify the duty cycle and control the boost converter to keep up the most extreme power from the PV module. Furthermore, modify the adjustment modulation index of the VSI [10] to change over DC voltage to AC voltage.

The input –output voltage of DC to DC boost converter is

$$(2)$$

Where,

'D' is the duty cycle. The duty cycle is fluctuates in the middle of 0 to 1 then the output voltage higher than the input voltage. PV cluster is associated with DC to DC boost converter to expanding the duty cycle the PV current is builds then the pv voltage can be reduces. At that point the I-V qualities of the PV cluster are moving to left side. Additionally, the duty cycle is reducing the PV current reduces and the PV voltage increments. Incremental conductance strategy with ANFIS controller is utilized to keep up the steady DC voltage.

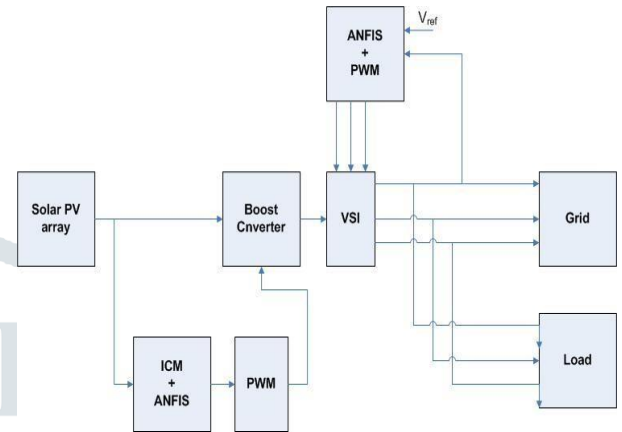

Fig.8: Block diagram of PV-GRID system

5. SIMULATION RESULTS

To evaluate the designed controller’s robustness, simulation is performed in the case as explained below

The above Fig.3 shows the integrated PV-GRID system. The solar irradiation of PV system is 1000 W/m² and the temperature is 25 °C. From PV system we are getting PV voltage of 260V. By using ANFIS controller the boost converter voltage is boosted to 520V shown in fig 6 (a) and (c) respectively. PV current of PV panel is 35A shown in fig6 (b). The I-V characteristic of PV system is shown in Fig 4. The P-V characteristic of PV system is shown in fig 5.

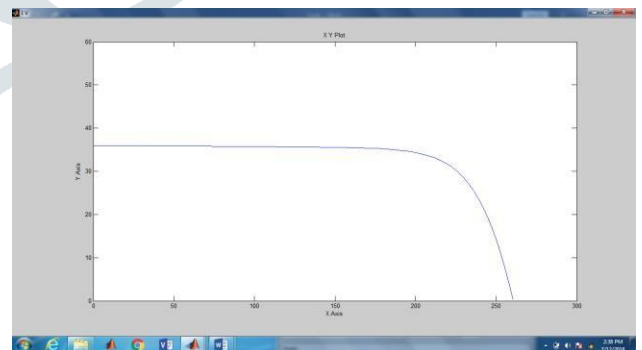

Fig.9: I-V Characteristics of PV System

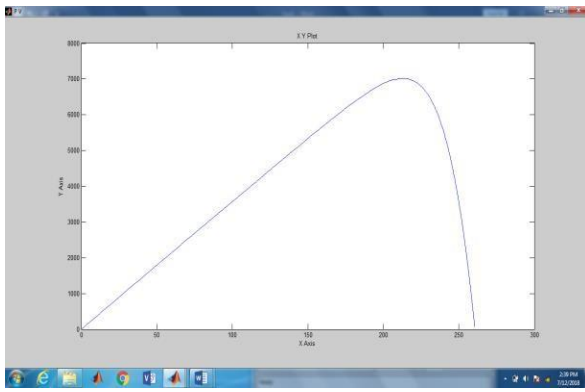

Fig.10: P-V Characteristics of PV System

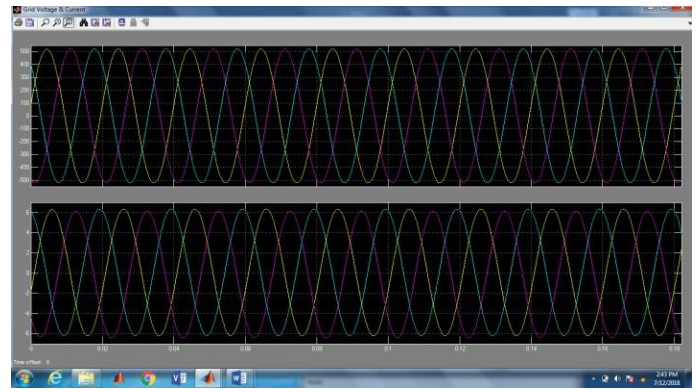

Fig:13 Grid Voltage and Current

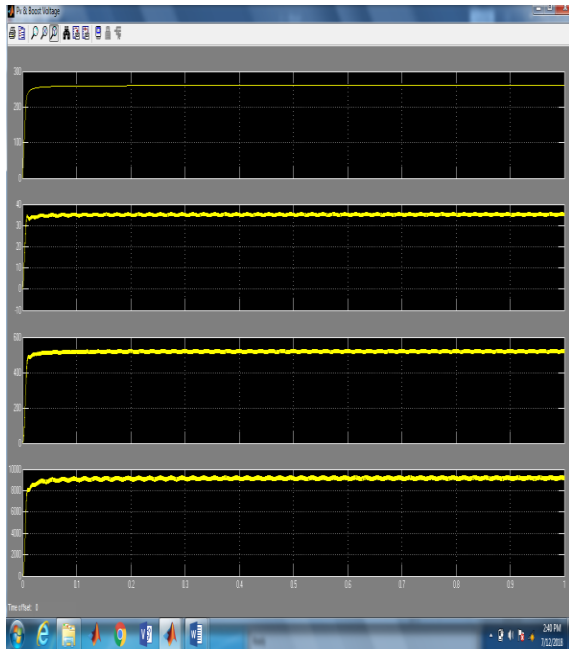

Fig:11 (a) PV voltage(volts), (b)PV current(Amps), (c)boost converter voltage(volts), (d)PV power(watts)



Fig:14 Grid Active Power and Reactive Power

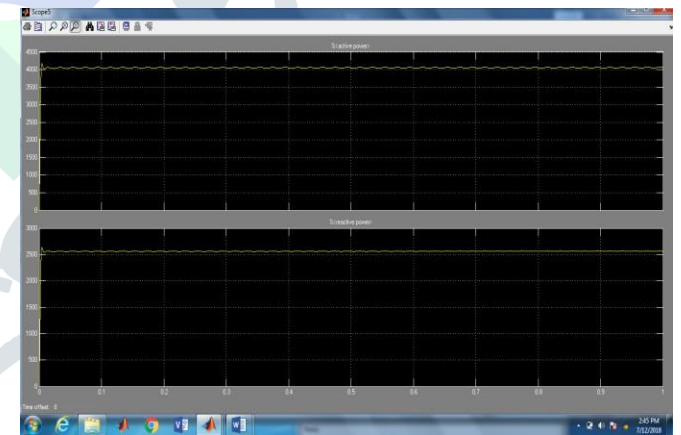

Fig:15 Load Active Power and Reactive Power

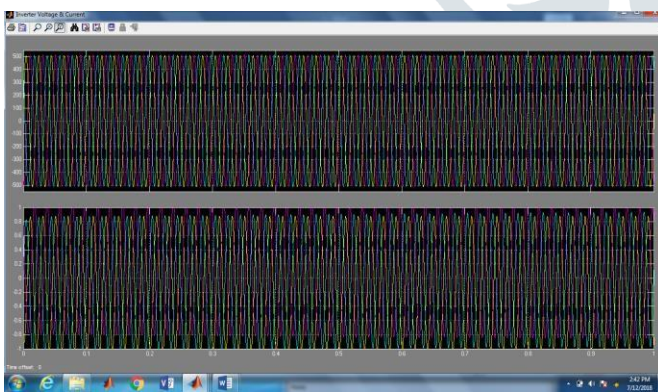

Fig:12 Inverter output voltage and current

The harmonic analysis is presented below

With out LC filter there are more harmonics in the system, by doing the FFT Analysis to the system. The Load Voltage and the Inverter Current harmonics can be seen as

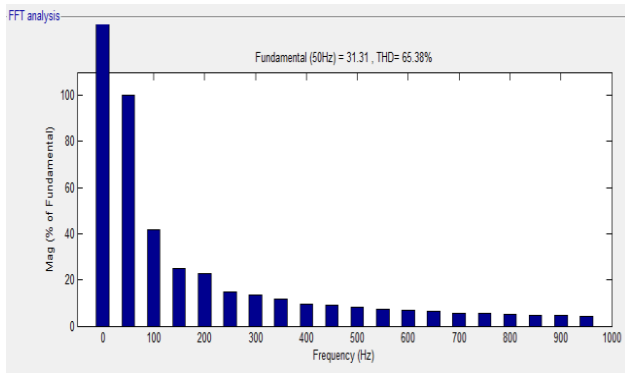

Fig.16: Load Voltage harmonic analysis

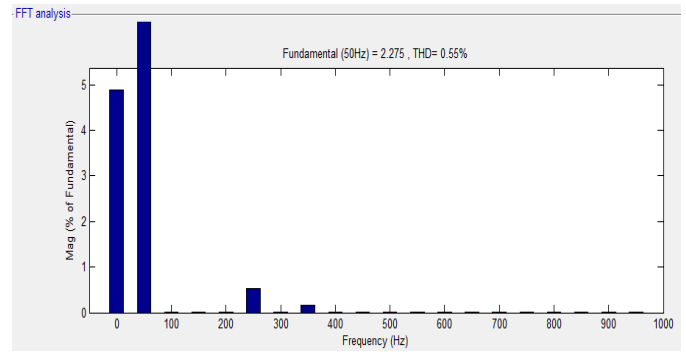

Fig.19: Grid Current harmonic analysis

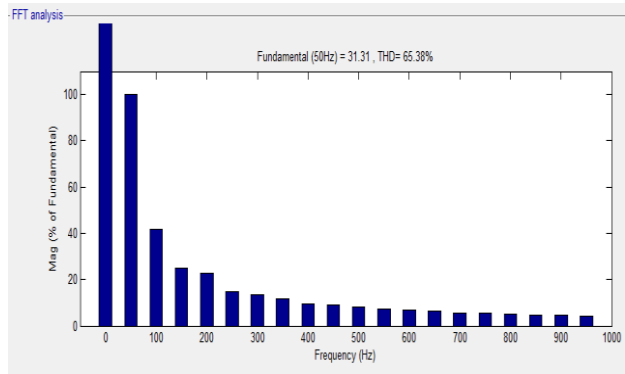

Fig.17: Inverter Current harmonic analysis

By seeing this, when the PV system is connected to the grid the harmonics more in the system. By using the Filters to the system, the harmonics will be suppressed and FFT analysis can be done to the whole system. In this way Power quality can be achieved.

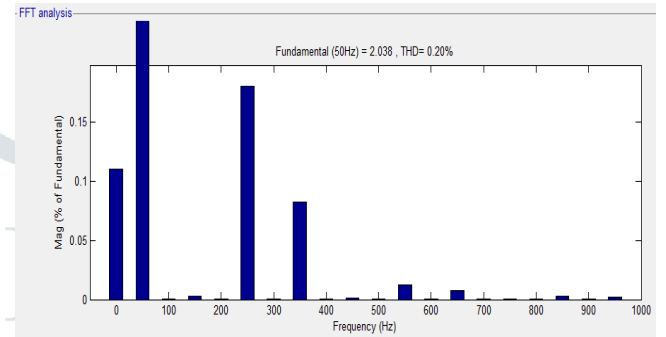

Fig.20: Load Current harmonic analysis

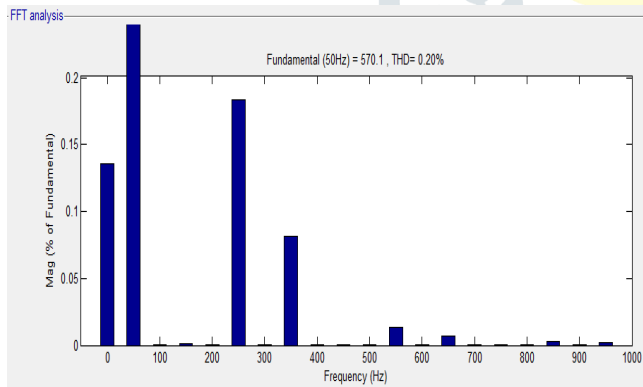

Fig.18: Inverter Current harmonic analysis

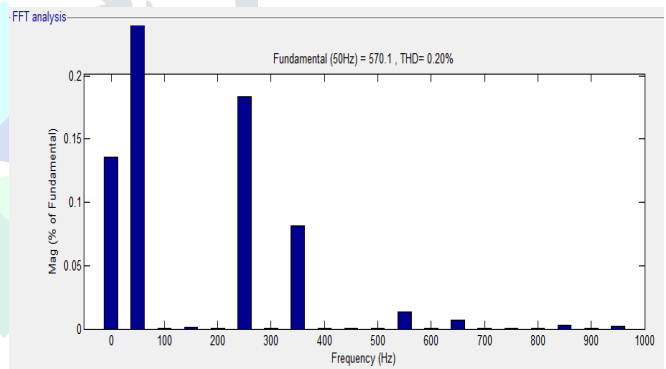

Fig.21: Inverter Voltage harmonic analysis

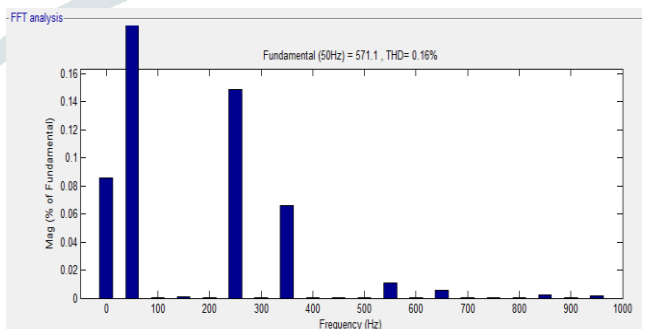

Fig.22: Grid Voltage harmonic analysis

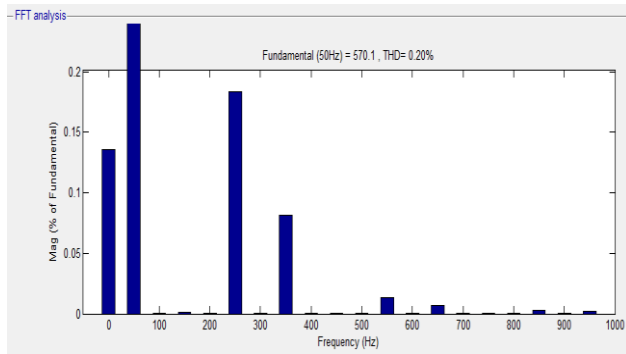

Fig.23: Load Voltage harmonic analysis

Table 2: THD values of PV-GRID system

Parameter	THD
Grid voltage	0.16%
Grid current	0.55%
Load voltage	0.20%
Load current	0.20%
Inverter Voltage	0.20%
Inverter Current	0.20%

6. CONCLUSION

This paper presents a PV-Grid system. In photovoltaic system, ANFIS based ICM MPPT controller used to control the boost converter output voltage. VSI connected boost converter and VSI is controlled by ANFIS. Maximum power is achieved from the ICM & ANFIS controller. The harmonics of the system studied with the FFT analysis. By using the filters, the harmonics are brought down to the prescribed limits. The whole system implemented in SIMULINK software and results are been studied.

REFERENCES

[1] Ahmed N.A.; Miyatake M. A Stand-alone Hybrid Generation System Combining Solar Photovoltaic and Wind Turbine with Simple Maximum Power Point Tracking Control, Power Electronics and Motion Control Conference, 2006. IPEMC2006. CES/IEEE 5th International Volume:1 DOI: 10.1109/IPEMC.2006.4777984, 2006, 1-7

[2] Shanthi, T., and A. S. Vanmukhil. "Photovoltaic generation system with MPPT control using ANFIS." *International Electrical Engineering Journal (IEEJ)* 4.3 (2013): 11.

[3] Chen, Guanrong, and Trung Tat Pham. *Introduction to fuzzy sets, fuzzy logic, and fuzzy control systems*. CRC press, 2000.

[4] Walker, Geoffrey R., and Paul C. Sernia. "Cascaded DC-DC converter connection of photovoltaic modules." *IEEE transactions on power electronics* 19.4 (2004): 1130-1139.

[5] Hohm, D. P., and M. E. Ropp. "Comparative study of maximum power point tracking algorithms." *Progress in photovoltaics: Research and Applications* 11.1 (2003): 47-62.

[6] Ho, Billy MT, Shu-Hung Chung, and S. Y. R. Hui. "An integrated inverter with maximum power tracking for grid-connected PV systems." *Applied Power Electronics Conference and Exposition, 2004. APEC'04. Nineteenth Annual IEEE. Vol. 3. IEEE, 2004.*

[7] Lee, Jae Ho, HyunSu Bae, and Bo Hyung Cho. "Advanced incremental conductance MPPT algorithm with a variable step size." *Power Electronics and Motion Control Conference, 2006. EPE-PEMC 2006. 12th International. IEEE, 2006.*

[8] Pavan Kumar Naidu, R, & S Meikandasivam. "ICM based ANFIS MPPT controller for grid connected photovoltaic system." *International Journal of Engineering & Technology [Online]*, 7.3 (2018): 1508-1513. Web. 18 Sep. 2018

[9] S.Supraja, R.Pavan Kumar Naidu. "A NOVEL ON SOLAR WIND HYBRID MODEL FOR EFFICIENCY IMPROVEMENT" by S.Supraja, *International Journal For Research in Applied Science & Engineering Technology (IJRASET : 2321-9653)*, Volume-5, Issue IX, September-2017 Pages: 1907 to 1918. (UGC approved Journal).

[10] S.Supraja, R.Pavan Kumar Naidu "A NOVEL ON SOFT COMPUTING TECHNIQUES FOR EFFICIENCY IMPROVEMENT IN PV", by S.Supraja, *International Journal For Research and Development in Technology (IJRDT-ISSN(O): 2349-3585)*, Volume-7, Issue.4, April-17 Pages: 483 to 487.