

COMPARATIVE STUDY OF ANALYSIS AND DESIGN OF PRE-ENGINEERED AND CONVENTIONAL INDUSTRIAL BUILDING BY USING SUITABLE SOFTWARE

¹Saurabh Dilip Pophali , ² Prof. Kunal R. Ghadge

¹P.G. Student Civil engineering ²Head of Department Civil Engineering Sanmati Engineering College Washim

¹Department of Civil Engineering

¹Sanmati Engineering College Washim , India

Abstract: In this mini project a boiler shed is analyzed and designed. The shed is designed in two ways. Firstly conventional truss is used and it is designed. Then using tapering sections (Pre-engineer) boiler shed is designed. Analysis of both type of shed is done by STAAD Pro. The steel boiler shed design is as per the clauses and norms specified by IS 800-1984, IS: 875-Part I, IS: 875-Part II, IS: 875-Part III. Designing is done using various load combinations. Designing is done in 2D as well as 3D. A scaled model of the 2D and 3D conventional truss as well as pre-engineered buildings was prepared.

Purpose of this project is to understand the design of pre-engineered buildings as well as to study the advantages of conventional structures over pre-engineered building. The obtained numerical results are used to study of advantages of conventional structures over pre-engineered buildings. The variations in some of the results may be attributed to practical limitations of designing procedures.

The validated software models are further used in parametric study includes determination of weight of the members. The weight of members can be used to determine the cost of building of conventional as well as pre-engineered buildings. This parameter can also be used to determine the requirement of material and accordingly cost can be determined.

IndexTerms – Pre-Engineered, conventional, staadpro, design.

I. INTRODUCTION

"Pre-engineered steel buildings" are those which are fully fabricated in the factory after designing, manufactured and shipped to site in CKD (completely knocked down) condition; and all components are assembled and erected at site with nut-bolts, thereby reducing the time of completion"

Technological improvement over the years has contributed immensely to the enhancement of quality of life through various new products and services. One such revolution was the pre-engineered buildings. Through its origin can be traced back to 1960's its potential has been felt only during the recent years. This was mainly due to the development in technology, which helped in computerizing the design and design. A recent survey by the Metal Building Manufacturers Associations (MBMA) shows that about 60% of the non-residential low rises building in USA are pre-engineered buildings.

Although PEB systems are extensively used in industrial and many other non-residential constructions worldwide, it is relatively a new concept in India. These concepts were introduced to the Indian markets lately in the late 1990's with the opening up of the economy and a number of multi nationals setting up their projects. The market potential of PEB's is 1.2 million tons per annum. The current pre-engineered steel building manufacturing capacity is 0.35 million tons per annum. The industry is growing at the compound rate of 25 to 30 %. Pre-engineered buildings are generally low rise buildings; however the maximum eave heights can go up to 25 to 30 meters. Low rise buildings are ideal for offices, houses, showrooms, shop fronts etc. The application of pre-engineered concept to low rise buildings is very economical and speedy. Buildings can be constructed in less than half the normal time especially when compared with other engineered sub-systems.

II. METHODOLOGY

In this mini project a boiler shed is analyzed and designed. The shed is designed in two ways. Firstly conventional truss is used and it is designed. Then using tapering sections (Pre-engineered) boiler shed is designed. Analysis of both type of shed is done by STAAD Pro . The steel boiler shed design is as per the clauses and norms specified by IS 800-1984, IS: 875- Part I, IS: 875-Part II, IS: 875-Part III. Designing is done using various load combinations. Designing is done in 2D as well as 3D. A scaled model of the 2D and 3D conventional truss as well as pre-engineered buildings was prepared.

ANALYSIS AND DESIGN OF PRE ENGINEERED AND CONVENTIONAL INDUSTRIAL BUILDING

Proposed industrial structural steel building of boiler shed for Forbes Marshall located at Chakan, Pune.

Table 1: Building Description

1	Type of building	Industrial building
2	Type of structure	Single storey industrial building
3	Location	Pune
4	Type of truss	Belgian Truss
5	Area of building	960 m ²
6	Roof slope(PEB)	5.71°
7	Roof slope(CSB)	16.7°
8	Width(m)	20.0 m c/c of steel column
9	Length(m)	48.0 m c/c steel columns
10	Eave height	8.7 m
11	Support Condition (CSB)	Pinned
12	Support Condition (PEB)	Pinned
13	Number of bays	6
14	Single bay length	8 m
15	Spacing of purlin	1.5 m
16	Spacing of girts	1.5 m
17	Rise of Truss	3 m

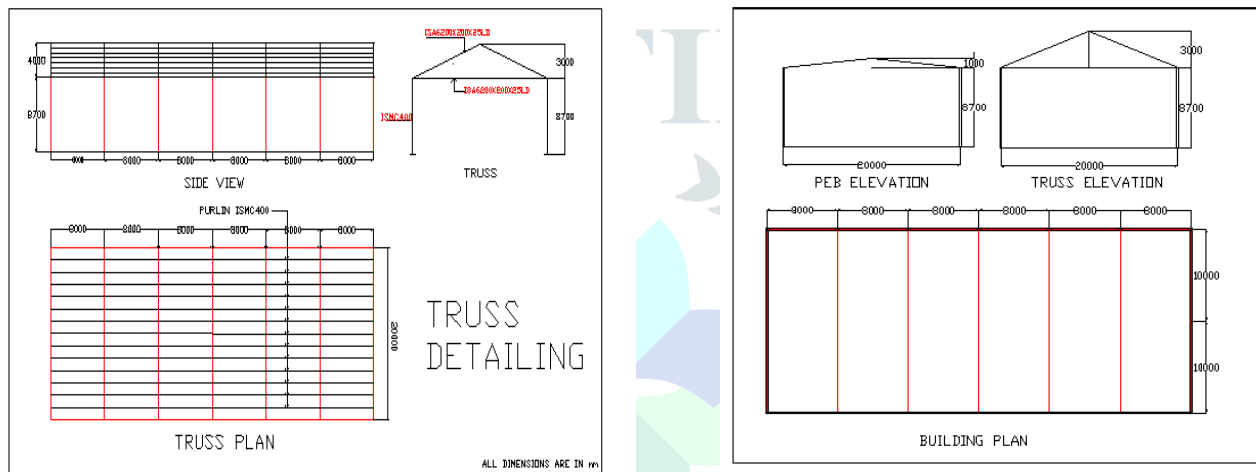

LOADING CALCULATIONS ON FRAMES, PURLINS AND GIRTS

Dead Load Calculations on conventional steel building and pre-engineered building

Self-Wt of Frame = As calculated by STAAD

Weight of GI sheeting = 0.131 kN/m²

Weight of fixings = 0.025 kN/m²

Weight of services = 0.1 kN/m²

Total Weight = 0.131 + 0.025 + 0.1
= 0.256 kN/m²

Total weight on purlin = 0.256 x 1.5
= 0.384 KN/m

Total weight on girt = 0.256 x 1.5
= 0.384 KN/m = 0.4 KN/m

Self wt of purlin = 0.318 kN/m²

Dead Load on Frame = (0.318 + 0.256) x (8 x 1.44)
= 6.61 KN

Live Load on Conventional Steel Building

Live load on the sloping roof = 750 - 20(α - 10)

Where α = 16.8°

= 750 - 20(16.8 - 10)
= 0.614 KN/m²

Live load on purlins = 0.614 x 1.5 = 0.921kN/m

Live load on frame = 0.614 x 8 x 1.44 = 7 KN

Live Load on Pre-Engineered Building

Live load on the sloping roof = 0.75 (Angle less than 10°)

Live load on purlins = 0.75 × 1.5 = 1.125kN/m

Live load on frame = 0.75 x 8 = 6 KN/m

Wind Load Calculations for Conventional Steel Building and Pre-Engineered Building

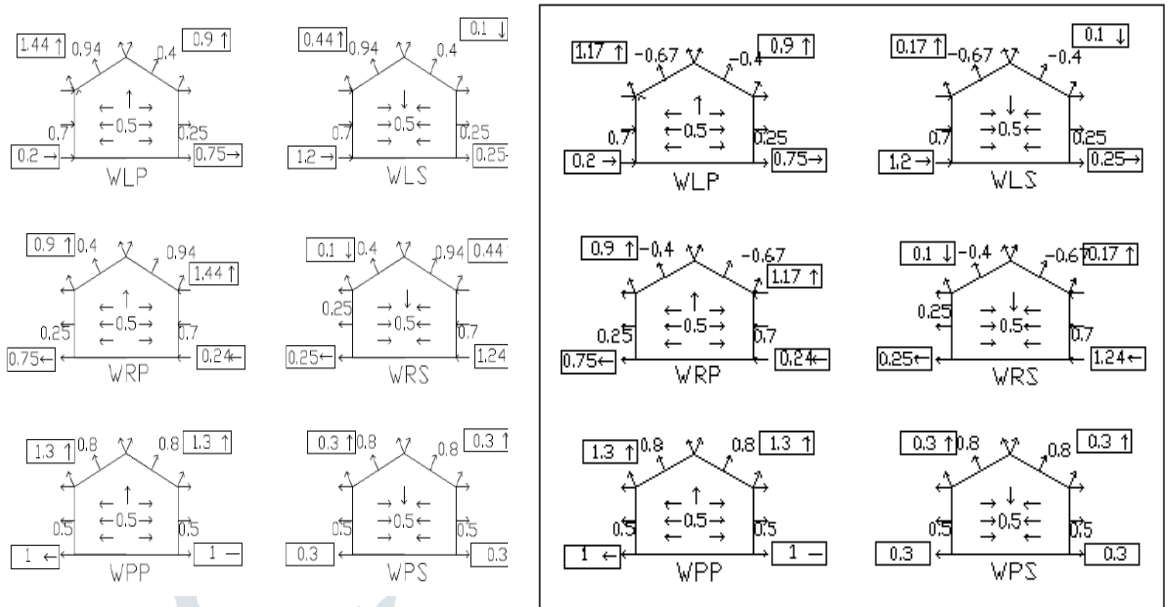

Figure 1: Wind Load Diagram of PEB & CSB

$$F = (Cpe - Cpi) \times A \times Pz$$

Where, Cpe – External Coefficient Cpi – Internal Coefficient

A – Surface Area in m² Pz – Design Wind Pressure in KN/m²

LOAD COMBINATIONS USED

LOAD COMBINATIONS AS PER IS800-1984

- DL= Dead load
- LL= Live load
- WL= Wind load

- 1) DL+LL
- 2) DL+LL+WLP
- 3) DL+LL+WLS
- 4) DL+LL+WRP
- 5) DL+LL+WRS
- 6) DL+LL+WPP
- 7) DL+LL+WPS
- 8) DL+WLP
- 9) DL+WLP
- 10) DL+WLP
- 11) DL+WLS
- 12) DL+WRP
- 13) DL+WRS
- 14) DL+WPP
- 15) DL+WPS

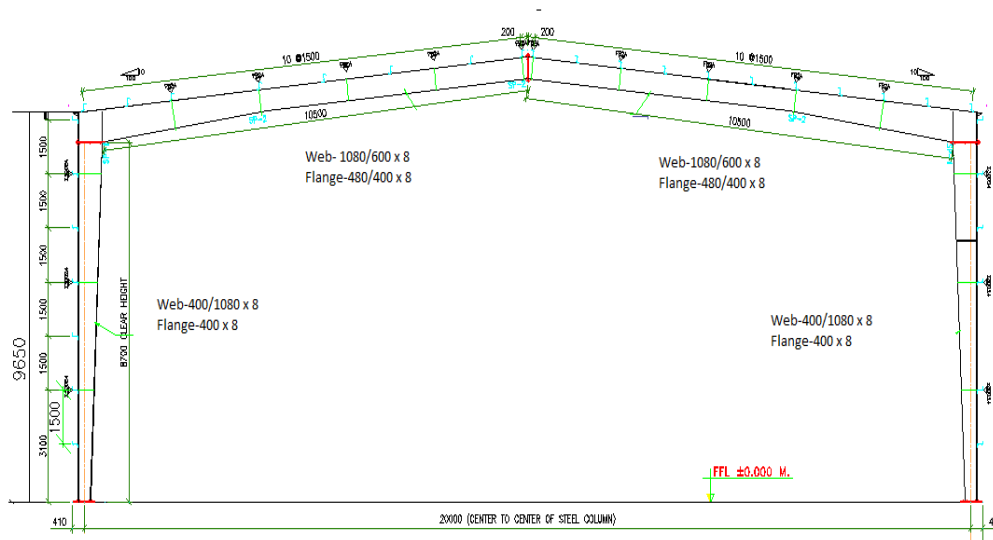

III. RESULT

Parameter	PEB	CSB
Weight of frame in 2D	13.386 KN	18.255 KN
Weight of frame in 3D	309.686 KN	446.053 KN

IV. CONCLUSION

- Pre-engineered buildings are on the average 30% lighter through the efficient use of steel.
- Price per square meter may be much as 22% lower than conventional steel.
- In PEB, Depth of sections is required or provide as per the bending moment occurred along the section.
- Pre Engineered building construction is much more economical and better solution for long span structures where large column free areas are needed

REFERANCES

- [1] Bureau Of Indian Standards IS 875(PART 1 DEAD LOADS) : 1987, "Code of Practice for Design Loads (Other than Earthquake) for Building And Structures"
- [2] Bureau Of Indian Standards IS 875(PART 1 DEAD LOADS) : 1987, "Code of Practice for Design Loads (Other than Earthquake) for Building And Structures".
- [3] Bureau Of Indian Standards IS 875(PART 2 IMPOSED LOADS) : 1987, "Code of Practice for Design Loads (Other than Earthquake) for Building And Structures"
- [4] Bureau Of Indian Standards IS 875(PART 3 WIND LOADS) : 1987, "Code of Practice for Design Loads (Other than Earthquake) for Building And Structures"
- [5] C.M.Meera "Pre-Engineered Building Design of an Industrial Warehouse" 2013
- [6] S.K.Duggal (2013) "Design of steel structure"