

MIMO COMMUNICATION

IRAM NAUSHEEN¹ AFREEN KHAN² RUZAINA SOHAIL³, ASHWINI DHANDOLE⁴, SONALI MADAVI⁵

¹Asstt. Professor, ²⁻⁵M.Tech Student,

¹⁻⁵ANJUMAN COLLEGE OF ENGINEERING & TECHNOLOGY

Abstract : MIMO (multiple inputs, multiple outputs) is an antenna technology for wireless communications in which multiple antennas are used at both the source (transmitter) and the destination (receiver). The antennas at each end of the communications circuit are combined to minimize errors and optimize data speed. Entire sub streams are transmitted in the same frequency band. It has efficient spectrally efficiency. Total radiated power is held constant irrespective of the number of transmitting antennas. The combined use of transmit and receive arrays improve the data rate. With BLAST downloading a song would Take 3 sec only.

Key Words: Narrowband MIMO model, MIMO channel capacity, MIMO diversity gain, space time modulation & coding.

I. INTRODUCTION

MIMO: Introduction

MIMO is usually derived by combining SIMO or Single Input Multiple Output, SISO or Single Input Single Output and MISO or Multiple Input and Single Output standards. The access point in MIMO helps in transmitting wireless signals over multiple antennae; thereby, increasing the strength and effectiveness of

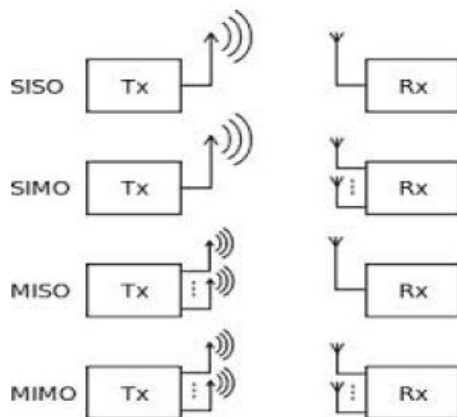

the signal.

Multiple-input multiple-output or MIMO is a radio communications technology which is basically a communication channel with multiple transmitters and receivers of an antenna so as to improve the overall performance of the system. MIMO attains space measurements to enhance the capacity of a wireless system, its range and also reliability. It provides higher data throughput and link range without the requirement of any additional bandwidth or transmitting power. MIMO has been around for many years but using it in wireless system is a newer phenomenon.

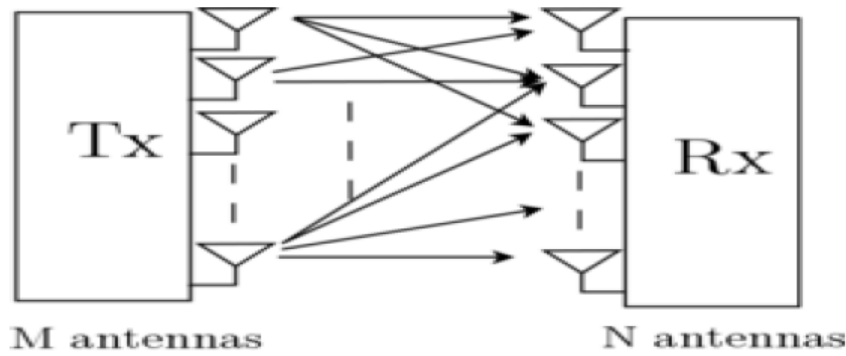

Fig-1: Schematic of a wireless MIMO system

1.1 Narrowband MIMO model

Consider a narrowband MIMO channel in this section. A narrowband also known as a flat fading point to point communication system which employs n transmit and m receive antennas as shown in figure 1.1.

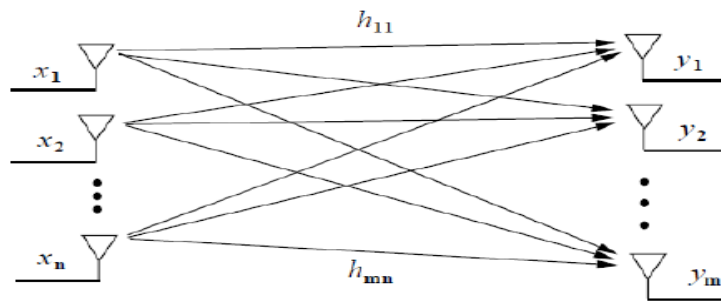

Fig 1.1 : MIMO systems

This system can be represented by the discrete time model as follows:

$$\begin{bmatrix} y_1 \\ \vdots \\ y_m \end{bmatrix} = \begin{bmatrix} h_{11} & \dots & h_{1n} \\ \vdots & \ddots & \vdots \\ h_{m1} & \dots & h_{mn} \end{bmatrix} \begin{bmatrix} x_1 \\ \vdots \\ x_n \end{bmatrix} + \begin{bmatrix} N_1 \\ \vdots \\ N_m \end{bmatrix}$$

Or a simple representation could be $\tilde{y} = Hx + \tilde{N}$

x = n-dimensional transmitted symbol

\tilde{N} = m-dimensional AWGN vector

H = channel matrix

The H-matrix consists of zero Rayleigh fading complex circular random variables h_{ij} representing the channel gain from transmit gain j and antenna gain i. We normalize the noise without the loss of generality so that the covariance matrix of noise is an identity matrix. Note that x y N and H used here are all stochastic processes. Consider that the receiver is able to estimate every value of H perfectly so that each value of H is known at the receiver. The transmit power is constrained by:

$$\sum_{i=1}^n \mathbf{E}[x_i x_i^*] = P,$$

Or equivalently given by:

$$\text{trace}(\mathbf{E}[\overline{x x^\dagger}]) = P.$$

1.2. MIMO channel capacity

The MIMO decomposition mentioned above permits a simple description of the MIMO channel capacity when the transmitter and receiver both has the complete knowledge of H. The capacity formula is given by:

$$C = \max_{Q: \text{Tr}(Q) \leq P} \log |I + H Q H^\dagger|,$$

Where the maximum is considered the overall matrices Q, which satisfies the constrained average power. Substitution of SVD matrix and the properties of unitary matrices in the above equation gives:

$$C = \max_{\{P_i\}: \sum_i P_i \leq P} \sum_i B \log \left(1 + \frac{\lambda_i^2 P_i}{N_0 B} \right),$$

which is equivalent to flat fading or in frequency selective fading having constant channel gains. Thus a similar water-filling power allocation for the MIMO channel is thus obtained having the eigen values:

$$\frac{P_i}{P} = \begin{cases} \frac{1}{\gamma_0} - \frac{1}{\gamma_i} & \gamma_i \geq \gamma_0 \\ 0 & \gamma_i < \gamma_0 \end{cases}$$

For some cutoff values $\gamma_0 = \lambda_1^{-2} P / (N_0 B)$. Thus the channel capacity is given by:

$$C = \sum_{i=1}^{(\gamma_i \geq \gamma_0)} B \log(\gamma_i / \gamma_0).$$

1.3 MIMO Diversity gain

MIMO diversity gain is classified into the following categories:

- 1) Beam forming
- 2) Diversity-multiplexing trade-offs

1.3.1 Beam forming

A transmit approach in which the co-variance matrix has a unit rank then it is called as beam forming. Figure illustrates the configuration of a MIMO channel with beam forming.

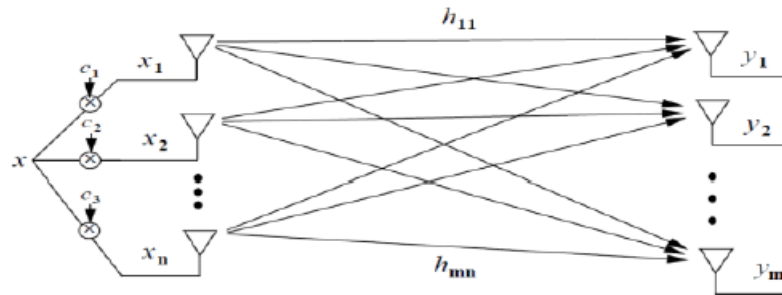

Fig-1.3.1: MIMO channel with beam forming

1.3.2 Diversity-multiplexing trade-offs

The diversity-multiplexing trade-off $d^*(r)$ of a MIMO channel is undoubtedly the ultimate possible diversity multiplexing –tradeoff attainable by any scheme.

R^*_{max} = maximum multiplexing gain reachable in a channel

$D^*_{max} = d^*(0)$ is the maximum gain attainable

For a $m \times n$ MIMO channel, it can be easily shown that:

$$r^*_{max} = \min\{m, n\}$$

$$d^*_{max} = mn$$

Figures illustrated below shows a 1×1 channel, 2×1 channel and 2×2 channel characteristics based on spatial multiplexing gain and diversity gain respectively.

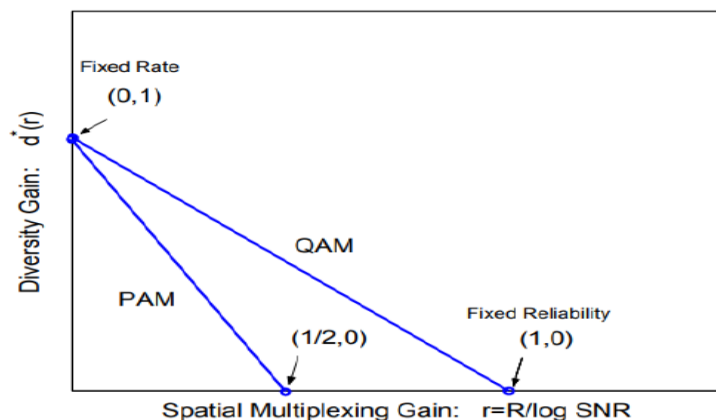

Figure 1.3.2.1: Example of 1×1 channel

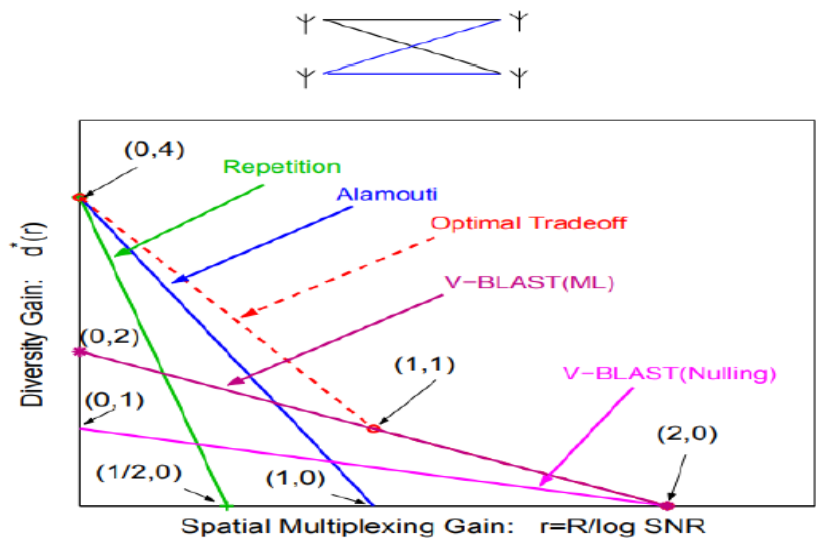
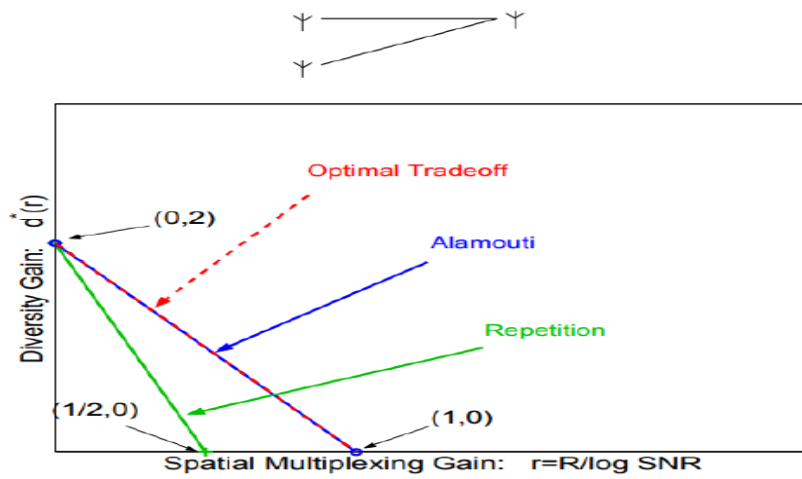

Fig-1.3.2.2: Example of 2 × 1 channel

Figure 1.3.2.3: Example of 2 × 2 channel

1.4 Space time modulation and coding

In this article , our major concentration will be on Space time block code (STBC),space time trellis coding(STTC), spatial multiplexing and Blast architectures.

1.4.1 Space -time block code (STBC)

MIMO systems makes use of space-time block codes to allow the transmission of many number of copies of an information stream over a number of antennas and to utilize the multiple received data units to enhance the capability of data transfer. Space time coding helps to combat major problems like fading and thermal noise because of the use of number of copies of data. In the space time block coding scheme, the stream of data is encoded in the form of blocks before the transmission takes place.

These blocks of data are segregated over multiple antennas and spacing in time domain is also done. The general representation method used for representing space time block code is by a matrix as shown below:

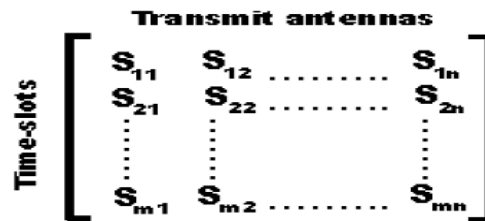

Fig 1.4.1: Space-time block code matrix representation

Time slot is represented by each row and one antenna's transmission in time domain is represented by each column.

1.4.2 Space-time trellis code (STTC)

Space-time trellis codes make use of a scheme in which the transmission of redundant copies of data is done in both time and space by making use of multiple numbers of antennas. These copies of the redundant data sets are utilized by the receiver to recover the original transmitted data.

Space-time trellis codes are able to give coding and diversity gain along with improved bit error rate performance. Complexity of encoding and decoding increases as it makes the use of trellis codes.

1.4.3 BLAST Architectures

Bell Labs Layered Space Time (BLAST) architectures are a family of architectures which came into view for systems which employ multiple antenna arrays at both the transmitter and receiver end.

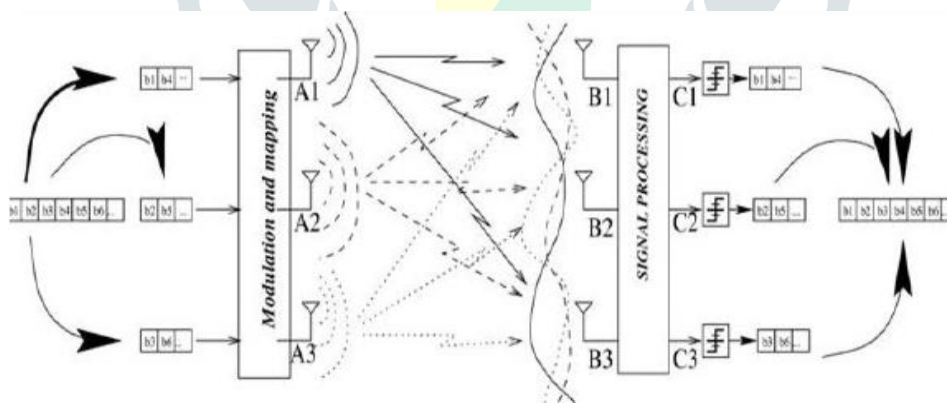

Fig 1.4.4: BLAST architecture

In this article, we only consider the overview of the various BLAST architectures. The BLAST architectures are categorized into three types:

- 1) D-BLAST architecture
- 2) V-BLAST architecture
- 3) Turbo BLAST architecture

1.4.3.1 D-BLAST Architecture:

It is the original scheme of BLAST architecture family with diagonally layered architecture i.e. it uses diagonally layered coding sequence. The layered design of D-BLAST architecture has number of layers equal to the number of antennas in which each layer is coded independently.

The major advantage of the D-BLAST architecture is that it fully utilizes the spatial and time diversity. Due to full utilization of spatial and time diversity it requires multiple numbers of decoders which introduces the drawback of complexity.

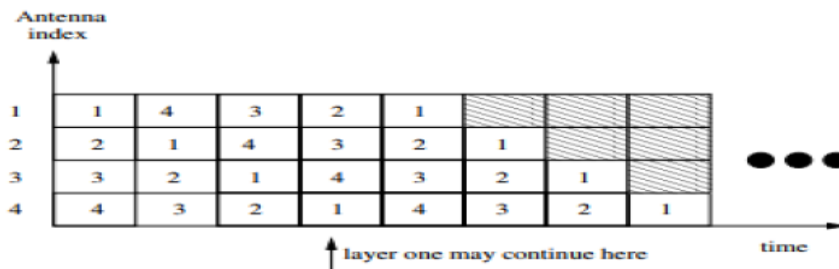

Fig 1.4.4.1: D-BLAST layer diagram

1.4.3.2 V-BLAST Architecture

The Vertical BLAST architecture is a much simpler architecture as compared to the D-BLAST architecture with reduced computational complexity which in turn lowers its transmit diversity.

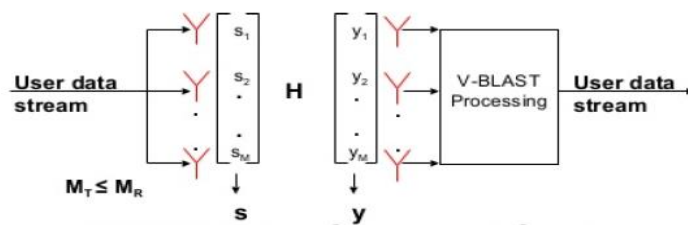

Fig 1.4.4.2: V-BLAST architecture

1.4.3.3 Turbo BLAST Architecture

Another BLAST architecture proposed by Sellathurai and Haykin based on the turbo principle which was later generalized by the Threaded Space-time architecture (STS) by Hammons and ElGamal.

The Turbo BLAST architecture uses random layered space-time coding scheme (RLST) before transmission at the encoder. The encoder & decoder of turbo BLAST architecture is shown in the below mentioned figures respectively.

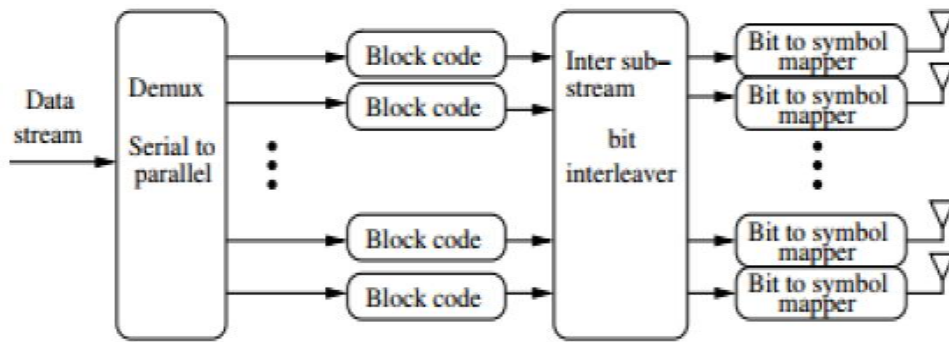

Fig 1.4.4.3.1: Encoder of Turbo BLAST architecture

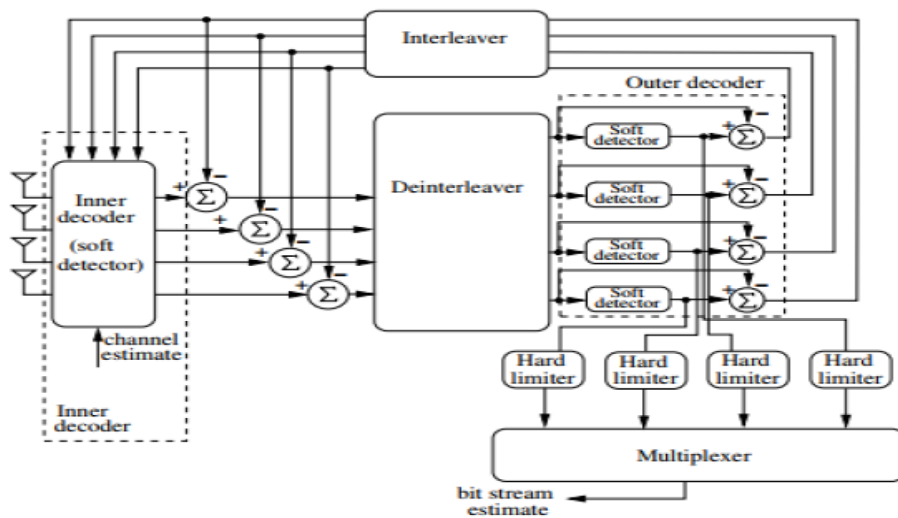

Fig 1.4.4.3.2: Decoder of Turbo BLAST architecture

2. CONCLUSIONS

MIMO communications is a much widely used concept in the field of wireless communications nowadays. Various technologies such as LTE & Wi-Fi are the fastest growing technologies in MIMO wireless communications. Parallel decomposition of MIMO channel, its diversity gain and various BLAST architectures for MIMO communications. The concept of spatial multiplexing can also be used to increase the spectral efficiency of the MIMO wireless communication systems. The major concepts of MIMO communication in wireless networks are aforementioned.

REFERENCES

- [1] www.cs.ucdavis.edu/~liu/289I/Material/book-goldsmith.pdf
- [2] <https://www.slideshare.net/onecolorheart/mimo-27833829>
- [3] <http://www.radio-electronics.com/info/antennas/mimo/precoding-codes-alamouti-diversity-space-time.ph>
- [4] https://en.wikipedia.org/wiki/Space%E2%80%93time_trellis_code.
- [5] <http://avalanwireless.com/>
- [6] Foschini, G.J.: Layered space time architecture for wireless communication in a fading environment when using multiple antennas. BellLabs Syst. Technol.
- [7] Zhang, H.; Wang, Z.; Yu, J.; Huang, J.: A compact MIMO antenna for wireless communication.
- [8] NiveditaChourasia and SopanKhadkodkar, MIMO Communication Study and Relay Diversity Analysis in Wireless Communication, International Journal of Electronics and Communication Engineering and Technology
- [9] Larsson, E.; Edfors, O.; Tufvesson, F.; Marzetta, T. Massive MIMO for next generation wireless Systems. IEEE Commun. Mag.
- [10] Marzetta, T.L. Massive MIMO: An Introduction. Bell Labs Tech. J. 2015
- [11] Wang, C.X.; Hong, X.; Ge, X.; Cheng, X.; Zhang, G.; Thompson, J. Cooperative MIMO channel models: A survey. IEEE Commun. Mag. 2010, 48, doi:10.1109/MCOM.2010.5402668.
- [12] Marzetta, T.L.; Caire, G.; Debbah, M.; Chih-Lin, I.; Mohammed, S.K. Special issue on massive MIMO. J. Commun. Netw.