

# Smart Meter: Pay first and then use it with theft detection

<sup>1</sup>Chetan Boghara, <sup>2</sup>Anish Vora,

<sup>1</sup>M.E.(Power System)

<sup>1</sup> B.H.Gardi College of Engineering and Technology, Rajkot (Gujarat), India

**Abstract**—In this paper, the idea of a Prepaid energy meter using an AT89S52 microcontroller has been introduced. This concept provides a cost efficient manner of electricity billing. The major drawback of traditional billing system is power and energy theft. This drawback is reduced by using a prepaid energy meter which is based on the concept “Pay first and then use it”. Prepaid energy meter also reduces the error made by humans while taking readings. The prepaid energy meter uses a recharge card. The recharge is done by using a keypad and the meter is charged with the amount. According to the power consumption, the amount will be reduced. An LDR (light Dependant Resistor) circuit counts the amount of energy consumed and displays the remaining amount of energy on the LCD. A relay system has been used which shut down or disconnect the energy meter and load through supply mains when the recharge amount is depleted. A Message send to the consumer before the recharge amount reaches a minimum value.

**Key word**—AT89S52 microcontroller, relay ,GSM modem energy meter.

## 1. Introduction

The present traditional billing systems have many problems like problem of payment collection, energy thefts etc. due to which the traditional billing system is slow, costly and unreliable[1]. The present billing system has chances of error and it is also time or labour consuming. A paper suggests a design of digital energy meter for improved metering and billing system[2]. Poly-phase prepaid energy metering system has also been proposed and developed based on local prepayment and card reader[3]. Another paper suggests prepaid energy meter using a microcontroller from microchip technology PIC family, used due to low cost of microcontrollers[4]. So it is essential to develop a billing system which solves the problem of billing. In this paper we proposed and designed a prepaid energy meter using microcontrollers AT89S52. The reason for using these microcontrollers is its high performance, power efficiency or design flexibility etc. In this paper, a recharge card is used which is available in various ranges (i.e. Rs. 100, Rs. 150, Rs. 200 etc.) and the energy meter to which the no. of recharge units has to be loaded. Suppose a consumer buys a recharge card for Rs. 100 he/she can insert this amount through the keypad so that the prepaid energy meter will be activated. According to the power consumption the amount will be reduced. A circuit is used to count the amount of energy consumed and an LCD is used to display the meter readings. When the recharge card amount is nil the relay will automatically shut down the whole system. In this project we also have provision to give message to the consumer before the whole amount is depleted[5].

## 2. Prepaid energy meter

Prepaid energy meter is technique which is cost efficient and can reduce problems associated with billing and also reduces deployment of manpower for taking meter readings. Prepaid energy meter has many advantages both from suppliers as well as

### Why Prepayment – From supplier point of view?

- Keep customers on supply
- Pay before use
- No bill production
- No bill distribution
- No need to chase payments
- No further actions such as disconnections
- Customer responsible for disconnection
- Load and demand side management
- Limit load
- Time based

### Why Prepayment – From Customer point of view?

- Flexible payment solution
- >80% mobile phones used in India are prepaid
- Pay to suit your income status
- Show real cost of consumption and remain money
- Reduce consumption when income is tight make money last

- No bills
- No billing errors
- No socially undesired disconnections

**3. Power supply to the circuit diagram**

**Description**

The power supply unit is used to provide a constant 5V of DC supply from a 230V of AC supply. These 5V DC will acts as power to different standard circuits. It mainly uses 2 devices.

1. Bridge wave rectifier
2. Voltage regulator

The block diagram of power supply is as shown in fig. below

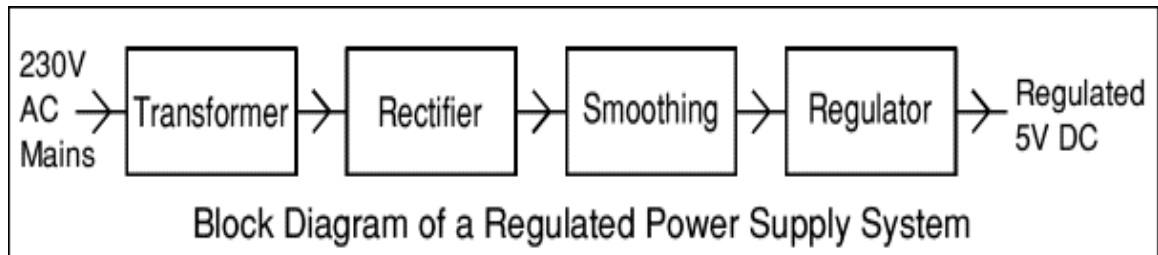

**1. Bridge wave rectifier**

A rectifier is an electrical device that converts alternating current to direct current, a process known as rectification. The term rectifier describes a diode that is being used to convert AC to DC. A bridge-wave rectifier converts the whole of the input waveform to one of constant polarity (positive or negative) at its output. Bridge-wave rectifier converts both polarities of the input waveform to DC direct current and is more efficient. However, in a circuit with a center tapped transformer is used.

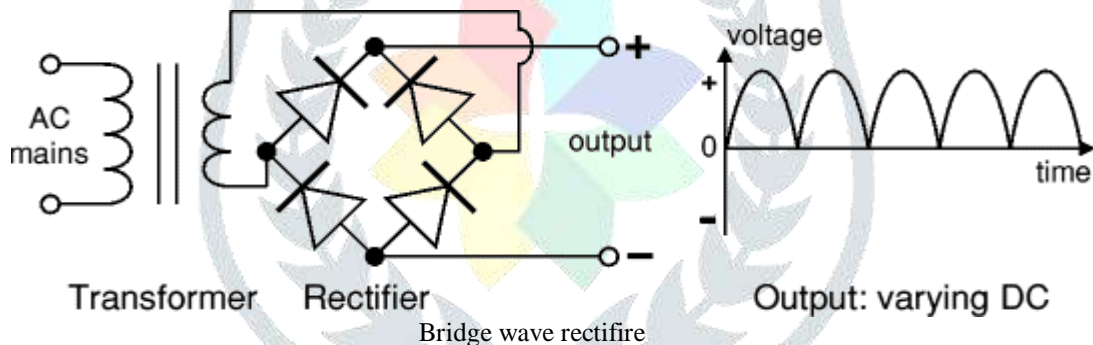

In this only two diodes are activated at a time i.e. D1 and D3 activate for positive cycle and D2 and D4 activates for negative half cycle. D2 and D4 convert negative cycle to positive cycle as it as negative supply and negative cycle as positive cycle at its output.

**2. Voltage Regulator**

This is most common voltage regulator that is still used in embedded designs. LM7805 voltage regulator is a linear regulator. With proper heat sink these LM78xx types can handle even more than 1A current. They also have Thermal overload protection, Short circuit protection[6].

This will connect at the output of rectifier to get constant Dc supply instead of ripple voltages

For some devices we require 12V/9V/4V Dc supply at that time we go for 7812/7809/7804 regulator instead of 7805 regulator. It also have same feature and pins has 7805 regulator except output is of 12V/9V/4V instead of 5V.

The general circuit diagram for total power supply to any embedded device is as shown below

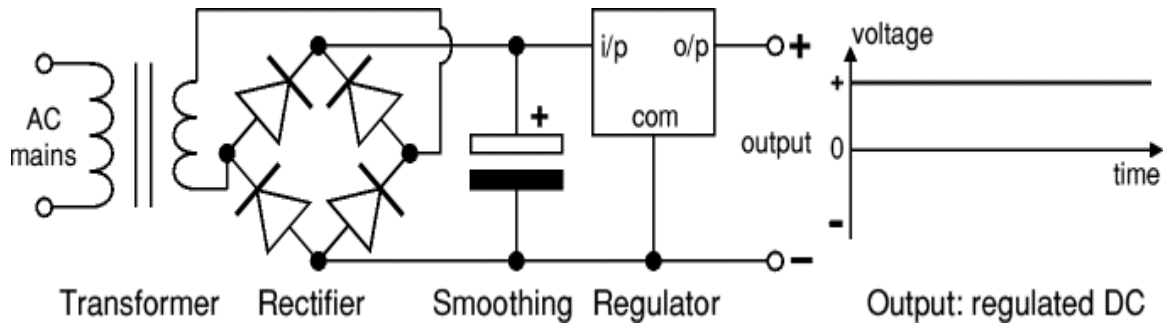

**4. Schematic Diagram and flow chart**  
**(A) Schematic Diagram**

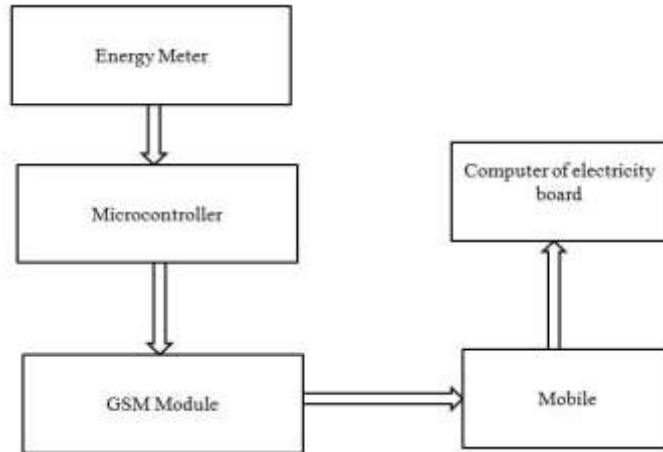

**Description of diagram**

**Energy Meter:**

The energy meter will read unit, and via calibration pin we have got pulse, Which we can give to the microcontroller

**Microcontroller**

We have design one program which will receive data serially from the IC (AT89s52) and will transmit it through AT command to the GSM module.

**GSM module**

The GSM module will send data to a particular mobile no. The data will be the unit which has been detected by energy meter.

**Mobile**

Mobile will receive data through sms. That will contain the unit of home/industry.

**Computer**

Computer will be having one program which will convert the unit into the amount of money (according to the prize of each unit). The program will be having graphical user interface which is very friendly environment to the user.

**(B) Flow chart**

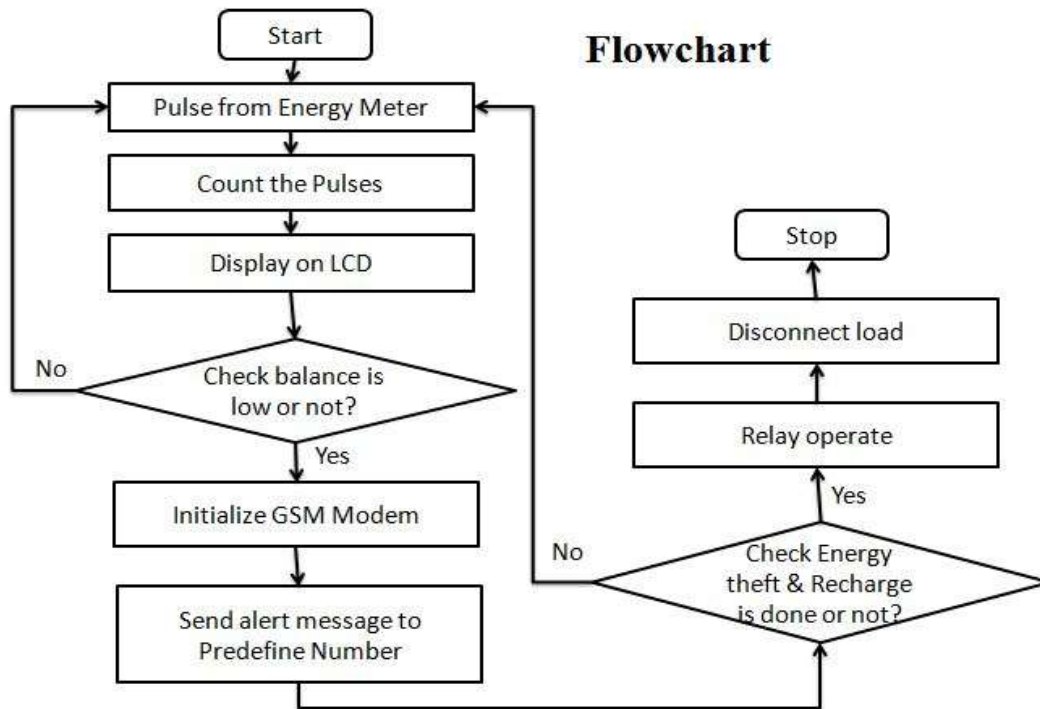

**Flowchart**

Above flow chart state that energy meter can generate the pulses and this generated pulses counted on LCD. This pulses is converted into watt and this watt displayed on LCD as per used by consumer or load. Then after controller check the balance if balance is higher than predefined rupees then no to worry but balance is low than predefined rupees than GSM operate and start to work and sending the alert message to the consumer about the recharge the energy meter balance.

Then after sending the alert message to the consumer about the recharge your prepaid energy meter checking the condition of the balance of the meter if balance is higher than not a problem but balance is low after sending alert message than completing this balance relay will operate and disconnect the load

Also checking energy theft detection with the balance of the energy meter if any consumer try to open the energy meter door and theft the energy than operate the relay and disconnect the load. After detecting the theft sending the message 'Theft Detected' to the energy provider company

**4. Simulation and Hardware Implementation**

**(A) Simulation and circuit diagram**

**Step 1**

As per the following figure lcd shows the available balance and usage unit as per required to load.D1 indicate single phase ac load and is now in running condition.This is the starting process when supply given to the circuit diagram.

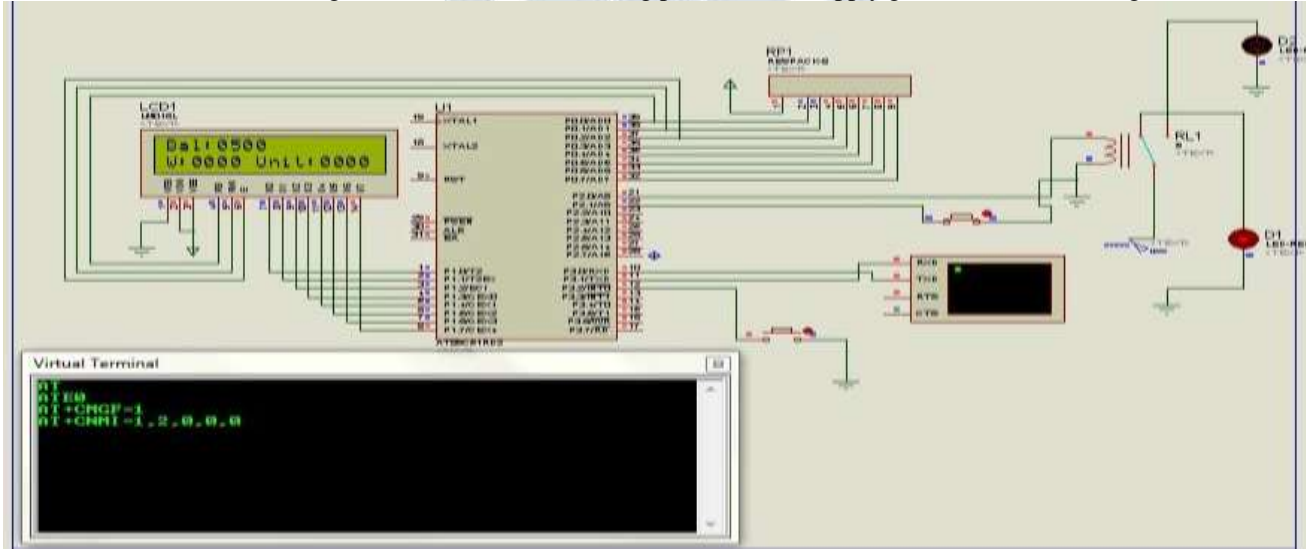

**Step 2**

Following figure indicate that when the balance was reduced due to energy usage as per load and then GSM modem send the message to the consume to recharge his energy meter for further use of the energy. In this figure D1 load indicated by led light in figure blink.

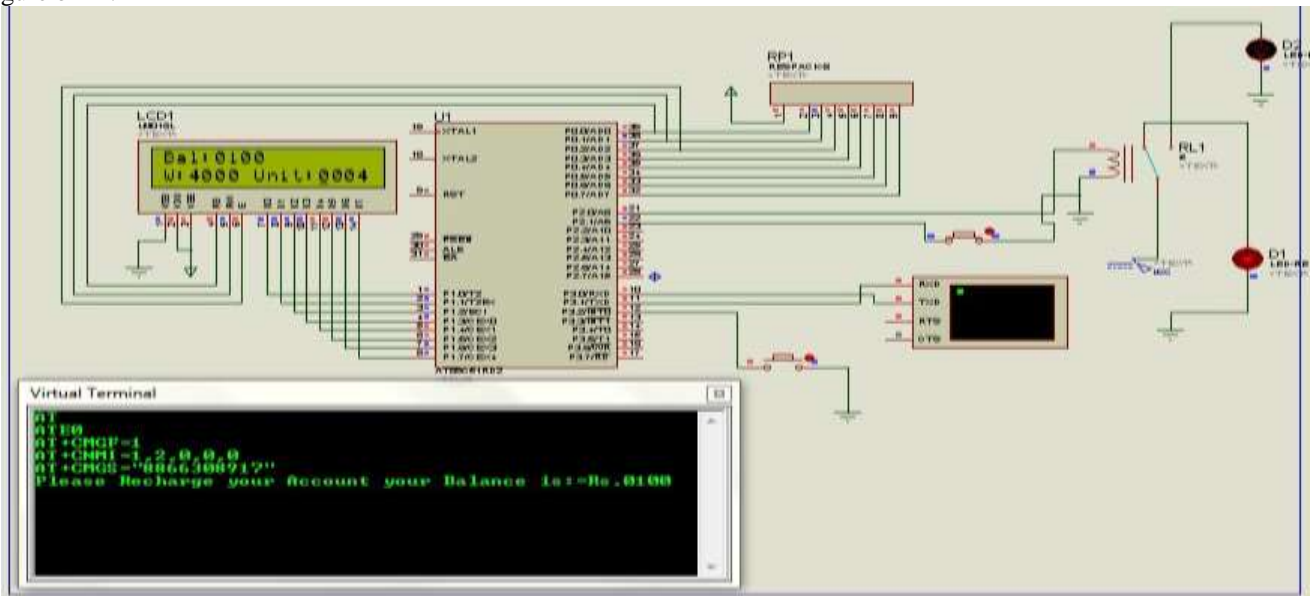

**Step 3**

After the alerting the message if customer will not recharge his energy meter balance then relay operated and disconnect the load. shown in the figure relay operated indicated by D2 led lamp blink and disconnected load is indicated by D1 led off.

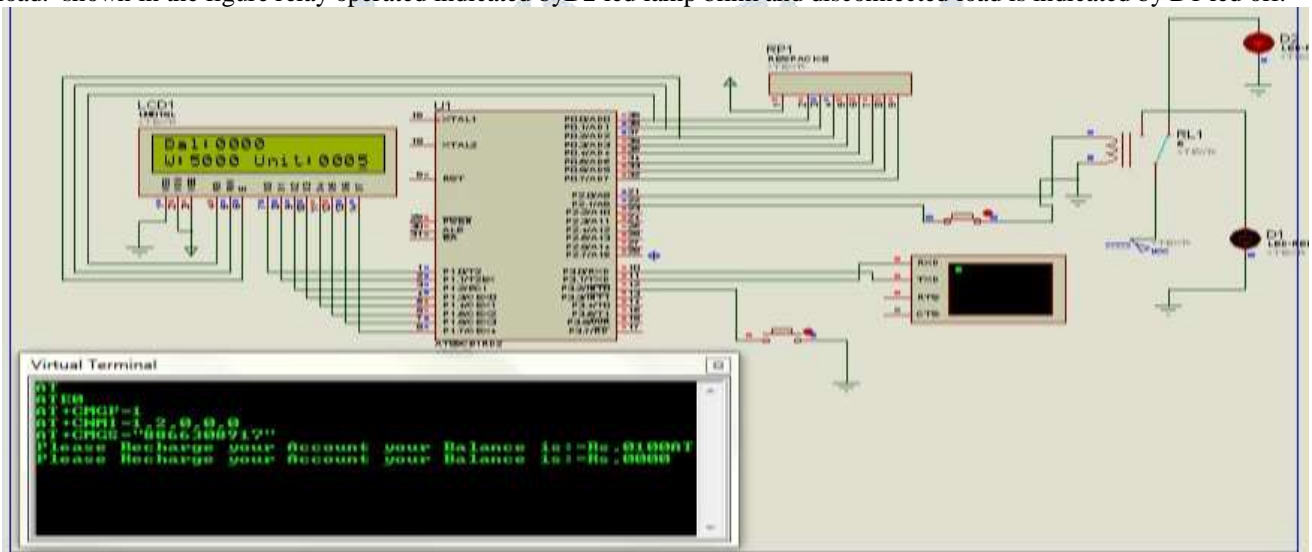

**Step 4**

From this figure if any consumer try to theft the energy by reversing the phase and neutral and this is possible only by opening the energy meter box because now a day there are energy meter box is provided by distributor company. If any consumer open this box then magnetic switch operated and sending the message to the distributor company.

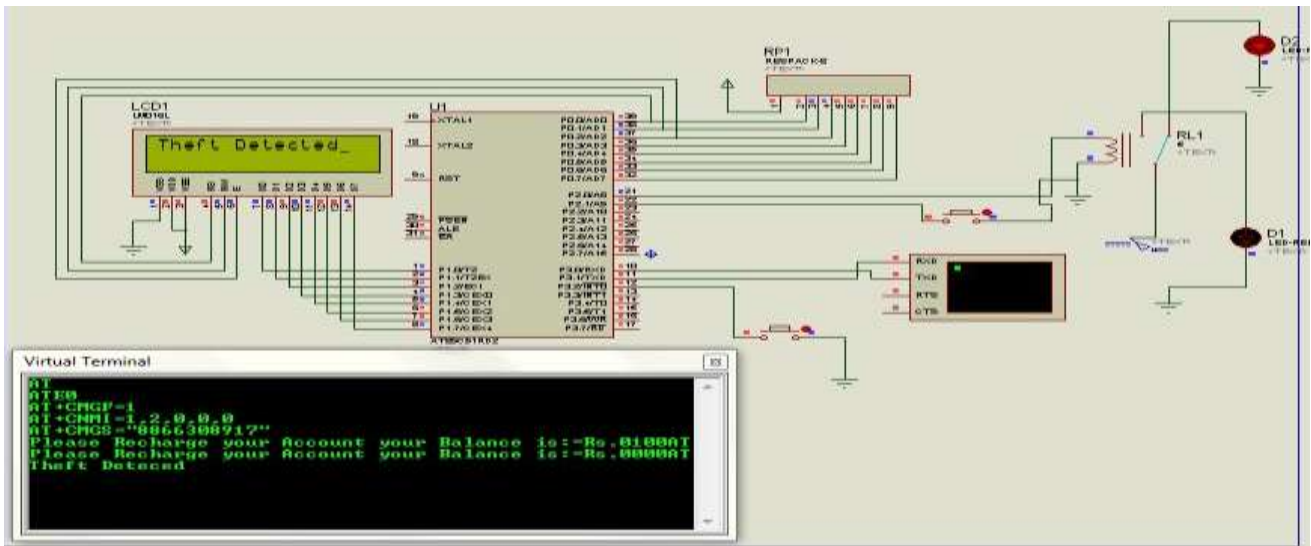

**(B) Hardware Implementation**

Shown the following figure which describe the hardware connection of the circuit diagram

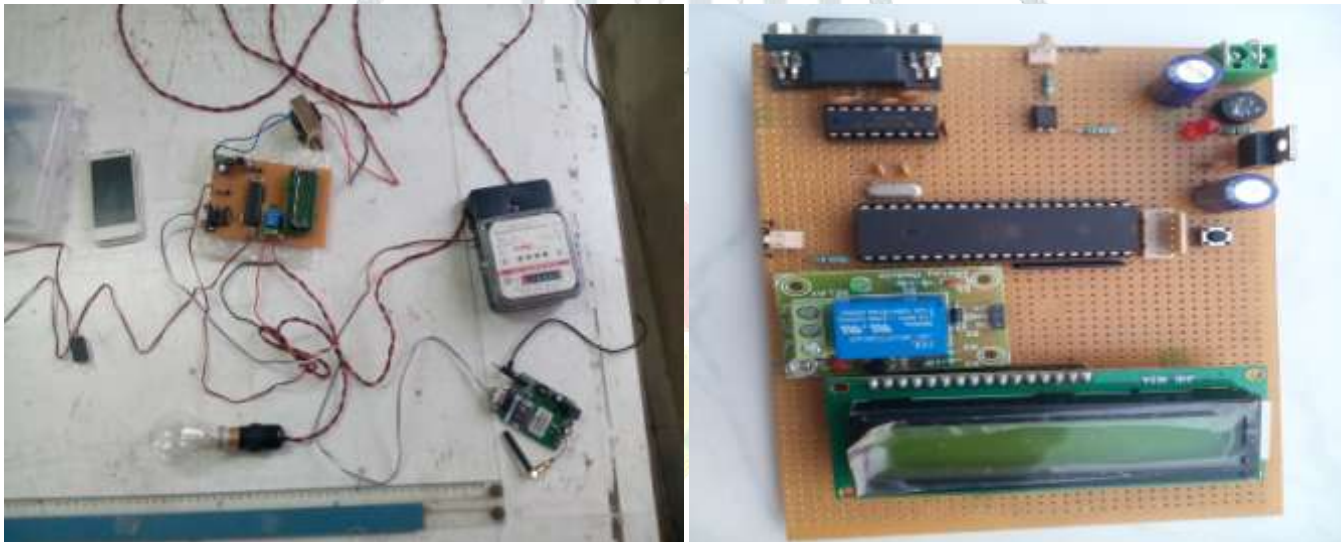

**5. Conclusion**

The paper is intended to present an overview of prepaid energy meter, which can control the usage of electricity on consumer side to avoid wastage of power. Prepaid energy meter is a concept to minimize the Electricity theft with a cost efficient manner.

1. It can reduce problems associated with billing consumers living in isolated areas and reduce manpower for taking meter readings
2. Prepaid energy meter is more reliable

**6. References**

[1] Devidas, A.R., Ramesh, M.V. “Wireless Smart Grid Design for Monitoring and Optimizing Electric Transmission in India,” 2010 Fourth International Conference on Sensor Technologies and Applications (SENSORCOMM),” pp.637-640, 2010

[2] Md. Mejbaul Haque “Microcontroller Based Single Phase Digital Prepaid Energy Meter for Improved Metering” International Journal of Power Electronics and Drive System (IJPEDS) December 2011, pp. 139~147

[3] Ling Zou, Sihong Chu and Biao Guo., “The Design of Prepayment Polyphase Smart Electricity Meter System,” International Conference on Intelligent Computing and Integrated Systems (ICISS), pp. 430-432, 22-24, Dec 2010.

[4] Loss, P et al., “A Single Phase Microcontroller Based Energy Meter,” IEEE Instrumentation and Measurement Technology Conference. St. Paul Minnesota, USA, May 18-21, 1998

[5] Prepaid Energy Meter (AT89S52) 8051 Microcontroller indianengineer. wordpress.com/.../prepaid-energy-meter at89s52.

[6] <http://www.engineersgarage.com/microcontroller/8051projects/gsm-interface-8051-microcontroller-circuit-code>