

SELF POWERED WIRELESS WATER LEVEL CONTROLLER USING ULTRASONIC SENSOR

Mr. Sanjay S. Patel

Dept of Electronics and Communication Engg, Govt Polytechnic For Girls, Ahmedabad

Abstract:

This paper presents the design and implementation of a self-powered wireless water level controller utilizing an ultrasonic sensor. The proposed system offers a novel solution for monitoring and controlling water levels in various industrial and environmental settings without the need for external power sources or wired connections. The integration of an ultrasonic sensor enables accurate and non-contact measurement of water levels, ensuring reliable performance.

Key components of the system include an ultrasonic sensor for level measurement, an energy harvesting module to generate power from ambient sources, and a wireless communication interface for data transmission. The energy harvesting module harnesses ambient energy, such as solar or vibrational energy, to power the controller and sensor, eliminating the need for batteries or external power supplies. Wireless communication capabilities enable remote monitoring and control, facilitating real-time management of water levels from a central location.

The paper discusses the design considerations, including sensor selection, energy harvesting techniques, and wireless communication protocols. Experimental results demonstrate the feasibility and effectiveness of the proposed system in accurately measuring water levels and wirelessly transmitting data in real time. Performance evaluations also highlight the system's robustness, energy efficiency, and scalability for deployment in various applications, including industrial process control, environmental monitoring, and smart agriculture.

Overall, the self-powered wireless water level controller presented in this paper offers a sustainable and cost-effective solution for monitoring and managing water levels in diverse settings, contributing to enhanced efficiency, safety, and productivity in water handling operations.

Keywords- Ultrasonic Sensor, RF Transmitter, RF Receiver, 8051 Microcontroller, Timing Generator Circuit

I. INTRODUCTION

Accurate measurement and control of water levels are essential in various industries and applications. Conventional methods of level measurement encompass mechanical, electrical, pressure-based,

and ultrasonic techniques. However, the prevailing systems in the market often rely on copper conductors as sensors, which are susceptible to corrosion. In response to these limitations, this paper introduces a novel approach utilizing ultrasonic sensors for contactless water level measurement, integrated into a self-powered wireless system driven by turbine-generated energy.

The proposed system addresses the shortcomings of traditional methods by employing ultrasonic sensors mounted on reservoirs, ensuring reliable and corrosion-resistant level

measurement. Ultrasonic sensors emit signals that are reflected off the interface between air and the water or tender material. By measuring the time taken for the signal to travel from the sensor to the water surface and back, the device determines the container's fill level without physical contact, enhancing reliability and longevity.

To power this system autonomously, we propose integrating a small turbine within the flow pipes that fill the container. As water flows through the pipes, the turbine generates energy, which is harnessed by a generator to power the sensors and controllers. This innovative approach not only eliminates the need for external power sources but also ensures continuous operation as long as water flow persists, making it ideal for remote or off-grid applications where traditional power sources are unavailable or impractical.

The integration of wireless communication capabilities further enhances the system's functionality, enabling real-time monitoring and control of water levels from a central location. By leveraging wireless technology, the system offers scalability, flexibility, and compatibility with emerging IoT frameworks, facilitating seamless integration into existing infrastructure and enabling advanced automation and data analytics.

In this paper, we present the design, implementation, and experimental validation of the self-powered wireless water level controller. We discuss the selection and optimization of turbine and generator components, energy conversion efficiency, sensor integration, wireless communication protocols, and system performance evaluation. Experimental results demonstrate the feasibility, reliability, and effectiveness of the system in accurately measuring water levels and wirelessly transmitting data in real time.

Overall, the integration of ultrasonic sensors and turbine-driven generators in a self-powered wireless water level controller represents a significant advancement in autonomous monitoring and management systems, offering a sustainable, cost-effective, and scalable solution for diverse industrial, agricultural, and environmental applications.

II. PRINCIPLE OF ULTRASONIC LEVEL MEASUREMENT

Ultrasonic waves detect an object in the same way as Radar does it. Ultrasonic uses the sound waves, and Radar uses radio waves. When ultrasonic pulse signal is targeted towards an object, it is reflected by the object and echo returns to the sender. The time travelled by the ultrasonic pulse is calculated, and the distance of the object is found. Bats use well known method to measure the distance while travelling. Ultrasonic level measurement principle is also used to find out fish positions in ocean, locate submarines below water level, also the position of a scuba diver in sea.

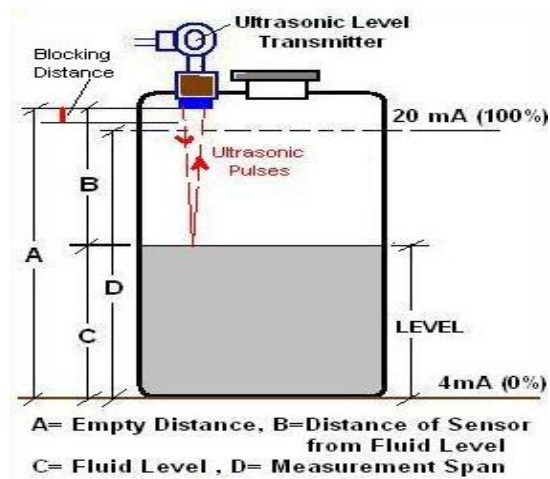

Fig.1 Ultrasonic Level Measurement

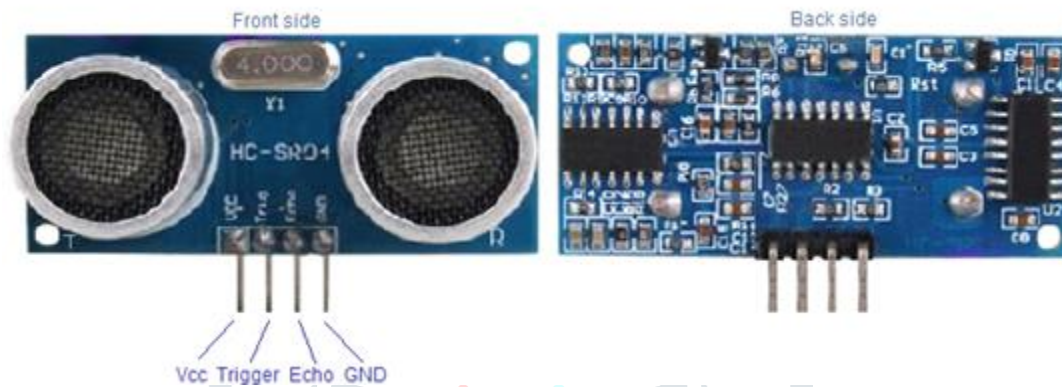

Fig.2 HC-SR04 Module

HC-SR04 is an ultrasonic ranging module designed for embedded system projects like this. It has a resolution of 0.3cm and the ranging distance is from 2cm to 500cm. It operates from a 5V DC supply and the standby current is less than 2mA. The module transmits an ultrasonic signal, picks up its echo, measures the time elapsed between the two events and outputs a waveform whose high time is modulated by the measured time which is proportional to the distance. The photograph of an HC-SR04 module is shown below.

The HC-SR04 has four pins namely Vcc, Trigger, Echo, GND and they are explained in detail below.

- 1) **VCC:** 5V DC supply voltage is connected to this pin.
- 2) **Trigger:** The trigger signal for starting the transmission is given to this pin. The trigger signal must be a pulse with 10 μ S high time. When the module receives a valid trigger signal it issues 8 pulses of 40 KHz ultrasonic sound from the transmitter. The echo of this sound is picked by the receiver.
- 3) **Echo:** At this pin, the module outputs a waveform with high time proportional to the distance.
- 4) **GND:** Ground is connected to this pin.

HC-SR04 timing diagram.

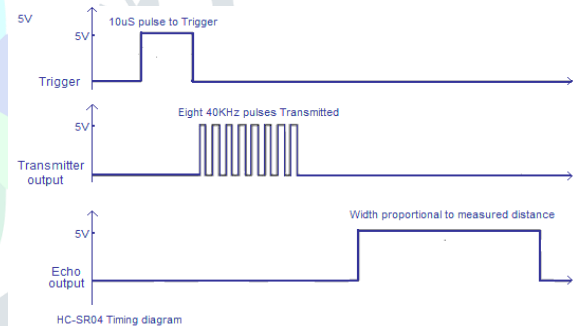

Fig.3 HC-SR04 Timing diagram

From the timing diagram, we can see that the 40 KHz pulse train is transmitted just after the 10 μ S triggering pulse and the echo output is obtained after some more time. The next triggering pulse can be given only after the echo is faded away and this time period is called cycle period. The cycle period for HC-SR04 must not be below 50mS. According to datasheet, the distance can be calculated from the echo pulse width using the following equations.

$$\text{Distance in cm} = \text{echo pulse width in } \mu\text{S}/58$$

$$\text{Distance in inch} = \text{echo pulse width in } \mu\text{S}/148$$

III. FUNCTIONAL BLOCK DIAGRAM OF SYSTEM

A micro-controller based Control Circuit monitors all the activities of the ultrasonic level transmitter. There are two

Pulse Transmission Circuits, one for transmitter pulse and the other one for receiver pulse. The pulse generated by the transmitter pulse is converted to Ultrasound pulses by the Ultrasonic Sensor (Transmitter) and targeted towards the object. This ultrasound pulse is reflected back as an echo pulse to the Ultrasonic Sensor (Receiver). The receiver converts this Ultrasonic pulse to an electrical signal pulse through the pulse generator. The time elapsed, or the reflection time is measured by the counter. This elapsed time has relation to the level to be measured. This elapsed time is converted to level by the Control Circuit. There is a Timing Generator Circuit which is used to synchronize all functions in the ultrasonic level measurement system. The level is finally converted to 4-20mA signal. 4mA is 0% level, and 20mA is the 100% level. This 4-20mA output signal carrying the level data can be transmitted to long distance to Process Control Instruments.

The first block is water level sensor. The sensor which is used in this project is Acoustic Ultrasonic sensor. This sensor is wireless so it is more reliable and convenient also. This acoustic sensor transmits and receives the Echo signal. The transmitted signal is analog so to convert it into digital we have used ADC (Analog to Digital converter). ADC will convert it into digital signal. That signal will go to HT 12E. The HT 12E will basically convert parallel data to serial and that goes to RF module transmitter. This will transmit the signal through antenna and that signal will be received at receiving side of RF module via antenna. To convert receiving signal into parallel we have used HT 12D. This will convert serial data into parallel and that data will go to micro controller 8051. 8051 is micro controller chip which used for the specific purpose. The main advantage of 8051 micro controller is that it has its internal memory so no need to connect the external memory.

LCD is interfaced with 8051 microcontroller at port-1. LCD will display the message of level of water in the tank, whether the level is low, high, medium or tank is full. Here Relay and the Motor are also connected. Relay gets ON when it is displayed on the LCD that the level is LOW and by the same time motor gets started automatically. Relay gets OFF when the level of water in the tank is HIGH or tank is FULL and at the same time Motor also gets OFF. In this we have also used Buzzer. Buzzer will buzz only when the tank is EMPTY or tank is FULL.

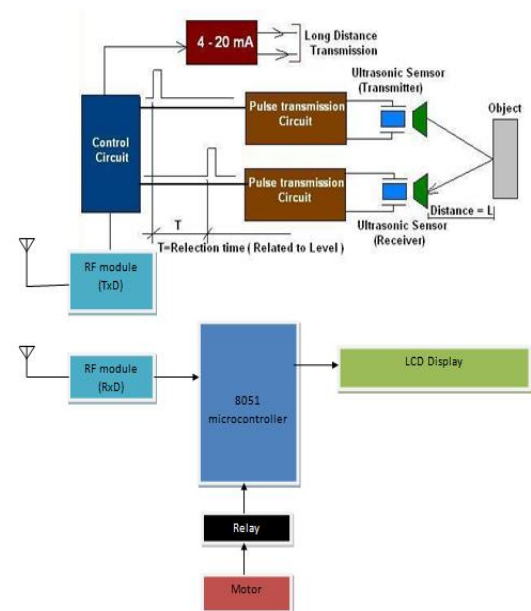

Fig.4 Basic Block Diagram of Low Power Wireless Water Level Controller

IV. RESULT

In this work, the microcontroller for the automatic water level monitor, having passed the necessary tests with the other components interfaced to it, is hereby presented. We have checked this system with water container. With this implemented system, it is possible to monitor the water level in an over-head tank, switch on the water pump when the tank is empty and switch off the same pump when the tank is full without any need for human intervention. By so doing, the incidence of water wastage is eliminated and abrupt cut-off of water supply is equally also eliminated. Here the detecting and controlling unit are connected via RF module which gives more flexibility. The LCD was interfaced to the microcontroller in order to display the status of the system as it operates. The microcontroller is able to send information or instruction codes to the LCD and equally read the contents of the LCD's internal registers. The microcontroller then processes the data received and uses it to control the pump based on the written flow or control algorithm stored in its ROM.

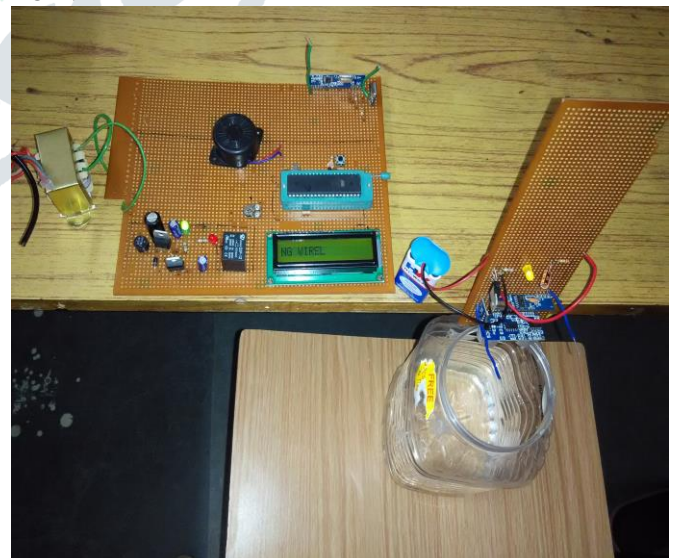

Fig.5 Hardware of Low Power Wireless Water Level Controller

V. ADVANTAGES OF SYSTEM

Ultrasonic level transmitter has no moving parts, and it can measure level without making physical contact with the object. This typical characteristic of the transmitter is useful for measuring levels in tanks with corrosive, boiling and hazardous chemicals. The accuracy of the reading remains unaffected even after changes in the chemical composition or the dielectric constant of the materials in the process fluids. The method of ultrasonic level measuring has many advantages. Some of the main characteristics of the ultrasonic level measuring method are: simplicity of installation, non-contact measuring, the material characteristics in container do not affect measuring, and low price of device. Due to its advantages the ultrasonic level measuring in container is even more often used in automated industrial plants. Also, sensor is working on self-generated power so system becomes portable, long lasting and maintenance free.

VI. DISADVANTAGES OF SYSTEM

Ultrasonic level transmitters are the best level measuring devices where the received echo of the ultrasound is of acceptable quality. It is not so convenient if the tank depth is high or the echo is absorbed or dispersed. The object should not be sound absorbing type. It is also unsuitable for tanks with too much smoke or high density moisture.

VII. CONCLUSION

Automatic low power water level control system can be used to control water level at home and industry, and other water level at industry. To implement same system for different waters need to change the microcontroller programming and hardware remains same, display the status on an LCD screen. The given design is low cost and simple circuit required to detect and control water level.

VIII. REFERENCES

- [1] Marko Ilijanić, Mato Fruk, Goran Malčić, Ultrasonic level measuring, Zagreb Polytechnic Ivana Lučića 5, Zagreb, Hrvatska
- [2] Mahmoud Meribout¹, Mohamed Habli¹, Ahmed Al-Naamany¹, And Khamis Al-Busaidi², A New Ultrasonic-based device for Accurate Measurement of Oil, Emulsion, and Water Levels in Oil Tanks.
- [3] Able Instruments & Controls Ltd, Sensors for level measurements, available from URL: <http://www.able.co.uk/level.htm.2003>.
- [4] Beginner's guide to ultrasonic level transmitter.