

# Switching Angle Estimation and THD Minimization in the Grid-Connected Multilevel Inverter

<sup>1</sup>Cheeli.Rama Krishna,<sup>2</sup>J.Hema Latha.

<sup>1</sup>M.Tech Scholar,<sup>2</sup>Sr.Assistant Professor.

<sup>1,2</sup>Department of EEE.

<sup>1,2</sup>Prasad V. Potluri Siddhartha Institute of Technology, Vijayawada, India

**Abstract:** The multilevel inverter with disunite dc sources is a better choice as an interface between the grid and distributed energy resources (DERs). The point of common coupling (PCC) has the tremendous role in the grid-connected applications, for that voltage quality at the PCC is most important than the inverter output voltage. This paper brings a fundamental frequency switching method to mitigate voltage harmonics for the grid-connected cascaded H-bridge multilevel inverter at the point of common coupling (PCC). In this paper first, the harmonic mitigation by using the conventional switching method was presented, after that, a Genetic Algorithm optimization based program proposed to minimize the THD of the PCC voltage and the harmonic contents of the inverter output voltage. Here the main aim is to calculate optimum switching angles of the inverter. These switching angles must satisfy the standard limits for the inverter output voltage and the total harmonic distortion by considering the specifications of the grid. The switching angles are to be employed for a seven-level cascaded h- bridge multilevel inverter connected to an ac power grid. The conventional method and the GA optimization method for calculating switching angles were implemented in MATLAB/Simulink environment. The results show the effectiveness of the genetic algorithm optimization method.

**Keywords; Multilevel inverter, Switching angles, Point of common coupling, THD, GA optimization.**

## I. INTRODUCTION

In the present scenario power industrial applications are mainly based on the high rated power apparatus. Some medium, high voltage motor drives and the utility applications require medium voltage and different ranges of power level. For the medium voltage grid, it is inconvenient to connect only one power semiconductor switch directly. Then a multilevel power converter device has been used as an alternative in high power and medium voltage situations. A multilevel power converter not only achieves high power ratings but also gives the use of renewable energy systems. The renewable energy sources such as photovoltaic, wind, and fuel cells can be easily interfaced to a multilevel converter system for high-power medium voltage applications [1]. The main advantages of multilevel inverters are:

- Medium and high voltage capability,
- Switching losses must be reduced,
- low dv/dt,
- The THD of system is less,
- The electromagnetic compatibility should be minimum.

The main three types of multilevel inverter are diode clamped (neutral point converter) type, flying capacitor type and cascaded H-bridge multilevel inverter.

The switching angles of inverter have enormous importance in the turning ON and OFF the switches in the inverter circuit. The main group of switching strategies operates at the fundamental frequency in which the switching devices turned on and off only once per cycle to overcome the switching loss problem. This results in higher efficiency of the inverter [2]. The various pulse width modulation techniques have been used for controlling inverter output voltage. The selective harmonic elimination pulse width modulation technique (SHEPWM) of the fundamental frequency switching strategy type had been used in this paper [3]. This type of switching strategy is the low-frequency switching type. Strategies that having low switching frequencies mainly performs one or two commutations of the switches during one cycle of the output and creates a staircase output waveform. The harmonic contents of the output voltage decreased with respect to the number of levels increased [4].

For the grid-connected system, the parameters like voltage quality, power flow control, and the harmonic analysis are more important at the point of common coupling than the inverter output voltage [5]. Hence the controlling of the output voltage and the power flow at PCC should be controlled by achieving the proper switching angles according to the specifications of the power grid. The switching angles of the inverter output voltage are obtained by solving the non-linear transcendental equations as per the constraints. Mathematically solving this type of equations is a problem for getting the switching angles, various iterative methods and optimization methods are there for solving these type equations. Different techniques are there for the elimination of harmonics and solving the equations [6].

In this paper first, the selective harmonic elimination based conventional switching method has been proposed, after that the switching angles are obtained by the genetic algorithm optimization method. In the conventional switching method, the Newton Raphson (NR) method has been used by the iterative process. For the NR method, the switching angles are mainly obtained based on the proper guess of initial switching. Then the switching angles are to be iterated for different values of modulation index [7]. The required angles are to be taken for the PWM technique to the seven-level inverter and then the total

harmonic distortion of the inverter output line voltage and the PCC line voltage was calculated by using the FFT analysis in MATLAB/Simulink.

Recent advances in computation and the search for better results for complex optimization problems have stimulated the development of a family of techniques known as Evolutionary Algorithms (EA). EA are stochastic based optimization techniques that search for the solution of problems using mathematical models that simulate the biological evolutionary process [8]. These algorithms provide an alternative for obtaining global or near global optimal solutions, particularly in the presence of non-continuous, non-convex and wide solution spaces. Genetic Algorithm (GA) is an effective optimization method for solving complex problems. This method has no limit on the optimization space. Therefore, it is insensitive to the local optimum points and finds the absolute optimum point in all cases if calculation time is not limited [9]. The GA is applied in many industries for control processes. In this paper, a GA based method has been proposed for solving the complex equations in an SHE-PWM problem. Thus, the issue of an intelligent guess for the initial point has been eliminated. The maximum harmonics elimination has been optimized using the GA method [10]. In this paper, the GA optimization program based on the fitness function was developed in the MATLAB environment.

The switching angles obtained from the NR method and GA optimization methods were given to the seven-level cascaded H-bridge multilevel inverter connected to an AC grid. The THD at inverter output voltage and at PCC line voltage calculated by using the FFT analysis. Finally, the THD results in both the methods are compared in this paper.

## II. MULTILEVEL INVERTERS

Multilevel inverters are tremendous interest due to their medium and high voltage operation capability, minimum switching losses, increased efficiency and the reduction in the output of Electro Magnetic Interference (EMI). The term multilevel starts with the three-level inverter introduced by Nabae et al (1981). In the present scenario, multilevel inverters are becoming increasingly popular in power applications, as multilevel inverters have the ability to meet the increasing demand of power rating and power quality associated with reduced harmonic distortion and lower electromagnetic interference [1].

A multilevel inverter has several applications over a conventional inverter that has high switching frequency pulse width modulation (PWM). The most attractive features of a multilevel inverter are as follows:

- I. They can generate output voltages with extremely low distortion and lower  $dv/dt$ .
- II. They draw input current with very low distortion.
- III. They generate smaller common-mode (CM) voltage.
- IV. They can operate with a lower switching frequency.

There are three main types of multilevel inverters: diode-clamped (neutral-clamped), capacitor-clamped (flying capacitors), and cascaded H-bridge inverter.

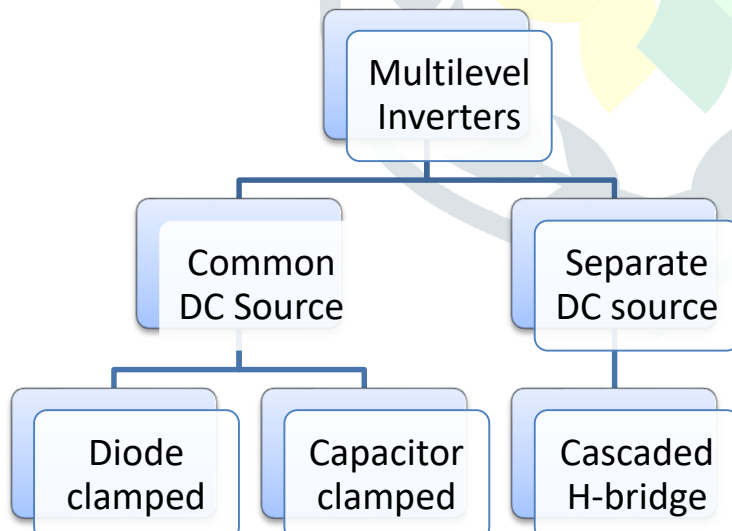

fig1: Topology of Multilevel Inverters

### ❖ Cascaded H-bridge Multilevel Inverter:

The cascaded H-bridge inverter has drawn tremendous interest due to the greater demand of medium-voltage high-power inverters. The cascaded inverter uses series strings of single-phase full-bridge inverters to construct multilevel phase legs with separate dc sources. Cascaded H-bridge cell inverters use the least number of power electronic devices when compared to any other topology [11]. The series structure allows a scalable, modularized circuit layout and packaging due to the identical structure of each H-bridge, no extra clamping diodes or voltage balancing capacitors are not necessary, switching redundancy for inner voltage levels is possible because the phase voltage is the sum of the output of each bridge. The schematic diagram of the cascaded H-bridge multi level inverter is shown fig 2.

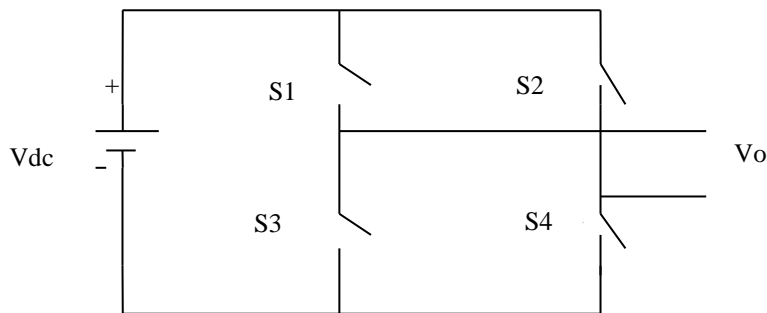
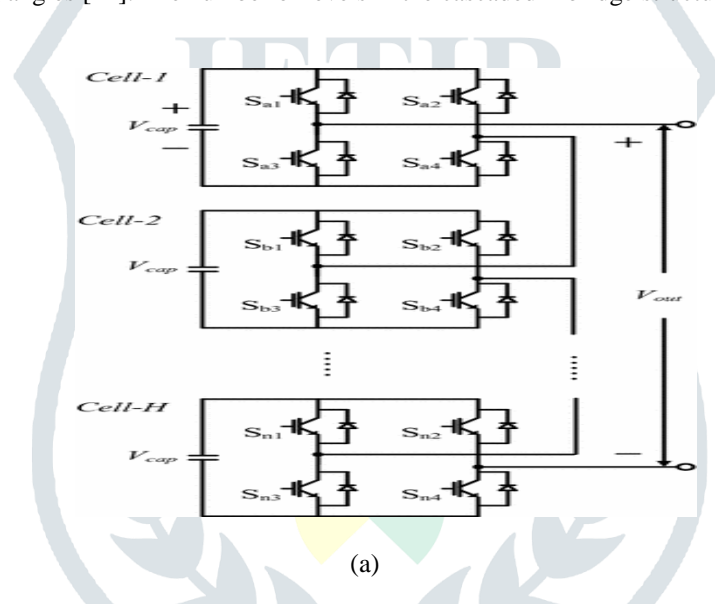
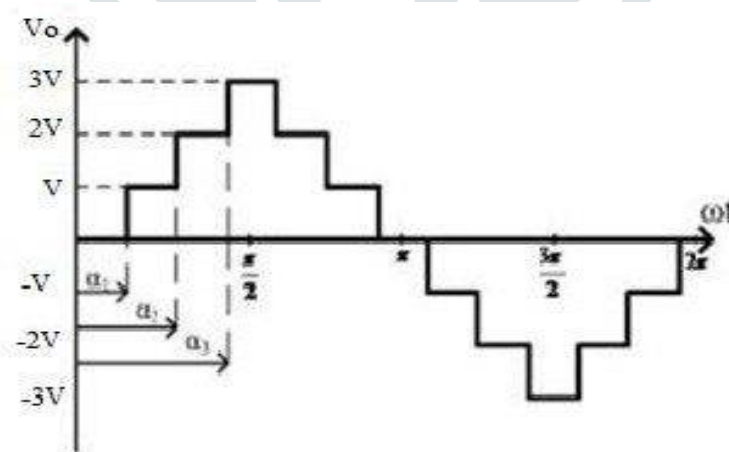

fig 2: Single phase H-bridge with DC source

Suppose if we have to take a single phase H-bridge as shown in fig. the four switches are controlled to generate the output  $V_o$  with the levels of  $V_{dc}$ . When the switches  $S_1$  and  $s_4$  are turned on according to the switching angle then the output voltage is  $+V_{dc}$ , if the switches  $S_2$  and  $S_3$  are ON then obtained voltage are  $-V_{dc}$ , the output voltage is 0 either of the switches  $S_1$  and  $S_2$  or  $S_3$  and  $S_4$  is turned ON. In this manner for the cascaded h-bridge multi levels the switching pattern is given to the series structure of the bridges. The cascaded h-bridge structure and the stepped waveform related with their switching angles are shown in fig 3. For the seven-level inverter three DC sources are required. The switching devices are to be turned ON at different instants based on the switching angles [12]. The number of levels in the cascaded h-bridge structure is given by  $N=2S+1$ . Here  $S$  is the number of sources.



(a)



(b)

fig 3 (a) & (b): Cascaded H-bridge multilevel inverter and its structural waveform

The modulation methods used in multilevel inverters can be classified according to the switching frequency, modulation techniques that work with high switching frequencies have many commutations for the power semiconductors in a cycle of the fundamental output voltage. Multilevel inverters generate sinusoidal voltages from discrete voltage levels, and Pulse Width Modulation (PWM) strategies accomplish the task of generating sinusoids of variable voltages and frequencies. The three

multilevel modulation methods most discussed are multilevel carrier-based sinusoidal PWM, selective harmonic elimination, and multilevel space vector PWM [2].

The selective harmonics elimination method is based on the harmonic elimination theory was developed by Patel and Hoft (1973). A multilevel inverter can produce a quarter-wave symmetric stepped voltage waveform synthesized by several DC voltages. To minimize harmonic distortion and to achieve adjustable amplitude of the fundamental component, up to  $k-1$  harmonic contents can be removed from the voltage waveform. In general, the most significant low-frequency harmonics are eliminated by properly selecting angles among different level inverters, and high-frequency harmonic components can be removed by using additional filter circuits [15]. The output is a staircase waveform with steps angle duration optimized to cancel the specified harmonics.

To keep the number of eliminated harmonics at a constant level, all switching angles must satisfy the condition  $0 < \alpha_1 < \alpha_2 < \alpha_3 < \dots < \alpha_s < 90^\circ$  or the THD increases dramatically. However, if the switching angles do not satisfy the condition, this scheme no longer exists. Due to this reason, this modulation strategy basically provides a narrow range of modulation index, in a seven-level equally stepped waveform, the modulation index is only available from 0.2 to 1.15.

### III. SWITCHING ANGLE PROBLEM FORMULATION FOR GRID CONNECTED MULTILEVEL INVERTER

Suppose the cascaded H-bridge multilevel inverter is connected to an ac grid the at the PCC bus via the coupling impedance the power flow to be exchanged [13]. The schematic circuit diagram of grid-connected CHBMLI is shown in fig 4. Here  $Z_{inv}$  and  $Z_{grid}$  are the inverter impedance and the grid impedance.

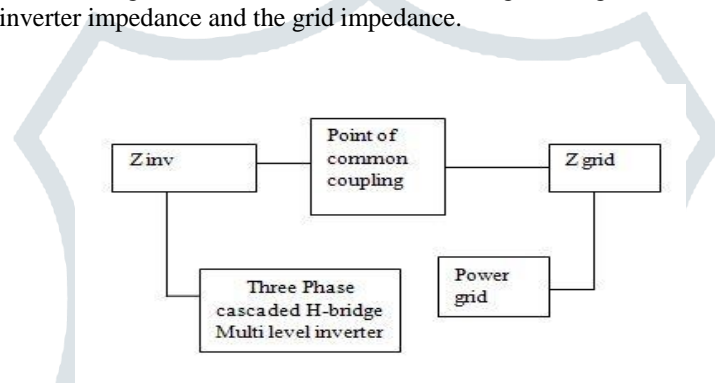

fig 4: Three phase cascaded H-bridge multilevel inverter connected to the power grid

Voltages of the inverter dc sources are  $V_{dc}$  and all are to be constant, then the Fourier series expansion of the inverter output voltage is given by,

$$V_{inv}(\omega t) = \sum_{n=1}^{\infty} \left[ \frac{4V_{DC}}{n\pi} \sum_{k=1}^s \cos n\alpha_k \right] \sin(n\omega t + n\delta) \quad (1)$$

Here is the  $k$ th switching angle of the inverter,  $S$  is the no. of dc sources in the inverter. The Amplitude of the  $n$ th harmonic inverter output voltage is

$$V_n = \frac{4V_{DC}}{n\pi} \left[ \sum_{k=1}^s \cos \alpha_k \right] \quad (2)$$

The modulation index of the inverter is defined as the ratio to the fundamental component to the per unit value, which is mathematically given as

$$\text{Modulation index, } m = \frac{\sqrt{2}V_1 \cdot \pi}{4s \cdot V_{DC}} \quad (3)$$

Here  $V_1$  is the fundamental component of the inverter output voltage.

Normally for a seven-level H- bridge multilevel inverter the range of the modulation index may vary from 0.2 to 1.2 By taking the inverter output voltage and the grid voltage then the fundamental component of the PCC voltage will be,

$$V_{PCC1} = \frac{Z_{grid}}{Z_{total}} V_1 + \frac{Z_{inv}}{Z_{total}} V_{grid} \quad (4)$$

The  $n$ th harmonic of the PCC voltage will be given by,

$$V_{PCCn} = \frac{Z_{n(grid)}}{Z_{n(total)}} V_{n(grid)} \quad (5)$$

By considering the eq (2) and (5) for the operating point of the interfaced inverter the equations for the harmonic mitigation by using the selective harmonic elimination method at PCC can be written as.

$$\sum_{k=1}^s \cos \alpha_k = S.m \quad (6)$$

From the eq. (6) the following equations are to be derived,

$$\cos \alpha_1 + \cos \alpha_2 + \cos \alpha_3 = S.m \quad (7)$$

$$\cos 5\alpha_1 + \cos 5\alpha_2 + \cos 5\alpha_3 = 0 \quad (8)$$

$$\cos 7\alpha_1 + \cos 7\alpha_2 + \cos 7\alpha_3 = 0 \quad (9)$$

The above equations are in transcendental form and it can be difficult to solve. Here the main aim is for solving the switching angles  $\alpha_1$ ,  $\alpha_2$ ,  $\alpha_3$  and reducing the harmonic contents at the inverter output voltage and at the PCC line voltage. The condition for the switching angles is:

$$0 < \alpha_1 < \alpha_2 < \alpha_3 < \dots \dots \leq \frac{\pi}{2}$$

#### IV. SWITCHING ANGLE CALCULATION USING NR-METHOD

The Newton Raphson method is one of the widely used and well established techniques to solve non-linear equations. The NR method is applied to solve Selective Harmonic Elimination equations to obtain feasible switching angles to mitigate harmonics [7]. Though this technique is the dominant one, but it suffers from the drawback of the good initial guess. Since the required output is unknown, providing a good initial guess is so complex. Hence any random initial guess is chosen. It is applied to calculating the roots of the equations.

For achieving the required switching angles the eq (7), (8) & (9) are solved by using the NR-method. The basic steps involved in the development of the Newton Raphson algorithm are:

**Step1:** Choose any random initial guess for switching angles.

**Step2:** Set the modulation index value,  $m=0.1$

**Step3:** Calculate eq (7), (8) & (9) accordingly initial guess of switching angles ( $\alpha$ ), B ( $m$ ) & Jacobean matrix J ( $\alpha$ ).

**Step4:** Calculate the error  $d\alpha, d\alpha = \alpha \left[ \frac{df}{d\alpha} \right]^{-1} [B[m] - J[\alpha]]$

**Step5:** Update the switching angles

$$\alpha(n+1) = \alpha(n) + d\alpha(n).$$

**Step6:** Repeat the steps from 3 to 5 for different iterations for optimum switching angles.

**Step7:** Increment  $m$  by stepwise.

**Step8:** Reiterate the steps 2 to 7 for the complete values of modulation index.

The above algorithm is developed in the MATLAB software for obtaining proper switching angles according to the constraints.

#### V. SWITCHING ANGLE CALCULATION USING GENETIC ALGORITHM OPTIMIZATION METHOD

Nature follows a very interesting path to select an optimum solution for any problem. By generations, it chooses and keeps the best and fittest solutions as a survivor and discards the rest other options. The fittest solutions again evolve continuously as the testing ground of nature gets more difficult. This is a continuous and almost flawless process to find out the most optimum result. We all know this process under the heading "Survival of the Fittest" [8].

The Genetic algorithm is a computational model that solves optimization problems by imitating genetic processes and the theory of evolution by using genetic operators like reproduction, crossover, mutation etc. Amounts of applications have benefited from the utilization of genetic algorithm. The Genetic algorithm is still a novel technique for PWM-SHE technique. This algorithm is usually used to accomplish a near global optimum solution. Each iteration of the GA is a new set of strings, which are called chromosomes, with improved fitness, is produced using genetic operators [9]. The flow chart of the genetic algorithm is shown below fig5.

The steps involved in formulating the problem by using the genetic algorithm optimization process are given below.

**Step1:** Select binary or floating point string for the Encoding process.

**Step2:** Find the no. of variables according to the given problem.

In this paper for the seven-level inverter, three switching angles are to be needed and then the no. of variables is 3, i.e. ( $\alpha_1$ ,  $\alpha_2$ ,  $\alpha_3$ ). For that, each chromosome needs three switching angles.

**Step3:** Select a population size and initialize the population.

**Step4:** Evaluate the fitness function.

The main important aspect of the GA optimization process is to evaluate the fitness function. The objective function of this paper is to minimize harmonics according to the switching angles. The fitness function can be formulated according to the harmonic components of the voltage waveform.

$$\text{Fitness function} = 100 * \frac{\sqrt{\sum_{n=5}^{199} V_{PCCn}^2}}{V_{PCC}} \quad (10)$$

For the seven-level inverter the 5<sup>th</sup> and 7<sup>th</sup> harmonic components should be minimized and hence the fitness function is given by;

$$\text{Fitness function} = \frac{|V_{PCC5}| + |V_{PCC7}|}{|V_{PCC1}|} \tag{11}$$

The fitness function can be evaluated for different chromosomes according to the switching angle set  $(\alpha_1, \alpha_2, \& \alpha_3)$ .

**Step5:** The above GA algorithm is run several times for getting the optimum switching angles according to fitness value. If the obtained switching angles are not in order the chromosomes are undergone to the genetic operators like selection, crossover, and mutation.

By the application of genetic operator the new chromosome set formed for different no. of iterations, which chromosome set can satisfy standard conditions that set should be taken for the required switching angle set [14].

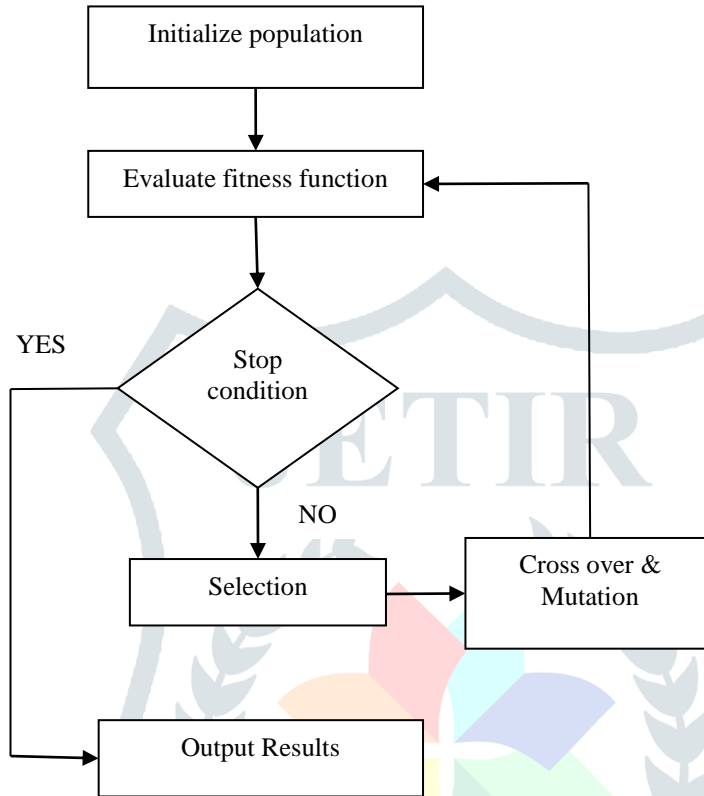

fig5: Flowchart for Genetic algorithm optimization process

**VI. SIMULATION RESULTS AND DISCUSSIONS**

The sample system employed for NR and GA switching methods by using seven-level cascaded H-bridge multilevel inverter is shown below fig 6. The parameters for the power grid and the inverter are in Table (1). The schematic simulation diagram for a simple H-bridge inverter with switching devices, pulse generator and the DC source is shown in fig 7. The simulation parameters required for the pulse generator are calculated by the switching angles, which are obtained by the NR-method and GA optimization method. The PWM technique used for switching the devices is the selective harmonic elimination technique. In this method the solution for the switching angles was determined by solving the transcendental equations in different methods. The solution for the switching angles in both the NR and GA optimization methods are presented in the following sections.

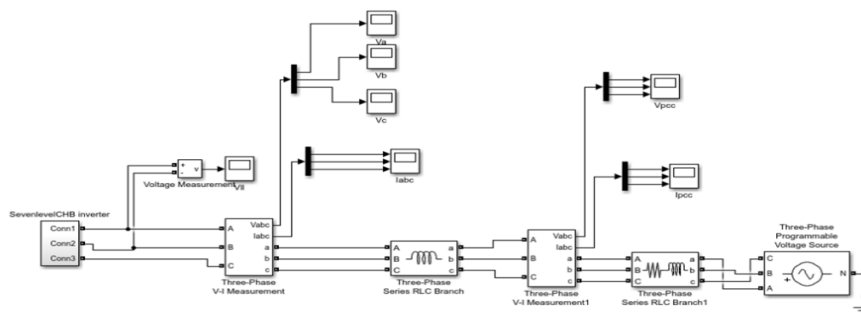

fig6: Sample system of grid connected inverter for switching methods.

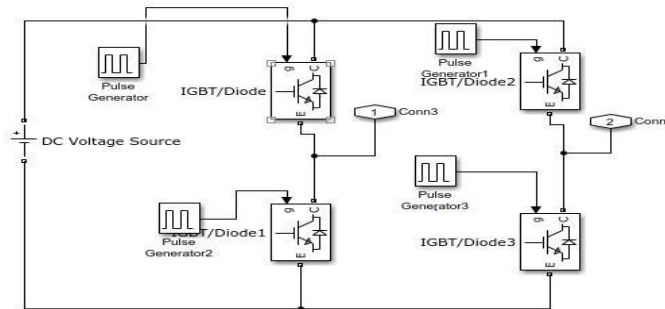

fig7: H-bridge inverter Simulation

Table1: Grid and Inverter parameters

Grid parameters		Inverter parameters	
Rms of the phase voltage	230v	DC Source voltage	100v
Eq. resistance	0.6ohm	Switch type	IGBT
Eq. inductance	1.2mH	Internal resistance	0.001ohm

**6.1 Solution using NR method:**

From the NR method the switching angles obtained are:

$$\alpha_1=14.04^\circ, \alpha_2=17.4^\circ \text{ and } \alpha_3=31.24^\circ.$$

From the switching angles the required simulation parameters were calculated for giving the firing in pulse generator in the simulation for a simple H-bridge circuit shown in fig 7.

**6.1.1 Inverter output voltage:**

The line voltages in three phases at the inverter output voltage is shown below. By using the FFT analysis the THD value at inverter output voltage obtained is 10.90%. The fig 8(a) & (b) demonstrates the inverter output line voltage in three phases and the harmonic spectrum according to their corresponding optimum switching angles.

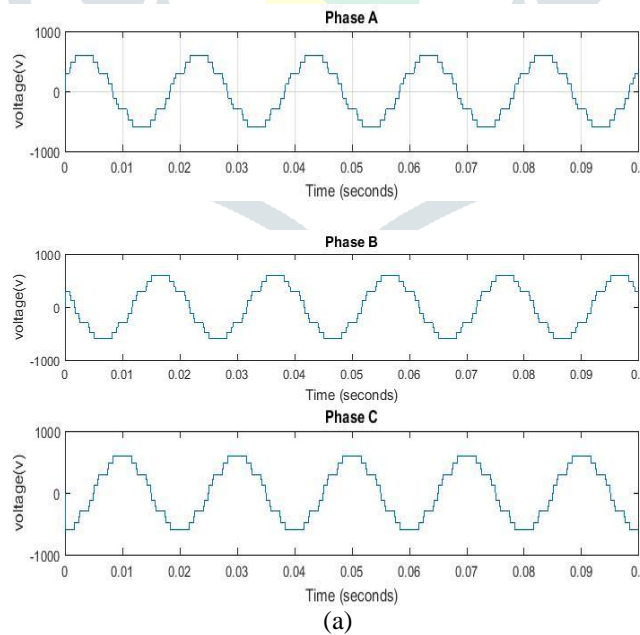

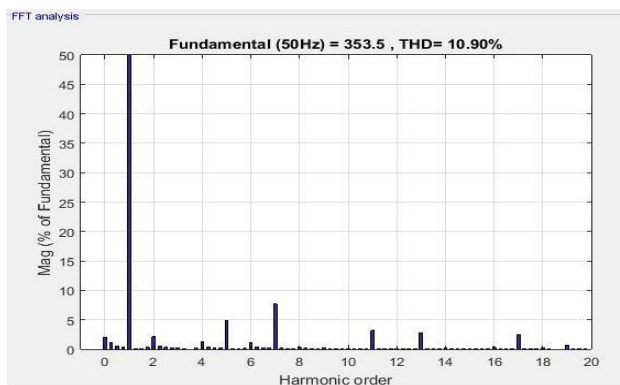

(b)

fig 8: (a) Inverter output line voltages(b) Harmonic spectrum

6.1.2 PCC Output Voltage:

At the point of common coupling the three phase line voltage waveform is shown in fig 9(a) .The Fig 9(b)demonstrates the amount of the THD from the FFT analysis of the PCC output voltage and its value is 7.49%.

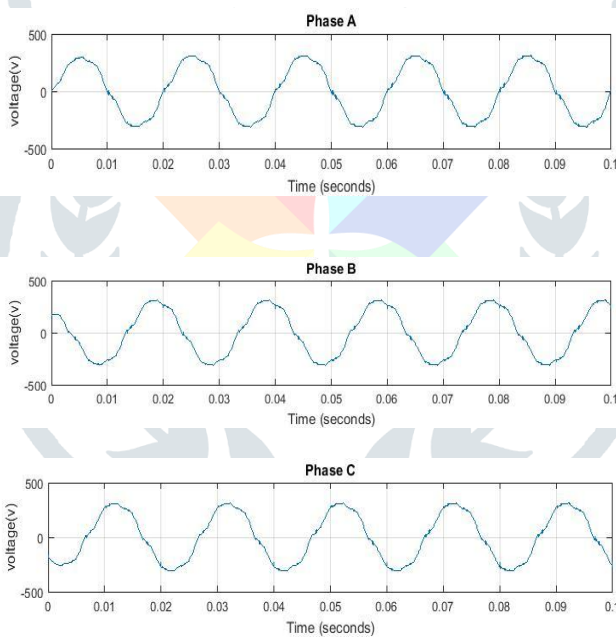

(a)

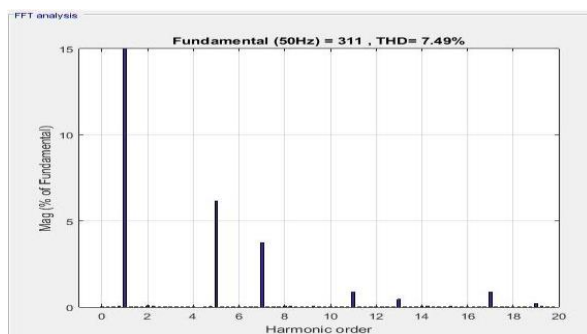

(b)

fig9: (a) PCC line voltages (b) Harmonic spectrum



**6.2 Solution using GA optimization method:**

From the GA optimization the getting switching angles are

$$\alpha_1=11.65^\circ, \alpha_2=25.26^\circ \text{ and } \alpha_3=55.24^\circ.$$

From the above switching angles the required simulation parameters were calculated for giving firing to the commutation of the switching devices in the H-bridge as shown in fig7.

**6.2.1 Inverter output voltage:**

The three phase line output voltages and the THD diagram using the FFT analysis in this method are shown in fig 10(a) & (b). The amount of THD by the FFT analysis for the line voltage is 8.94%.

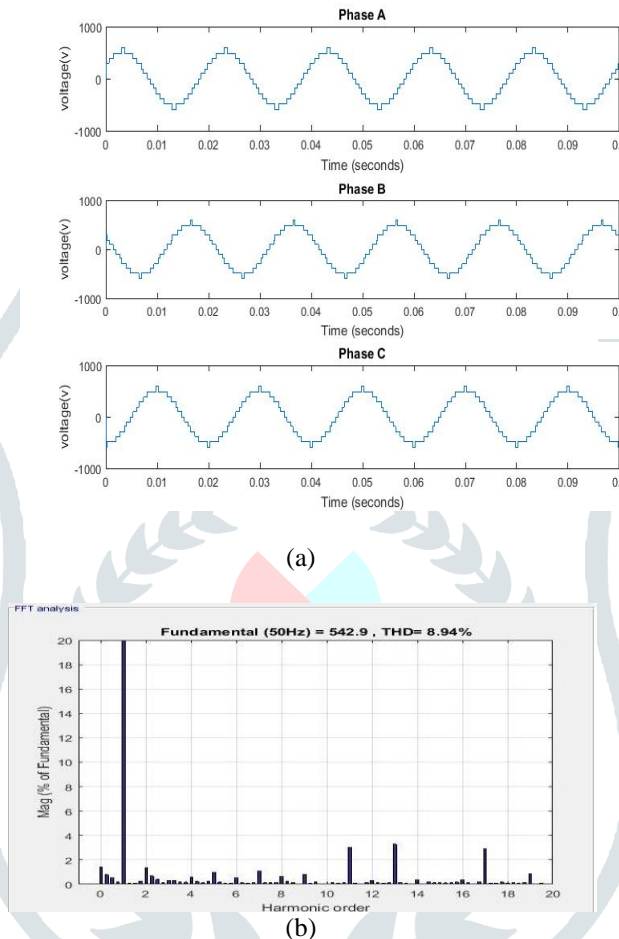

**fig10: (a) Inverter output line voltages (b) Harmonic spectrum**

**6.2.2 PCC output voltage:**

The THD at the point of common coupling by using GA optimization program is 4.54%. The line voltages for the three phases and its harmonic spectrum analysis are shown in fig 11(a) & (b).

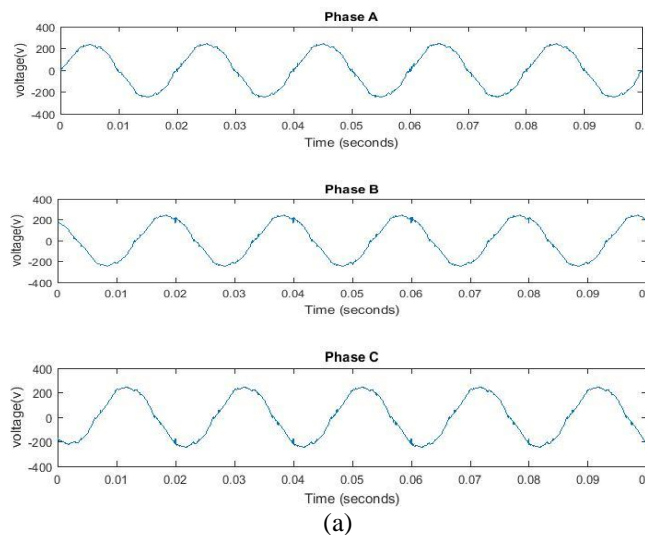

(a)

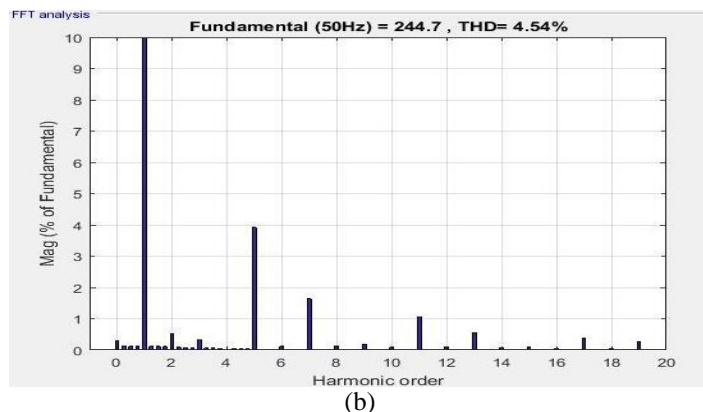

fig11: (a) PCC line voltages (b) Harmonic spectrum

Table2: Comparison of THD values in NR and GA methods

Parameter	NR-method		GA optimization method	
	At Inverter line Voltage	At PCC line voltage	At Inverter line voltage	At PCC line voltage
Fundamental output voltage(v)	528.17	301.8	608.51	417.70
Rms output voltage(v)	360.04	211.82	365.43	219.26
THD (%)	10.90	7.49	8.94	4.54

By using the GA optimization method the harmonic contents in the inverter output voltage and as well as at the PCC voltage waveform are minimized compared with the conventional method (NR-method). The GA method can give the best results than the NR-method. The comparison table for the THD values in the NR-method and the GA optimization method are given in the table 2. From that the amount of the THD in the GA optimization method should be less. The results show the strength of the GA over the NR-method.

**VII. CONCLUSION**

For the grid- connected applications at the point of common coupling the voltage quality is the main concerned factor than the inverter output voltage. In this paper the main aim is to estimate the best switching angles according the specifications. The GA optimization program and the NR- method are applied for the estimation of the switching angles. The attained switching angles are given to the three phase cascaded H-bridge seven level inverter connected to the power grid. From the MATLAB/Simulink simulation results the voltage quality, the harmonic spectrum analysis at inverter output and at the point of common coupling is analyzed. From that it is observed that the THD values obtained in the GA optimization method is less compared with the NR-method. Hence the GA optimization method has the best results and it is most effective method for minimizing the harmonic contents in the output voltage waveform. The THD of the system is to be minimized by increasing the number of levels of multilevel inverter as per the IEEE standards.

**REFERENCES**

[1] A El-Hosainy, Hany A.Hameed, Haithan Z.Azazi, E.E El-Kholy “A review of multilevel inverter topologies, control techniques and applications” 19<sup>th</sup> International middle east power systems conference, pp: 1265-1275, 2017.  
 [2] V. Sandeep Singh Thomar, N.Agarwal,Praveen Bansal “Various modulation techniques in symmetrical multilevel inverters” International conference on energy ,communication, data analytics and soft computing ,pp:1322-1327,2017.  
 [3] B.Hemanth Kumar, M.M.Lokhande “Analysis of PWM Techniques on three phase cascaded H-bridge multilevel inverters”, recent developments in control, automation and power engineering, pp: 465-470, 2017.  
 [4] Milan S.Aidar Zhetesol,T.AlizadehYakov L.Fanilant “Simultaneous Selective harmonic elimination and THD minimization for single phase multilevel inverter with staircase modulation” IEEE Transactions on industry applications,vol:54,issue:2,pp:1532-1541,2015.

- [5] Shahb Sajedi, Malabika Bosu, M.Farrel “New grid tied cascaded multi level inverter topology with reduced no. of switches “52nd international universities power energy conference, pp: 1-6, 2017.
- [6] A.Shrma, K.S.Kashyap “Harmonic minimization in multilevel inverters using numerical series technique” International conference on power, control, signals and instrumentation engineering, pp: 2013-2103, 2017.
- [7] Md.Rasheed, Rosli Omar, M.Sulaiman “Comparative performance of harmonic reduction based on Newton Raphson”, 4th IET clean energy and technology conference, pp: 1-7, 2016.
- [8] Khalili T. Eddine, Railal Adderhadi, B.Omar, O.hussain “A new multilevel inverter with GA optimization for hybrid power station applications” 4<sup>th</sup> international conference on optimization pp: 01-06, 2015.
- [9] P. Maruth Pandi, N.Devarajan “Optimization of power quality in cascaded multilevel inverter genetic algorithm approach” 2<sup>nd</sup> international conference on computing, communication and technology, pp: 1-7, 2015.
- [10] Darshan Kumar, Dr. Swapnajit Pattnaik, Mrs. Varsha Singh “Genetic Algorithm Based Approach for Optimization of Conducting Angles in Cascaded Multilevel Inverter” International Journal of Engineering and Applications (IJERA) ISSN: 2248-9622 Vol. 2, Issue3,2012.
- [11] Farhadi Kangarlu, M., Babaei, E.: ‘A generalized cascaded multilevel inverter using series connection of sub-multilevel inverters’, IEEE Trans. Power Electron Issue 3, ISSN: 2278-621X, 2014.
- [12] Hema Latha Javvaji, B. Basava Raja “Simulation and analysis of different parameters of various levels of cascaded H-bridge multilevel inverter”, IEEE conference on power electronics, 2013.
- [13] Mehdi Hajizadeh , Seyed Hamid Fathi “Fundamental frequency switching strategy for grid-connected cascaded H-bridge multilevel inverter to mitigate voltage harmonics at the point of common coupling”, IET power electronics, ISSN 1755-4535,2016,pp 2387-2393.
- [14] Subhadip Samanta, “Genetic Algorithm: An Approach for Optimization (Using MATLAB)” International Journal of Latest Trends in Engineering and Technology (IJLTET), Vol.3 Issue 3, ISSN: 2278-621X, 2014.
- [15] P.Mamatha, Challa Venkatesh, “Performance improved Multilevel inverter with selective harmonic elimination PWM technique ,” in Int. Conf. of recent trends in electrical, electronics and computing technologies, pp:133-138,2017.

