

# Automation in two wheeler by using sensor

<sup>1</sup>Aher Chetana Suresh,<sup>2</sup>Dahale Shruti Anil,<sup>3</sup>Sanap Shraddha Bhikan

<sup>1</sup>Student,<sup>2</sup>Student,<sup>3</sup>Student

<sup>1</sup>Information Technology

Nashik District Maratha Vidya Prasarak Samaj's

Karmaveer Adv. Baburao Ganpatrao Thakare College of Engineering, Nashik, India

*Abstract:* Most of the people make use of two-wheeler for their travel, which is most convenient, economical channel of transport in India. Hence keeping this in consideration, the automation in two-wheeler is a vital task and it must be faster and efficient as the demand (travelers) is very high. This paper makes it possible for end user a luxury travelling with two-wheeler. This paper will be able to provide some functionality which operates by using sensors. There are many features we will provide through this project are listed as follows: Automatic opening and closing of footrest, No ignition when side stand is open, Smart Helmet, Accident happens message transfer to nearest police station, nearest hospital and parent, Head lamp light control at day or night time by sensors according to surrounding mist density.

**Keywords:** GPS Module, Internet of Things, LDR sensor module, Proxy Sensor, Raspberry pi.

## I. INTRODUCTION

The IOT (Internet of Things) is a network of different things which includes physical devices, vehicle, home appliances and other items which are embedded with different software, sensor, actuators and connectivity which connect and exchange the data. These things are creating opportunities for more direct integration of the physical world to computer based system it result in improvement of efficiency, reduce human exertion and benefits of economics. The IOT devices usages has been increased a lot year over-year from 8.4 billion in the year 2017 and it is estimated that there will be 30 billion devices by 2020. The global market value of IoT is projected to reach \$7.1 trillion by year 2020. The Internet of things has evolved multiple technologies such as machine learning, real-time analytics, and different commodity sensors and embedded system. Embedded system of traditional fields, wireless sensor network, control system and automation these all things are contribute to enables the internet of things. The IOT devices is obtain divided into four types such as commercial, consumer, industrial and infrastructure spaces.

In Our Project we are going to apply the concept of sensor on foot rest of any two wheeler. Generally if a person sit behind the driver he has to open the foot rest manually. This makes it difficult for the person of various age groups. It is mostly difficult for senior citizens as they have back problem. And it also becomes difficult for driver as the person sitting behind driver forgets to open the foot rest so he tries to open it at the time of driving. In such case, the driver can lose his balance and accident can occur In order to avoid such problems and accidents we are designing a foot rest having sensor, which will detect the person is sitting behind and it will automatically open.

Any two wheeler vehicles stand still stand. Sometimes, it happens that driver forgets to remove the vehicle from stand. In such case the accident can occur as drier is driving the vehicle irrespective, of the fact that it is still on the stand. In order to overcome such problem, we will design stand of vehicle having sensor. This sensor will detect that driver has been sited and ready to go, so stand will be removed automatically. Today's, wearing helmet is a strict rule so to make sure that every driver should follow the rule.

We are going to design a smart helmet concept. This smart helmet has two advantages: first one is if the person doesn't wear the helmet the vehicle won't start. This will be possible by using sensor in the helmet by detecting whether driver has wear the helmet or not. Drinking and Driving is against the law but still people don't follow it, which leads to damage to their lies as well as other too. So, the second most important advantage of smart helmet is that using sensor it will detect whether the person is drunk or not. And if the person is drunk the vehicle won't start. Therefore, smart helmet will be used for safety as well as for following the rules by government.

We will design the head lamp which will work according to the climatic condition. The head lamp will be on when light is need and it will be off when not needed.

A special type of sensor will be used in vehicle which will work according to the intensity. If an accident takes place it becomes difficult for the victim as well as his family members to known about the incident. If such type of accident happens then through GPS module a message can be delivered to victim's family members as well as nearby police station and hospital. Due to this victim can get the aid as early as possible.

To beat or to overcome these limitations, this paper shows, based methodology for two wheeler that depends upon the use of many pair of sensors. Literature lacks a study that specially focuses on to give best solution in automation of two wheeler.

## II. METHODOLOGY

In methodology we are going to explain the flow of our project, how it can be done and explain some basic idea of project. So first of all there total five modules in our project that are we implement separately. First model is regarding the footrest. In this we use one limit switch, so due to this limit switch when person sit behind the diver of two-wheeler, then the footrest is open automatically by using intensity of weight of the person who sit behind. Second module includes the smart helmet concept. In this module we use one helmet which we call the smart because it has some smart functionality such as there is one smoke detector sensor which sense that the driver of two wheeler is alcoholic or not. If that person is alcoholic then it does not allow starting two-wheeler. There is one more concept which is mainly most important that is if person does not wear the helmet then the two-wheeler does not start. This technique helps people to secure from the injury of head. Third module represents about the head lamp intensity. As we noticed that new active model has the head lamp which glow continuously, due to this many accident is happens now days. So to reduce this problem we use one sensor which reduce or increase the intensity of that head lamp according the atmospheric moisture. The fourth model includes the concept regarding the side stand. We see in our surrounding the people forget to close the side-stand. We noticed the accident happens when that stand stuck to any stone or road. So reduce this problem we are going to implement the concept that if in case the side stand is remains open then the two-wheeler does not start. The last module includes the concept of accident. When accident happens the injured people does not get help instantly. So we use one sensor which calculates the intensity of accident and then message to nearest police station, hospital and registered mobile number of parents. The below data flow diagram give us the rough idea of our project.

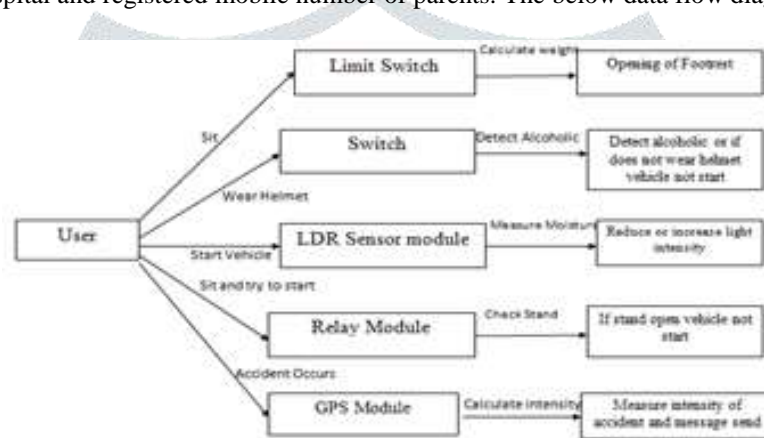

Fig: data flow diagram

## III. COMPONENT

### 3.1 Raspberry Pi3

- It has built in Wi-Fi and Bluetooth.
  - Latest product
  - 1GB SDRAM
  - 2.4 GHZ and 5GHZ IEEE 802.11
  - Bluetooth 4.2
  - Extended 40 pins GPIO header
  - 4 USB 2.0 ports
  - CSI camera port
  - DSI display port (touch screen display)
  - Video port
- ✓ Hardware In Raspberry Pi3:
- Schematics
  - BCM28 35
  - Boot modes
  - Power
  - USB
- ✓ Accessing Remotely:
- IP Address
  - Access over Internet
  - FTP
  - SFTP
  - Web server

- ✓ Official Programming Language of Raspberry Pi3:
  - CDLES
  - Python
  - HTML
  - Java
  - C++
  - C
- ✓ Android Run on Ram and Raspberry Pi
- ✓ Uses:
  - TV Box
  - File server
  - Retro gaming
  - Desktop Computer



*fig. raspberry Pi3*

### 3.2 Proxy Sensor

- Sensor can sense the objects which is present near to sensor without any physical contact.
- It releases an electromagnetic beam or field.
- It returns signal or detect changes happen in field.
- Types: Infrared Proximity sensor, optimal proximity in Samsung mobile.
- Example: Parking sensors.

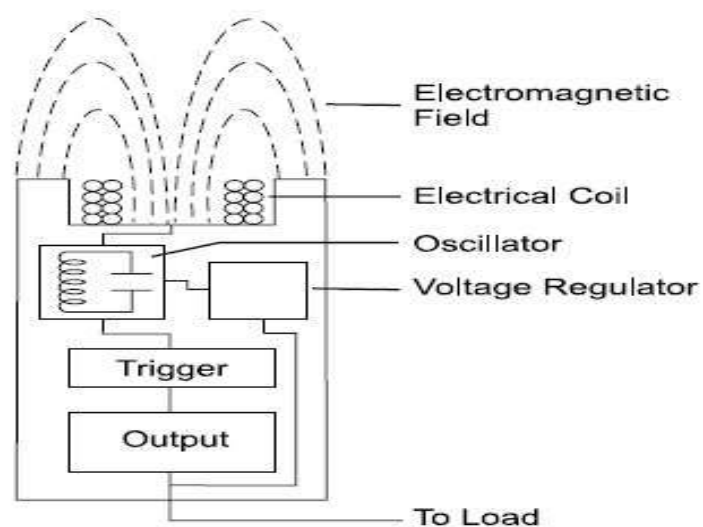

*fig. proximity sensor*

### 3.3 Limit Switch

- It is an electro mechanical device which consists of an actuator mechanically connected to a set of contacts.
- To make or break electrical connection device has to operate contacts. It can possible when object and actuator are comes into contact.

Example: Controlling machinery, count objects passing points.



shutterstock.com • 515051734

*fig. limit switch*

### 3.4 LDR Sensor Model

- It used to detect intensity of light.
- Greater intensity of light lowers the LDR.
- Example: Alarm Clock.



*Fig. LDR sensor module*

### 3.5 Power Supply

- Electronic device that supplies electrical power to electrical load.



*Fig. Power Supply*

### 3.6 L293D Module

- It has a 16 pin connection motor Driver IC.



- It provide bidirectional drive currents from 5v to 36v.
- We can control two DC motor with single L293D.

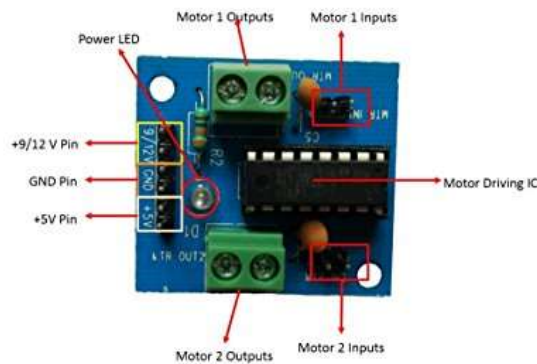

fig.L293D module

### 3.7Motor

- Is an electrical machine that converts electrical energy into mechanical energy

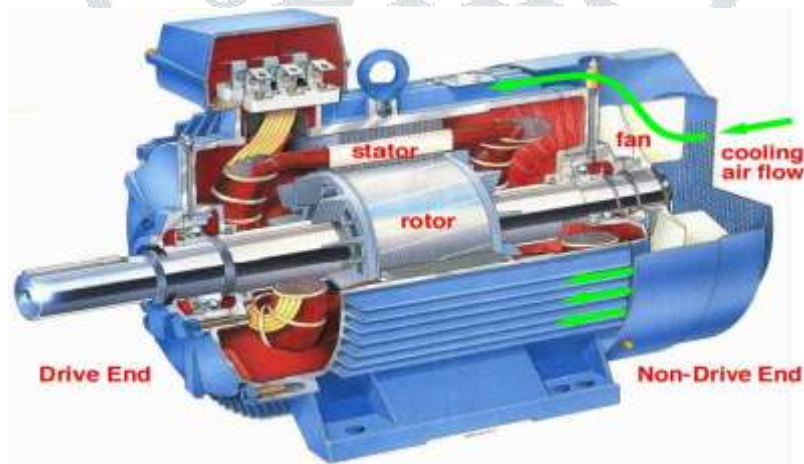

fig. motor

### 3.8GSM 900 Module

- It can be used to access the internet and for oral communication.
- It is able to connect with a microphone and small loud speaker.



fig. GSM 900 module

### 3.9GPS Module:

- To compute position GPS receivers uses a constellation of satellites and ground stations.

- Position and time can be calculated by using this information and some math a ground based receiver or GPS module.

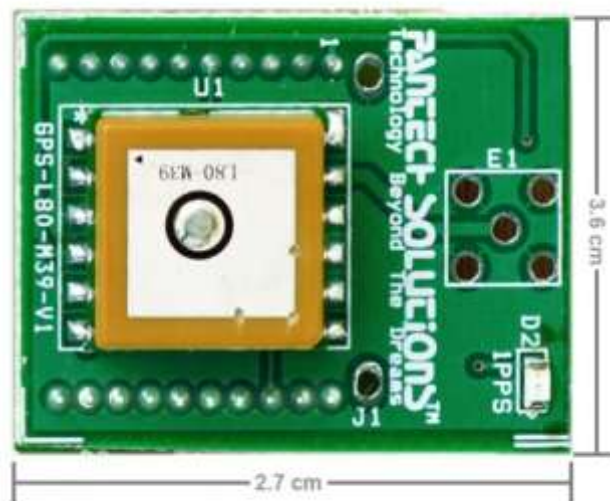

fig. GPS module

### 3.10 Relay Module

- Is an electrical operating switch.
- Used to mechanically operate switch and provide electrical isolation between two circuits



fig. relay module

### 3.11 Light

- Sterilization of water and air.



fig: light

### 3.12 Volt Battery:

- Used as portable power sources to run amplifier on outdoor situation.
- Used in small vehicles.



fig: battery

### 3.13HDMI To VGA Converter:

- To convert desktops, set-top box cable boxes and Apple TV.

### 3.14Memory Card:

- It used to for storage purpose in mobile phones as an external storage device.



Fig Memory

### 3.15Connecting Cables:

- Twisted pair Ethernet cable used to connect computing devices together directly.



fig: connecting cables

### 3.16Power Cables:

- Is an electrical cable.
- Installation of power cable is possible as permanent wiring inside buildings buried in ground.



fig: power cable

#### IV. DISCUSSION

In this project we had done one survey in which by communicating with different age group people. We found out five major problems as an output of this survey. Survey table is shown below which gives information about problems occur while travelling by two-wheeler. According to this survey there is need to provide solution to the problems occur most of the times in human life which leads to morbidity and mortality.

##### 4.1 Survey Table Regarding Project:

Sr. No.	Customer Type		Footrest Problem(Y/N)	Side Stand problem(Y/N)	Head Lamp problem(Y/N)	Helmet(Y/N)	Accident Help(Y/N)
1	Students	1	Yes	Yes	No	Yes	Yes
		2	Yes	Yes	Yes	Yes	Yes
		3	Yes	Yes	Yes	Yes	Yes
		4	Yes	Yes	Yes	Yes	Yes
2	Ladies	1	Yes	Yes	No	No	Yes
		2	Yes	Yes	Yes	Yes	Yes
		3	Yes	Yes	Yes	Yes	No
		4	Yes	Yes	Yes	Yes	No
3	Age people	1	Yes	Yes	Yes	Yes	No
		2	Yes	Yes	Yes	Yes	Yes
		3	Yes	Yes	Yes	No	Yes
		4	Yes	Yes	Yes	Yes	Yes
4	Job Persons	1	Yes	Yes	Yes	Yes	Yes
		2	Yes	Yes	Yes	Yes	Yes
		3	Yes	Yes	Yes	Yes	Yes
		4	Yes	Yes	Yes	No	Yes



**4.2 LITERATURE SURVEY:**

Sr.no	Title	Technology	Description	Limitations
1	A System for Automatic Notification and Severity Estimation of Automotive Accidents[1]	Data Mining, vehicular networks	A novel intelligent system which is able to automatically detect road accidents, notify them through vehicular networks, and estimate their severity based on the concept of data mining and knowledge inference.	People unaware about this technology.
2	A Novel Two Wheeler Security System Based on Embedded System[2]	GPS, Global System for mobile, Antitheft, Sensors, Arm7.	This paper explain us smart bike monitoring which helps to save human life and avoid robbing of vehicle.	1. Cost is not affordable.
3	Accident and Road Quality Assessment using Android Google Maps API[3]	GPS and GSM Module, Accelerometer, Androids.	Device proposed in this paper to provide additional layer or travel ease and security. With the help of open source android environment with robust hardware to increase both the ride quality and safety of the user.	1. GPS and GSM module can be removed and replace by calling through android interface. 2. The hardware can be implemented in smaller, sturdier chip design.
4	Vehicle Detection using Acoustic Signatures[4]	Acoustic signatures, feature selection, k- nearest neighbors, wavelet analysis.	Paper describe about fast and potent method for classification of vehicles is used to select the required method for classification of vehicle using k-nearest neighbors algorithm into three categories: Two wheelers, four wheeler and heavy transport vehicle.	1. All error are not remove.

**V. CONCLUSION**

This system proposed that automatic closing and opening of footrest when back sitter is on two wheeler. Sensor technology is used to know about when to open and close footrest automatic. GPS is used to track two wheeler while accident occur and message will be send to nearest police station and register contact number so accident person get immediate help. The side stand is one of the lifesaving mechanisms and it helps to prevent accidents. This system is useful to provide human safety and luxurious life.

**VI. ACKNOWLEDGMENT**

We heartily thankful to Mrs. B. A. Ahire mam who encourage us and provide necessary guidance.

**VII. REFERENCES**

- [1] Manuel Fogue, Piedad Garrido, Francisco J. Martinez University of Zaragoza, Spain, a System for Automatic Notification and Severity Estimation of Automotive Accidents, 1536-1233/13/\$31.00 © 2013 IEEE  
 [2] Prachi r. Rajarapollu, A novel two-wheeler security based on embedded system, 2016 IEEE  
 [3] Prakhar Bhatt#1, Saransh Gupta#2, Prateek Singh#3 Preeti Dhiman\*4, Accident and Road Quality Assessment using Android Google Maps API, ISBN: 978-1-5090-6471-7/17/\$31.00 ©2017 IEEE  
 [4] M Uttarakumari1, Anirudh S Koushik2, Anirudh S Raghavendra3 , Vehicle Detection using Acoustic Signatures, ISBN:978-1-5090-6471-7/17/\$31.00 ©2017 IEEE