

Spray Pyrolysis Deposition and Structural Characterizations of Lithium Ferrite Thin Film

Rahul R. Chilwar¹, H. J. Kardile², S. R. Nimbore³, M. K. Babrekar⁴, K. M. Jadhav⁵

¹Department of Physics, Yogeshwari Mahavidyalaya, Ambajogai, Beed, India (MS)

²Arts, Commerce and Science College, Sonai, Nevasa, Ahmednagar, India – 414602

³Department of Physics, Arts, Commerce and Science College, Ashti, Beed, India (MS)

⁴Department of Physics, Indraraj College of Arts, Science and Commerce, Sillod, Aurangabad, India (MS)

⁵Department of Physics, Dr. Babasaheb Ambedkar Marathwada University Aurangabad, (MS), 431004

Abstract: Nanocrystalline lithium ferrite thin film was deposited on ultrasonically cleaned glass substrate by spray pyrolysis deposition technique. Lithium nitrate and ferric nitrate were taken as a raw material and in 1:5 molarity ratios. The glass substrate on which the film is deposited was preheated at temperature 375°C. The deposited film was annealed at 550°C for 4 h. The annealed film was characterized by X-ray diffraction method for structural analysis. The crystallite size calculated from Debye-Scherrer's formula found to be 16 nm which confirms the nanocrystalline nature of the prepared thin films. The lattice constant calculated by standard relation was found to be of the order of 8.333 Å. The X-ray density was found to be 5.382 gm/cm³. The obtained values of lattice constant and X-ray density are in the reported range.

Index Terms - Spray pyrolysis; Lithium ferrite; X-ray diffraction

I. INTRODUCTION

Ferrites are the magnetic ceramics usually consists of iron oxide Fe₂O₃ and metal oxide MO. Metal oxides can be of transition metal group viz. Co, Ni, Zn etc. They possess very good electrical and magnetic properties simultaneously and therefore they are of prime importance to scientist and technologist. They possess very high electrical resistivity, low eddy current and dielectric losses and high saturation magnetization [1-2]. On account of their excellent electrical and magnetic properties they find application in various fields such as electronics, optoelectronics, electrical, automobile etc. These electrical and magnetic properties of ferrites are dependent on method preparation, type and amount of dopant and distribution of cations over the available sites [3]. The ferrite in bulk, nano and thin film form can be prepared by several techniques and each class has different applications in different fields [4]. Recently, ferrite thin films with nanocrystalline nature are of current interest to the researchers. The ferrite thin films can have applications in various fields such as gas or humidity sensors, etc [5-6].

In the family of ferrites, spinel ferrites namely lithium ferrite is a unique ferrite possessing many interesting properties. These properties of spinel ferrites thin films mostly depend on deposition techniques [7]. The deposition techniques are classified into physical and chemical methods. Chemical methods are most convenient for the deposition of thin films compared to physical method. Spray pyrolysis is one of the best chemical methods for the deposition of spinel ferrite thin films [8]. In the present work, we report the deposition of lithium ferrite thin films using spray pyrolysis technique by optimizing all the necessary parameters and structural properties obtained through X-ray diffraction technique.

II. EXPERIMENTAL METHOD

The raw materials such as lithium nitrate and ferric nitrate [Fe(NO₃)₃.9H₂O] AR grade were used for deposition of lithium ferrite thin films without further purification. Lithium ferrite thin film was deposited on glass substrate by spray pyrolysis deposition technique. The stoichiometric amount of respective metal nitrates was dissolved in distilled water and mixed together for spray. Lithium ferrite thin films were prepared by spraying the solution onto previously cleaned glass substrate. Glass substrates mounted on a holder were placed on the surface of a hot plate. A temperature controller was used to hold the preset temperature of 350°C with an accuracy of ± 5°C through a chromel-alumel thermocouple connected to the glass substrate. A prepared solution was atomized in air via pneumatic spray system under an air pressure of 2 kg/cm². The atomized droplets were transformed onto the heated glass substrate for 0.5 sec intermittently. The substrate temperature could be reduced under the effect of spray and requires several seconds to recover the preset temperature. The solution spray rate and the distance between nozzle and substrate were kept constant at 0.125 ml/s and 30 cm respectively. The films were annealed at a temperature of 550°C for 4 hours. The optimized parameters are tabulated in table 1. The schematic of spray deposition is shown in Fig. 1. The deposited films were characterized by X-ray diffraction method (XRD) in the 2θ of 20° to 80° at room temperature

Table 1: optimized parameters for thin film deposition

Solution Concentration	1:5 M
Volumetric ratio	1:1
Deposition temperature	350°C
Annealing temperature	550 °C for 4 h
Distance between substrate to nozzle	28 cm
Spray rate	1.5 ml /min
Air pressure	0.25 MPa

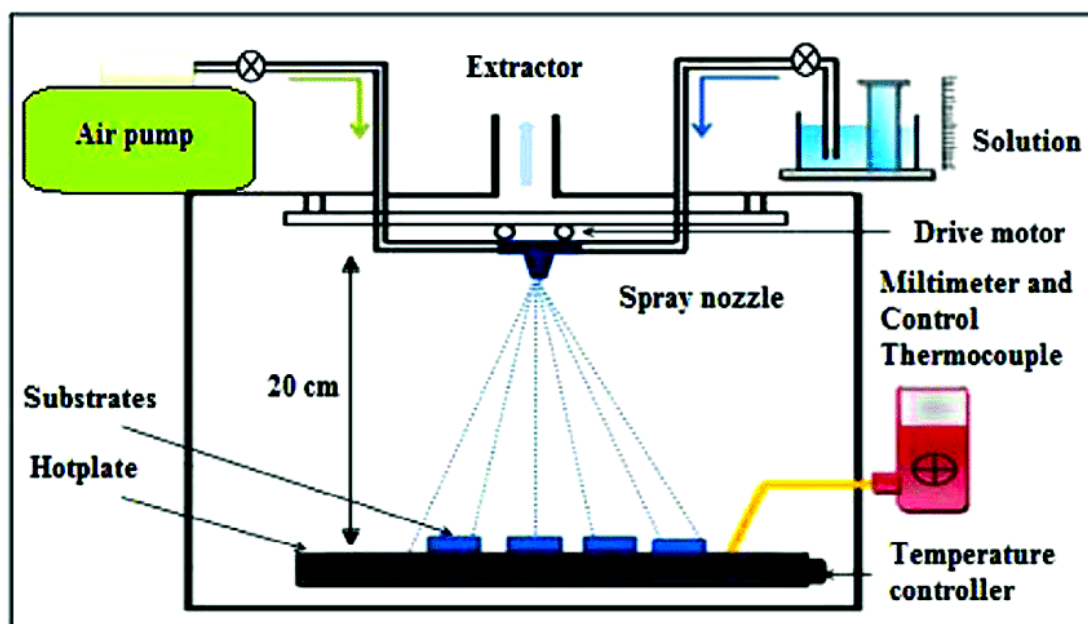

Fig. 1 Schematic of spray deposition

III. RESULTS AND DISCUSSION

Fig. 2 depicts the X-ray diffraction (XRD) pattern of lithium ferrite thin film. The XRD pattern revealed good crystallinity because of annealing of the film. The lithium ferrite film is oriented along (311) plane. The other planes viz. (210), (310), (311), (421), (422) (511) (440) and (441) also exist in the XRD film which is sharp and intense. The XRD patterns matches well with the characteristics reflections of cubic spinel structure. The analysis of XRD pattern revealed the formation of single phase cubic spinel structured lithium ferrite thin film. The interplanar spacing (d) values of the film are in good agreement with the standard (d) value of lithium ferrite. Using the (d) values and corresponding Miller indices, the value of lattice constant of the lithium ferrite thin film was evaluated. The value of lattice constant ‘a’ is given in Table 2 which is in good agreement with the reported value. The value of ‘a’ was used to obtain the unit cell volume, X-ray density, and are given in Table 2.

The crystallite size was determined from full width of half maximum (FWHM) of the most intense (311) peak, which was obtained by slow step scanning or on that peak at 0.20 per minutes based on Scherrer’s formula Debye-Scherrer formula for crystallite size determination is given by

$$D = \frac{0.9 \lambda}{\beta \cos \theta} \quad \dots 1$$

where, D is the crystallite size, λ is the wavelength of X-ray, β is the full width at half maximum (FWHM) after correcting the instrument peak broadening (β expressed in radians), θ is the Bragg’s angle. The crystallite size is of the order of 27 nm, which indicates the nano-crystalline nature of the film. The value of crystallite size is given in Table 2.

Table 2 Lattice parameter (a), Unit cell volume (V), Crystallite size (t) and X-ray density (d_x) of lithium ferrite thin film

a (Å)	V (cm ³)	dx (gm/cm ³)	t (nm)
8.333	578.63	5.3802	27

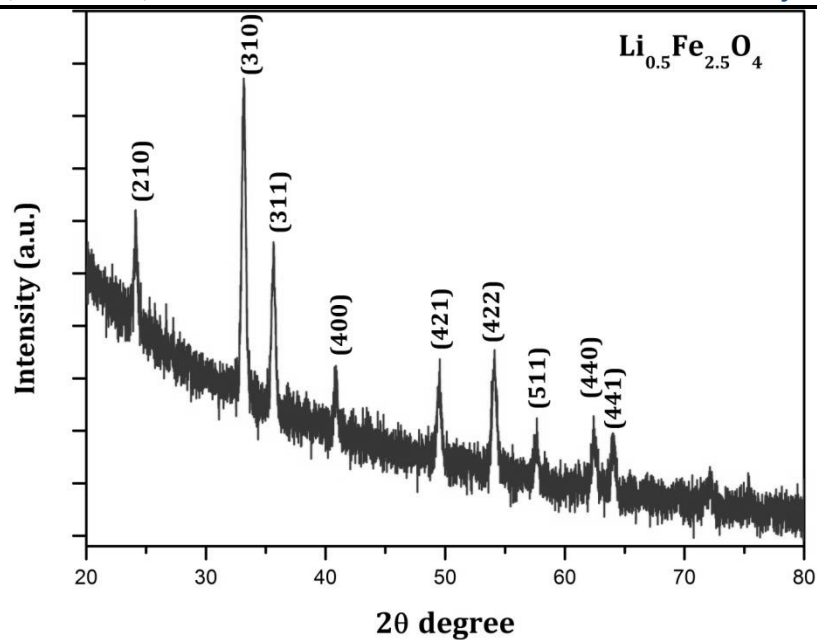

Fig. 2 The X-ray diffraction pattern of lithium ferrite thin film

IV. CONCLUSION

Nanocrystalline thin film of lithium ferrite has been successively deposited on glass substrate using spray pyrolysis technique. X-Ray diffraction analysis proves that, the film possess simple cubic spinel structure. The crystallite size was found to be 27 nm, which confirms the nanocrystalline nature of prepared lithium ferrite thin film.

REFERENCES

- [1] G.-L. Sun, J.-B. Li, J.-J. Sun, X.-Z. Yang, *Journal of magnetism and magnetic materials*, 281 (2004) 173-177.
- [2] R. Kambale, P. Shaikh, S. Kamble, Y. Kolekar, *Journal of Alloys and Compounds*, 478 (2009) 599-603.
- [3] M. Sertkol, Y. Köseoğlu, A. Baykal, H. Kavas, A. Bozkurt, M.S. Toprak, *Journal of Alloys and Compounds*, 486 (2009) 325-329.
- [4] K. Gheisari, S. Javadpour, H. Shokrollahi, B. Hashemi, *Journal of Magnetism and Magnetic Materials*, 320 (2008) 1544-1548.
- [5] A. Manikandan, M. Durka, S.A. Antony, *Journal of Superconductivity and Novel Magnetism*, 27 (2014) 2841-2857.
- [6] J.M. Coey, *Magnetism and magnetic materials*, Cambridge University Press, 2010.
- [7] A. Costa, E. Tortella, M. Morelli, R. Kiminami, *Journal of magnetism and magnetic materials*, 256 (2003) 174-182.
- [8] N. Gupta, A. Verma, S.C. Kashyap, D. Dube, *Journal of Magnetism and Magnetic Materials*, 308 (2007) 137-142.