

Automatic Solar Tracker and Auto Intensity Robot

Y.Muralimohanbabu¹, V.Harinath², Y.Ishwarya³, S.Lakshmi⁴, T.Jashuva⁵

Professor¹, U.G.Student^{2,3,4,5},

Department of Electronics and Communication Engineering
SITAMS, Chittoor, Andhra Pradesh, India.

ABSTRACT

Energy crisis is the most prior issue in today's world. Renewable energy resources are drastically increasing its priorities in the whole world. Solar energy is constantly gaining the attention as an main means of expanding renewable energy sources. Solar cells convert energy from sun into electrical energy which is costly and inefficient. Different mechanisms are applied to increase the efficiency of the solar cell to reduce the cost. Automatic solar tracking system is the most common technology to increase the efficiency of the solar cells by tracking the sun. With the implementation of the proposed system the additional energy generated is around 25% to 35%. This design methodology is based on the micro controller ATmega328p. The prime sensor generally used in solar systems is Light Dependent Resistors (LDR's). The designed automatic solar tracker has the control of mechanism which will provide three ways of controlling system. The energy generated from the panel can be used for LED (Light Emitting Diode) based street lights with an auto intensity control that uses solar energy from photo voltaic cells.

Keywords: Intensity, tracking, solar, robot

I. INTRODUCTION

Energy and power are the main factors for the development of our civilization. An huge amount of energy is extracted, distributed, converted and consumed to the global society daily. A amount of 85% of energy production depends upon fossil fuels. To provide a sustainable power production and safe world to the future generation, there is always growing demand for energy from renewable sources like solar, wind, etc.

The sun is the prime source of vitality, directly or indirectly way, which is additionally the fuel for most inexhaustible systems. Among every single sustainable system, photovoltaic cells is the one which has an incredible opportunity to supplement the customary vitality assets. Sun powered board directly changes over sun radiation into electrical vitality. Solar boards are basically produced using semiconductor materials. The best way to improve the emitted energy is to expand the power of light falling on it. Sun oriented trackers LDR's are the most fitting innovation to expand the productivity of sunlight based boards through keeping the boards lined up with the sun's position.

In this task the approach of a microcontroller incorporated basic and effectively modified. Photovoltaic cells are the essential of the close planetary system. The word photovoltaic originates from "photograph" signifies light and "voltaic" signifies creating power directly from daylight. The yield intensity of a photovoltaic cell relies upon the measure of light anticipated on the cell. Time, season, board position and introduction are likewise the variables behind the yield control. Photovoltaic cells are the littlest piece of a solar board. Solar board gives greatest power yield when sun is directly lined up with the board.

To get maximum efficiency, the solar board panel must remain in front of the sun for whole day. It is totally programmed and keeps the board before the sun until that is normal. The one of a kind component of this framework is that as opposed to accepting the earth as in its reference, it accepts the sun as a managing source. Its dynamic sensors always screen the daylight and turn the board towards the light source where the force of daylight is most extreme.

II. METHODOLOGY

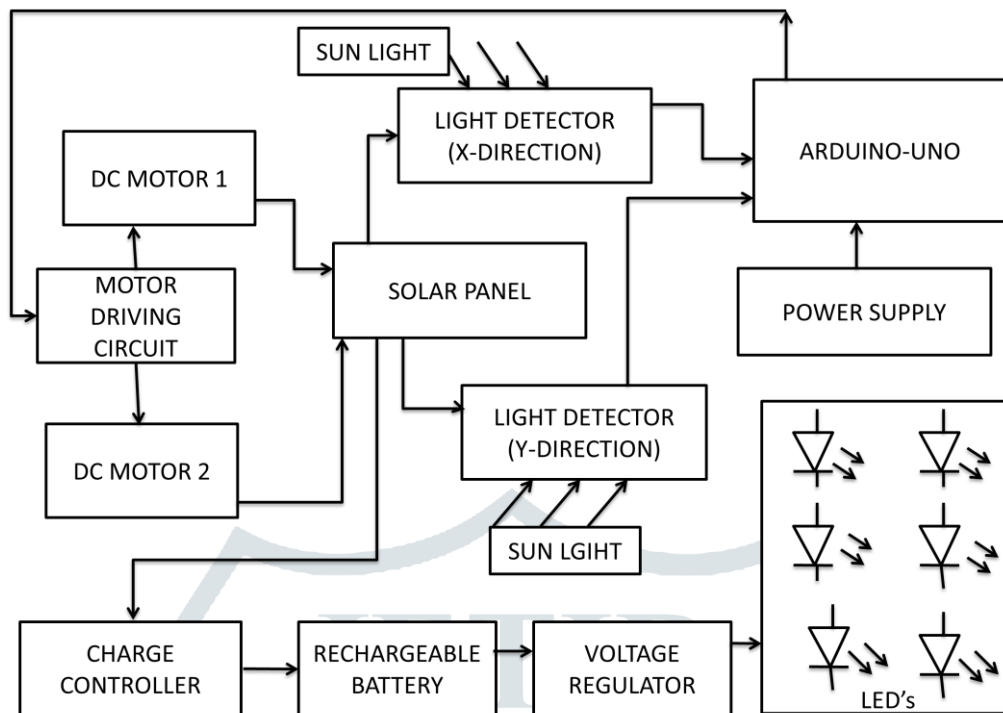

Fig 1: Block Diagram of Automatic Solar Tracker and Auto Intensity Control

In the past we don't have any automatic technologies for rotating the solar panel. It was not provided sufficient output continuously. It is difficult to rotate solar panel every time on the day manually at a plant. So power is not sufficient for all the time.

A solution for this drawback of the manual controlling of the solar panel direction is microcontroller based two-axis solar tracking system. In this system, we have LDR's for changing the direction of the solar panel according to sunlight.

It is totally programmed and keeps the board before the sun until that is noticeable. The remarkable element of this framework is that as opposed to accepting the earth as in its reference, it accepts the sun as a managing source. Its dynamic sensors continually screen the daylight and turn the board towards the heading where the force of daylight is most extreme.

There is an input of the voltages from the two LDRs. The inputs are analog. They are converted to digital values that range between 0-1023. The two digital values are compared by the comparator and the difference between them obtained. Then the microcontroller takes the decision according to the program for rotation of the DC motor. If the LDR voltages are the same, the DC motor stops the action. Otherwise, the DC motor rotates according to the intensity of sunlight.

The inputs into the system are the two LDR voltages into pins 23 and 24 of the microcontroller Arduino Atmega328. There is then the conversion of the analog voltages into their digital values. The larger value of the two signals is sent to the circuit which drives

The generated energy from the solar panel is used to control the light intensity from sunrise till sunset based on the brightness. LED street lights are better compared to traditional street lights. Because, this solar-powered street lights can conserve a large amount of electricity compared to the other lights, which are light in weight to their maximum intensity at all times.

III. RESULTS AND DISCUSSIONS

This document is an output of the project that is constructed using a balanced concept that consists of comparing three signals from the sensors. Resistance dependent on light as light sensor has been used. For the driver circuit, the microcontroller acts as a brain that controls the movement of the motor through the motor controller. The microcontroller will send data to the bidirectional DC motor and the motor controller circuit controls the rotation of the motor to rotate east or west.

When LDR-2 receives more light than LDR-1, it offers lower resistances than LDR1, which provides a high input to comparators A1 and A2 on pins 4 and 7, respectively. As a result, the pin1 output of the comparator A2 is raised to rotate the motor M1 in one direction and the solar panel rotates

At the point when LDR-1 gets more light than LDR-2, it offers lower resistance than LDR-2, giving a low contribution to comparator's A1 and A2 at pins 4 and 7, respectively. As the voltage at stick 5 of the comparator A1 is presently higher than the voltage at its stick 4, its yield stick 2 goes high. Accordingly the engine M2 pivots the other way and the sunlight based board turns. What's more, the produced energy from the solar-powered board is utilized for light in the roads.



Fig 2: Top View of Automatic Solar Tracker and Auto Intensity Control

The above figure is the top perspective on the sun powered tracker, and the board is in stable position it won't pivot to east or west headings. Since the light falls on the two sensors (LDR's) is same. Here the solar-powered board is constrained by the microcontroller with the assistance of motor.

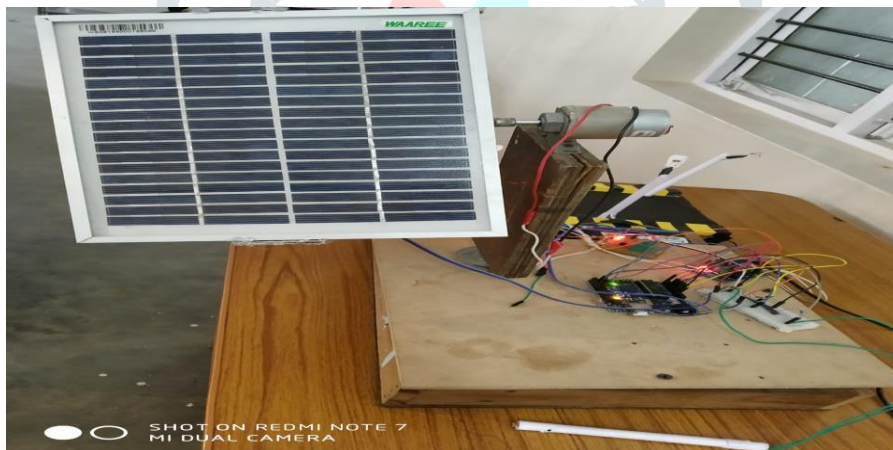

Fig 3: Rotation of Automatic Solar Tracker and Auto Intensity Control to East Direction

The solar panel rotates to east direction only when there is maximum light intensity falls on the LDR sensor at the east direction. At this time the light intensity on the LDR at west direction is low.

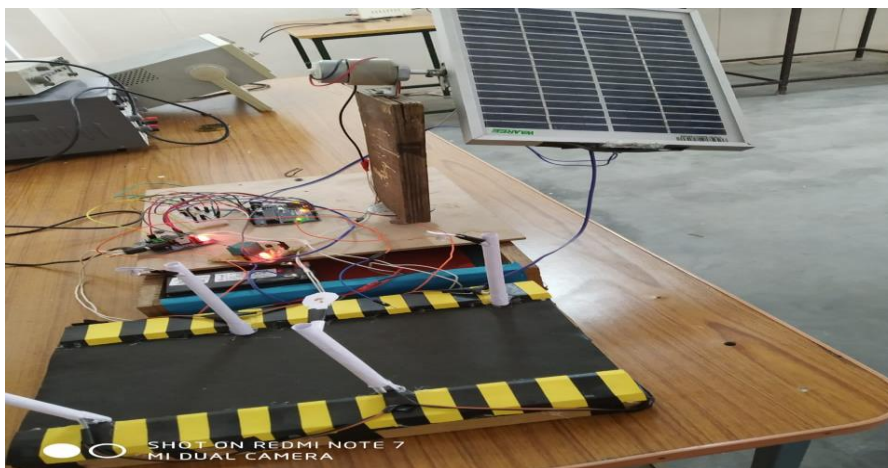

Fig 4: Rotation of Automatic Solar Tracker and Auto Intensity Control to West Direction

The above figure demonstrates revolution of sun based board to west course. Since the light power falls on the sensor at the west heading is more contrasted with east. The power esteems from the sensors are simple and contrasted and the assistance of comparator circuit, which is incorporated in the microcontroller Arduino ATmega328.

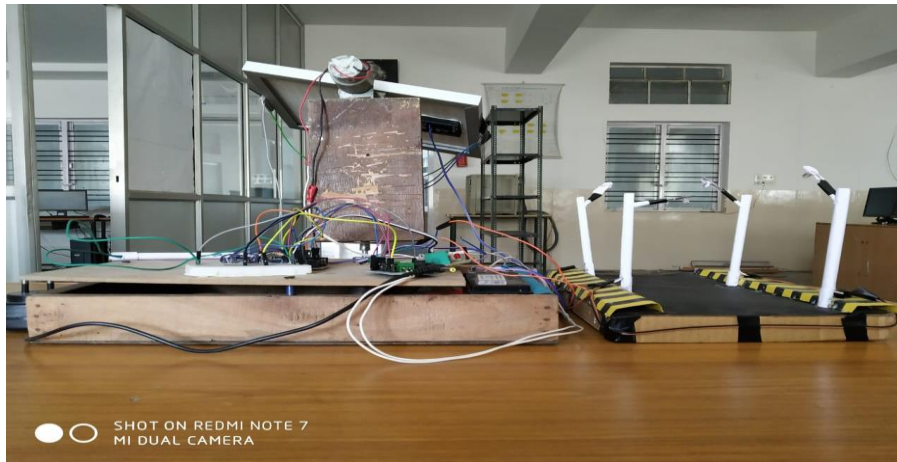

Fig 5: Side View of Automatic Solar Tracker and Auto Intensity Control

The above figure shows side view of the solar tracker when it is in running position. And the rotation of the panel is depends on the light intensity falls on the sensors.

IV. CONCLUSION

This paper is based on automatic solar tracker and auto intensity control is cost-effective, eco-friendly and the safest way to save energy. It is clear that the world is facing two major problems those are saving of energy and disposal of incandescent lamps, very efficiently. The system designed is that 25 to 30% of more energy conversion than the existing static solar module system.

LEDs have a long life, emit cool light, and can be used for fast switching. For these reasons, our concept presents farm ore advantages which can overcome the present limitations. The lamps will turn “ON” immediately when the sunset the lights go “OFF” once the illumination exceed. With this design, the drawback of the streetlight system using a timer controller is overcome and human intervention is completely eliminated. By this energy consumption and cost are drastically reduced.

REFERENCES

- [1] K. Saxena and V. Dutta, "A versatile microprocessor-based controller for solar tracking,
- [2] T.A. Papalias and M. Wong, "Making sense of light sensors," <http://www.embedded.com>,
- [3] R. Condit and D. W. Jones, "Simple DC motor fundamentals," Texas Instruments. Publication AN907, 1 – 22, 2004.
- [4] S. J. Hamilton, "Sun-tracking solar cell array system," University of Queensland Department of Computer Science and Electrical Engineering, Bachelors Thesis, 1999.
- [5] Murali Mohan Babu Y, Subramanyam MV, Giriprasad MN. A New Approach For SAR Image De-noising. International Journal of Electrical and Computer Engineering, Volume 5, Issue 5, 984-991, October 2015.
- [6] Murali Mohan Babu Y, Radhika K. A new approach for microwave imagery de-noising. International Journal of Image, Graphics and Signal Processing, Volume 5, issue 1, 52-60, May 2016.