

PCB FAULT DETECTION USING IMAGE PROCESSING

Rahul Dongare¹, Mahesh Anerao², Sapna Borolkar³, Prof. S.P. Gopnarayan
Dept. of Electronics and Telecommunication,
All India Shree Shivaji Memorial Society's Institute of Information Technology.

Abstract-The importance of the Printed Circuit Board inspection process has been magnified by requirements of the modern manufacturing environment where delivery of 100% defect free PCBs is the expectation. To meet this expectations, identifying various defects and their types becomes the first step. In this PCB inspection system the inspection algorithm mainly focuses on the defect detection using the natural images. Many practical issues like tilt of the images, height at which images are taken etc. are to be considered to ensure good quality of the image which can then be used for defect detection. The forming of printed circuit board (PCB) is a multidisciplinary process, and etching is the most critical part in the PCB manufacturing process. In order to reduce scrap produce by the wrongly etched PCB panel, inspection has to be done in early stage. In this paper a method to identify the defects in natural PCB images and related practical issues are send using Software tools and some of the major types of single layer PCB defects like Track cut, Pin hole, Track short etc., Therefore the defects should be identified before the etching process so that the PCB would be reprocessed. In the present to reach expected to improve the output of the system in detecting the defects even in low quality images.

Introduction-Printed circuit board (PCB) is a mechanical platform of conductive and non-conductive layers on which electronic components are electrically connected. Etching is one of the process in the PCB fabrication where in unwanted metallic portion occur in places other than the designed pattern is removed. If the PCB defect are still present in the post etching process at that time the PCB's are considered as scrap and discarded as they are unfit to used. Most of the inspection are done at the later stage and makes the etching process a most critical part in the PCB fabrication in terms of cost, time and scarp. In order to reduce

the cost and scrap in the PCB fabrication process, the inspection is to be done at the early stage. One solution for this is to use the image processing techniques for the inspection. There are several neuron models, network architectures and learning algorithm and this paper presents about RBF neural network. In a neural network, the hidden units form a set of "functions" that compose a random "basis" for the input patterns and these functions are called radial basis functions. RBF networks are took for getting a much shorter training period, but they have the disadvantage of requiring good coverage of the input space by radial basis functions. If RBF neural network were trained by excessive redundant information, network training will be overloaded, training time will be increased, and even the network generalization ability will be reduced. This report describes RBF neural network based on consistency judge for selection to find the best subset of features that not only increase the classification accuracy but reduces the number of features.

Literature survey-In 2015 [3] Sonal D. Kalro and Meghashree B.S. proposed a technique which uses referential pixel based approach. An arithmetic and logic operation between images is a pixel by pixel transformation. It produces an image in which each pixel derives its value from the value of pixels with the same coordinates in other images. But this process only used for the bare PCB, it didn't uses the assembled PCB. In 2017 [1] Jitenra P R Nayak proposed an algorithm of global edge detection which can obtain the whole edge using adaptive smooth filter algorithm selects local arc (instead of whole edge)

detection method for edge extraction local edge detection uses distance weighted average method and k-average method to overcome the effect of on clustering.

Methodology:

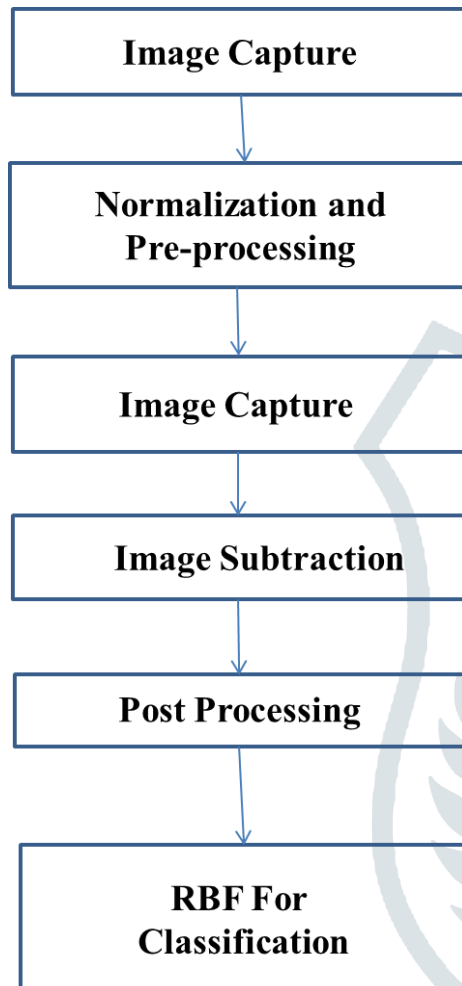

1. **Image Capturing:** In this section the camera capture the image, which is used for production line.

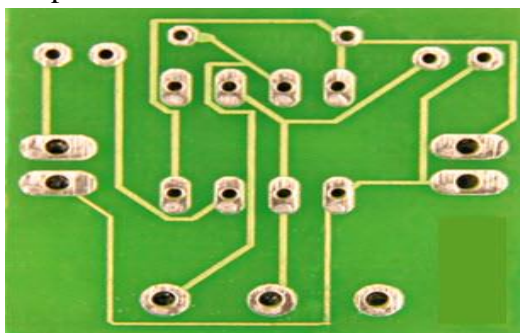

2. **Normalization and pre-processing:** In this section image captured by camera is normalized and that normalized image pre-processed if the image is was captured

with light intensity then the processing done .

3. **Image subtraction:** Image subtraction or pixel subtraction is a process the digital numeric value of one pixel or whole image is subtracted from another image. this is done for one of the two reasons –levelling of uneven image section such as half an image having a shadow on it, or detecting changes between two images..
4. **Post Processing :** The main objective of this process is focus on digital image processing .In this post processing techniques use like filter and change detection in this chapter we use the median filter witch is improves the quality of captured image and removes the unwanted pixels.
5. **RBF for classification:** Classification using artificial neural network. A Radial Basis Function Network (RBFN) is a type for neural network. Here we will be describing its use as a non-linear classifier. Generally, neural networks or “Artificial Neural Networks” are referring to the Multilayer Perceptron (MLP). Each neuron in an Multilayer Perceptron takes the weighted sum of its input values. That is, each input value is multiplied by an coefficient, and the results are all added together. A single Multilayer Perceptron neuron is a simple linear classifier, but complex non-linear classifiers can be built by combining these neurons into a network.

The RBFN approach is more intuitive than the Multilayer Perceptron. An RBFN performs classification by measuring the input’s similarity to examples from the training set. Each RBFN neuron stores a “prototype”, which is just one of the examples from the training set. When we want to classify a new input, each neuron computes the Euclidean distance between the input and its prototype. Roughly speaking, if the input more closely

resembles the class a prototypes than the class B prototypes, it is classified as class A. The above illustration shows the typical architecture of an RBF Network. It is an input vector, a layer of RBF neurons, and an output layer with one node per category or class of data.

Brand	Logitech
Series	C270
Colour	Black
Item Hight	18.1Centimeters
Item Width	5.2 Centimeters
Item Weight	222g
Product Dimensions	13x5.2x18.1cm

Fig.3

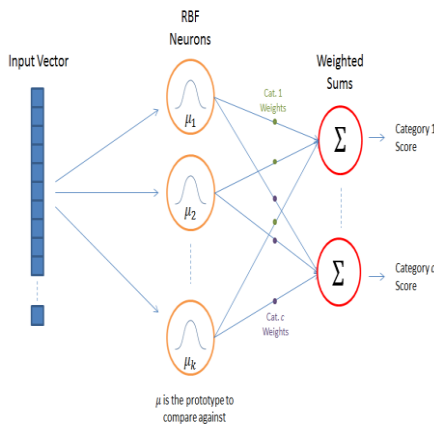

In this project we used this USB camera for capture a live pcb image. That captured image is given to the PC using Graphical User Interface with Matlab Image Processing Software installed in that PC.

PCB Database: In pcb database some Production data base is stored for the comparison. this data base is stored in PC. when the production is started the that product data base is loaded in PC and Matlab Software.

Hardware and Framework :

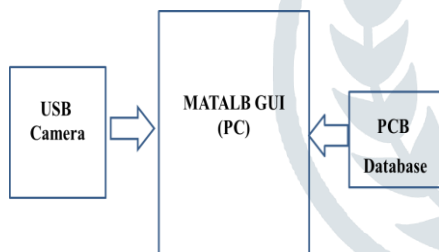

Matlab (GUI): Image processing software is matlab with GUI. In this project the camera capture the live image and PCB database is stored in file, and both information given to image processing software .It compare captured image with live image, and gives result. In the matlab image processing software converting from original image to binary and from binary to gray, this term is more important.

1.USB Camera:

The proposed system is based on image processing, we have chosen for capture live image high resolution Logitech webcam (USB Camera). this is more compatible for this project. A Webcam is generally connected by a USB cable, or similar cable, or built into computer hardware.

Web camera known for their low manufacturing cost and their high flexibility. High resolution webcam offering 1280X720p or 1920X1080p resolution.

Expected Result: This system using image processing should perform various operation on PCB image and detect all the possible major faults such as, detecting if the particular component is missing or if any two tracks are touching each other also detecting if hole is missing. After detecting all the faults system should use artificial neuralnetwork to categorise PCBs in the form of level of their faults.

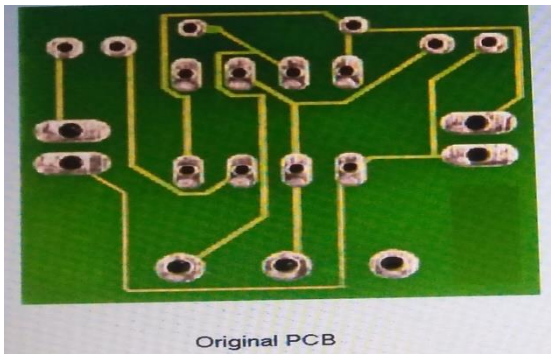
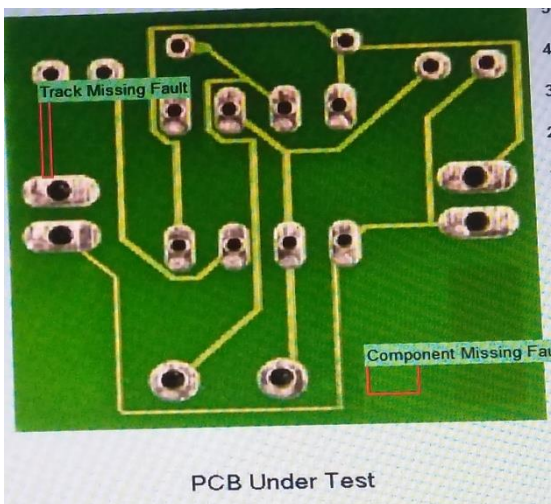
Fig.5 –Original Image**Fig.6-captured and compared image****ACKNOWLEDGMENT:**

On the very beginning of our project, we would like to extend our sincere and heartfelt recognition towards all the distinguished who have helped us in this journey. Without their help, we could not made any special act in the project. We are indebted to our Principal Dr. P. B. Mane and our beloved H.O.D Mrs. M. P. Sardey, for their guidance and endowment to conclude this project. We would also like to extend our heartfelt gratitude to our beloved guide Mrs. S. P. Gopnarayan for his valuable guidance throughout the course. We extend our gratitude to AISSMS IOIT, PUNE for giving us this opportunity. Any omission in this brief acknowledgment doesn't mean lack of gratitude.

References:

1. Jithendra P R Nayak, Parameshachari B D, K M SunjivSoyjaudah and ReshmaBanu

“Identification of PCB Faults using Image Processing” IEEE 2017.

2. RongliLiu , Xuedong Xue and Kan Cheng “Design Of PCB Detection And Diagnosis System For A Type Of Ballistic Missile Based On Embedded Technology” IEEE 2015.
3. KaurKamalpreet* KaurBeant “PCB Defect Detection And Classification Using Image Processing” International Journal of Emerging Research in Management & Technology ISSN: 2278- 9359 (Volume-3, Issue-8) 2014.
4. SitiHazurahInderaPutera, SyahrulFahmiDzafaruddin and MaziahMohamad, “MATLAB based defect detection and classification of printed circuit board,” in Digital Information and Communication Technology and it's Applications (DICTAP), 2012 Second International Conference on IEEE, pp. 115–119.
5. Jagadish S. Jakati and Sidramayya S. Matad, “PCB defect detection based on pattern matching and segmentation algorithm,” International Journal of Advanced Research in Computer and Communication Engineering, vol. 3, no. 9, Sep. 2014.