

SOPHISTICATED APPROACH IN IMPLEMENTING AUTOMATIC CONTROL OF ELECTRIC DEVICES USING 555 TIMER

¹Ganderu Usandra Babu, ²Bhukya Eswari, ³Bonam Mani Kumar,

¹Assistant Professor, ²3rd Year B.Tech, ³3rd Year B.Tech

¹Department of Electronics and Communication Engineering,

¹Lingayas Institute of Management and Technology, Vijayawada, India.

Abstract: In this project we elaborated the usage of 555 timer in conjunction with PIR sensor in constructing an electronic device where in the PIR sensor will be working as a motion detector, which detects a moving object such as a human being, the radiation emitted by the human body is detected by PIR sensor, and the sensor generates voltage proportional to human body radiations, this voltage is sent to circuit for necessary control action.

Index Terms – 555 Timer, PIR sensor, R-C network,

1.0 INTRODUCTION

Automation is an important aspect in industrial and house hold applications as well. Automatic control of electric devices has become inevitable so as to save power consumption to the possible extent. There is a lot of wastage in power consumption due to lack of proper monitoring done on the power consuming devices we are using. A fan or a light may be in an on state and may be functioning without any person or a group of people actually being around the electric device. What if we have a device which automatically switches on and of the electric devices we use at our domestic places. A lot of electricity will be saved. A circuit built with 555 timer along with a suitable sensor, more precisely PIR sensor meets this requirements. This circuit may be used for security purpose also as when the load is a buzzer alarm, gets activated when trespassed by unauthorized personnel and a light indication may be produced if the load is a light source.

2.0 HARDWARE IMPLEMENTATION

555 TIMER: IC 555 timer is a one of the most popular IC in electronics and is used in various electronic circuits for it being very much stable to temperature variations and any kind of climatic variations and also for its ease of operation. It is available in 8 DIP(Dual In-Line package).NE555 timer is preferred more generally.

Discharge: This pin is connected to the capacitor of charging unit. A 100mV voltage and a 5mA current is needed.

Vcc: The power supply can be from 5V to 18V.The power supply is connected to pin-8.

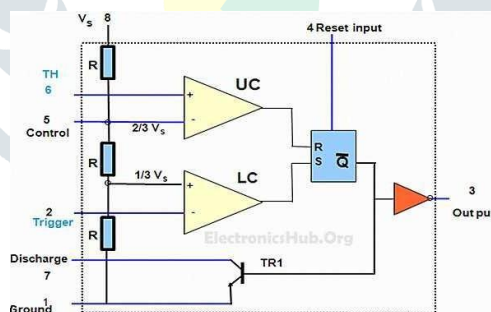

Fig.1: Internal schematic of 555 timer

POWER SUPPLY: Power supply incorporated in India is 230v, 50Hz this is converted in 9v dc by using a step down transformer in conjunction with a full wave rectifier.

PIR SENSOR:

PIR sensors are used to sense the motion. It is employed to detect the existence of any object moving around the sensor critical range. PIR sensors are used to detect the IR wavelength when a moving objects in its vicinity Sensitivity being almost 20 feet (6 meters). Power Supply: 3.3V to 5V.



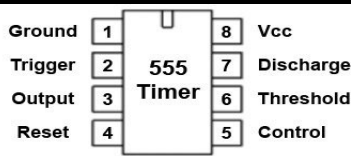

Fig3: IC-555 timer pin diagram

Ground: This pin is connected as common node, sometimes to negative terminal of the power supply.

Trigger: Pin-2 is connected to the inverting terminal of COMPARATOR. The trigger input is compared with the $1/3 V_{CC}$. In general TRIGGER pin will be at V_{CC} in normal operating conditions.

Output: The output of SR flip flop will drive the inverter and the output of the inverter will be the Output of 555 timer.

Reset: This pin drives the PNP Transistor. Usually RESET pin will be at V_{CC} (Logic 1). If RESET (Logic 0) is given to pin 4 the output of 555 timer will go to zero irrespective of the trigger input.

Control voltage: Pin-5 is connected to the inverting terminal of Comparator 1. Generally the pin voltage is at $2/3$ of V_{CC} and the pin is connected to ground through coupling capacitor (0.01uF) to suppress noise.

Threshold: This is the input to the non inverting terminal of the first comparator. The voltage that can be applied to this pin is a variable voltage between V_{CC} and ground.

RELAY: Generally RELAY is used to provide an electrical connection. The most widely used type of Electrical relay is the Electro-mechanical Relay. Relays are used to switch smaller currents in a control unit. Relay control one circuit by opening and closing contacts in another circuit.

3.0 CIRCUIT AND FUNCTIONING:

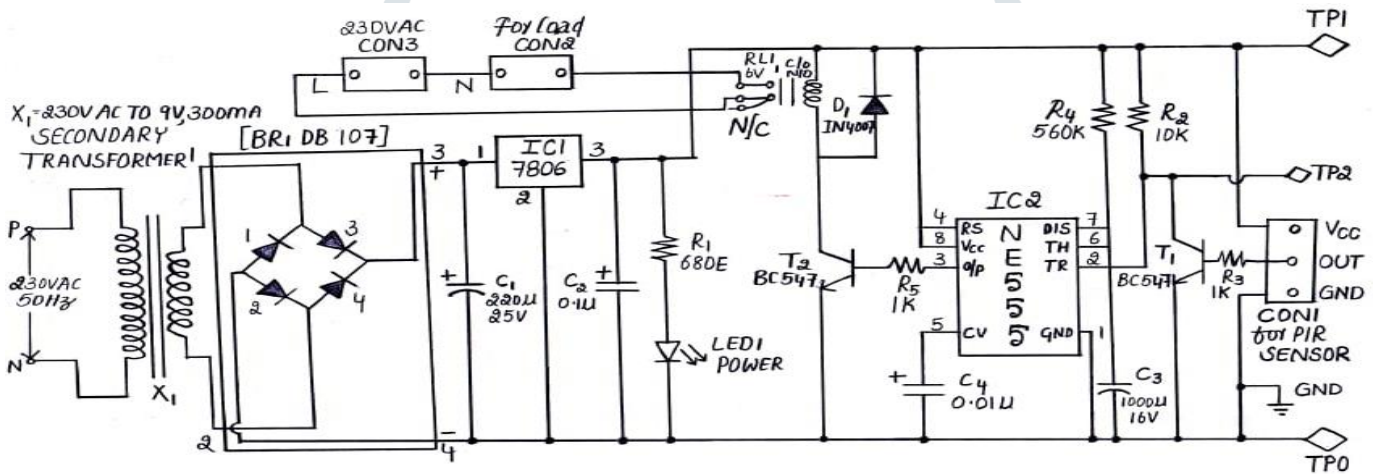

Fig4: Circuit diagram of motion sensor

The circuit diagram of automatic power control system is shown in figure. It is built around 230V AC primary to 9V, 300 milli-amperes secondary transformer, bridge rectifier, 6V voltage regulator 7806IC and few more components. The 230V AC mains is stepped down to 9V, 300 milli-amperes using a step-down transformer. This transformer output is given to a bridge rectifier with a capacitor filter to suppress the ripples existing and this in further given as input to regulator IC-7806 which in turn provides 6V regulated DC output to operate the circuit. LED is used to indicate as power on. The 555 timer is configured in mono-stable mode. In mono-stable mode of operation the circuit will have only one stable stage which is also called quasi stable state, i.e the circuit output will change its state, it may be from on state to off state or vice versa when a trigger pulse is plugged in, continues in that state for a specific predetermined time period and switches back to previous state without the need of trigger pulse again. In the proposed circuit the quasi stable state is determined by the resistor and capacitor combination connected across pin 6 and 7. By changing the resistor and capacitor values the time period of quasi stable state can be changed to desired value. Output pin-3 of 555 timer is connected to the base of relay driver transistor T2. Contacts of relay RL1 are connected to the load, which could be the user's choice. The PIR sensor used here is a pyro-electric device which detects human body infrared radiations. It has a single output that goes high when a valid motion is detected, which means the load is activated whenever the PIR sensor detects a body moving nearby.

Under normal condition, transistor T1 is in cut-off state, allowing collector output to swing high, i.e 6V in the proposed circuit. When a valid movement is detected, output pin [OUT] of the sensor goes high, allowing transistor to conduct for a certain time period, depending on the values of R4 and C3 and as required by the user. Under these circumstances, collector of transistor T1 goes low. This low signal is fed as input to IC2 which drives the output pin 3 of IC2 to high for a predetermined time period energizing the relay RL1 through transistor T2, which turns the load for certain period, which is ten minutes for the given values of R4 and C3 in the proposed circuit. Being more precise, when a human motion is detected by the PIR sensor the load gets activated and gets disabled automatically after a certain period of time. Before using the circuit the PIR sensor is connected across CON1. The transformer X1 is connected to 230V AC mains. Its suggested to ensure the various test point voltages to make sure the circuit is properly working. The test points are mentioned in the table below.

Table no.1

Test Point	Details
TP0	0V [GND]
TP1	6V
TP2	Usually high, and switches low when motion is detected

4.0 REFERENCES

[i] Robert F. Coughlin, Fredrick F.Driscoll. Operational amplifiers and linear integrated circuits (Prentice-Hall electronics,2014).

[ii] NE 555 timer datasheet, xx555 Precision Timers, texas instruments. SLFS022I – SEPTEMBER 1973–REVISED SEPTEMBER 2014.

[iii] Himani Goyal,Understanding of IC555 Timer and IC 555 Timer Tester. International Journal of Inventive Engineering and Sciences (IJIES) ISSN: 2319–9598, Volume-3 Issue-2, January 2015.

[iv] D. Roy Choudhury, Shail. B Jain. Linear Integrated Circuits (fourth edition) New Age International Publishers.

[v] D. Patranabis. sensors & transducer. 2nd edition. PHI. ISBN- 978-81-203-2198-4

[vi] Ramakanth. A. Gayakwad Op-Amps and Linear Integrated Circuits. 4th edition. ISBN-978-81-203-2058-1

