

Underground Cable Fault Detection System Using GSM & GPS

Ayush Shukla¹, Himanshu Sable², Sagar dayal Bhagat³, Ravindra⁴
1,2,3,4 Students
Department Of Electrical Engineering,
Madhav Institute of Technology and Science, Gwalior, India.

Abstract : Power cables that are used to a supply electrical power is placed underground to avoid unwanted interference. This makes it very tough to determine the exact location of the faults that occur. A fault might occur due to a many of reasons such as digging, earthquake, construction work, etc. The maintenance process related to that particular line is difficult due to unknown location of the fault in the line. In this paper, we want to present the working of a self-made hardware model illustrating the detection of faults in underground power lines using Ohm's law. The voltage drop is measured across regular intervals of the line. As soon as the fault occurs, the voltage drop across each interval varies in accordance with the Ohm's law. AT Mega 16 micro controller has been used in the hardware model. The project detects the location of fault in underground cable lines from the base station to exact location in kilometers use the micro controller kit. In metropolitan areas, the electrical cable runs in undergrounds instead of overhead lines. Whenever the fault occurs in underground cable it is tough to detect the exact location of the fault for process of repairing that particular cable. The underground fault detection system finds the exact location of the fault.

1. Introduction

The objective of this project is to develop a system for underground fault from base station in kilometers using an Arduino board. Generally we use overhead lines. We can easily detect the faults, but in populated cities we couldn't use overhead lines. So, we are moving to underground cables. Underground cables used largely in populated area rather than overhead lines. We can't easily identify the faults within the underground cables. This project deals with Arduino microcontroller, GPS, GSM, buzzer and LCD. This proposes greatly reduces the time and operates effectively. Over the time researchers have made several efforts to design and implement an electronic underground cable fault detector that will help to overcome the problems as well as challenges encountered in the use of underground cables and detection of faults that occur in the underground cables but unfortunately, there were limitations to their designs. All the above work has one limitation or the opposite. For this reason, we designed and implemented a microcontroller based underground cable fault detector that's capable of running on dual power supply i.e. AC mains and a DC battery pack, and display results on an LCD module. This is an improvement on the previous work available in literature. This design also runs on computer software program because it uses an ATmega328p microcontroller that also requires sketch or source code.

Transmission line by underground method finds its use and application over wide area. Underground cable is widely used to ensure safety. Underground cable installations are expensive as compared to overhead cable, but at the same time, it is more reliable and also the life of underground cable is more than overhead lines. This underground cables are unaffected by adverse conditions (Storm, Rainfall) and the chances for fault in underground lines are less than that of overhead lines. When the fault happens at undergrounds power cables, it is difficult to detect fault. Classification of faults in a three-phase cables are Short circuit fault, open circuit fault, Earth fault.

2. Literature Review:

Sectionalizing- This method reduces cable reliability, because it depends on physically cutting the cable. Dividing the cable into smaller sections and measuring both ways with an ohmmeter or high-voltage insulation resistance (IR) tester enabled to detect a fault in cable.

Thumping - When high voltage is delivered to faulty cable, the resulted high current arc makes enough noise to hear above ground. While this method eliminates the sectionalizing method's cutting and splicing, it has its own disadvantages. Thumping needs a current on the order of tens of thousands of amperes at voltages as high as 25 kilovolts to make an underground noise loud enough to hear above ground. The heating from this high current often causes some deterioration of the cable insulation. The limit of damage can be reduced by passing minimum required current/voltage to the faulty cable.

Time-Domain Reflectometry - The Time domain reflectometer is an instrument that uses time domain reflectometry to detect faults in metallic cables. The TDR sends a low energies signal through the cable, causing no insulation deterioration. A theoretically ideal cable returns that signal in a known time. Impedance changes in a cable changes both the time and profile, which the TDR screen graphically represents. One drawback of TDR is that it does not detect pinpoint faults.

3. Blavier Test:

When a ground fault happens in a single cable, and there is no other cable, then blavier test can be conducted to detect the fault in a single cable. In other words, in the absence of a healthy cable to locate fault in the cable measurement of resistance from one side or end is called blavier test.

Ground fault of a single cable can be detected using Blavier's test. In this type of test, low voltage supply, an ammeter and voltmeter are used in a bridge circuit.

4. Methodology:

The project uses the simple concept of Ohm's law where a low DC voltage is applied at the provider end through series resistor. The current would change depending upon the length(in km) of fault of the cable in case there is a short circuit of LL fault or 3L fault or LG fault etc. The series resistor voltage drop changes according to the fault which is then fed to an Analog to Digital Converter to develop a digital data which the programmed microcontroller would display the same in KM's. The project is fabricated with a set of resistors representing cable length in KMS and fault is generate by a set of switches at every known KM to check the accuracy of the same. This is recommended model of underground cable fault using microcontroller. It is classified in four parts –DC power, supply, cable, controlling, display part. The Part of DC power supply consist of ac supply of 230v is step down using transformer, bridge rectifier converts alternating current to direct current & regulator is used to produce constant dc voltage. The part of cable is represented by the set of resistors along with switches. Current sensing part of cable represented as set of resistors & switches are used as fault generators to show the fault at each location. This part senses the change in current by sensing the potential drop. Next is controlling part which comprises of analog to digital converter which receives input from the current sensing element, converts this voltage into digital signal and feeds the microcontroller with the signal. The microcontroller is also a part of the controlling unit and makes necessary computations regarding the distance of the fault. The microcontroller also operates a relay driver which controls the switching of a set of relays for interconnection of the cable at each phase. In case fault occur it send messages through GSM & GPS module and display on LED screen and cellphone.

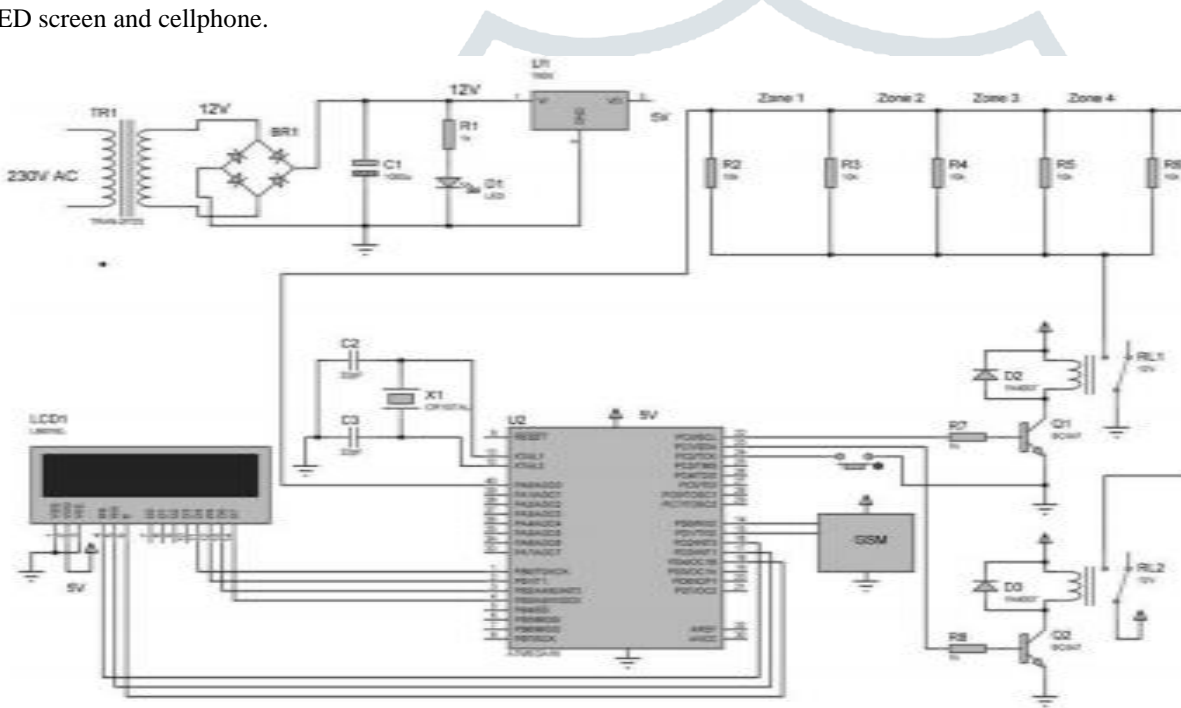

5. Components Used:

5.1 Power supply:

The power supply circuit consists of step down transformer which is 230 volts step down to 12 volts. In this circuit four diodes are used to make bridge rectifier circuit which supply pulsating dc voltage and then supply to capacitor filter the output voltage from rectifier is supply to filter to remove any AC components present even after rectification. The rectified DC voltage is given to regulator to produce 12 volts constant DC voltage.

5.2 ATMEGA16 Microcontroller:

AT Mega 16 microcontroller is an 16 bit high speed micro controller from the Atmel's Mega family. Atmega16 microcontroller is a 16 bit 40 pin micro controller based on enhanced (Reduced instruction set computing) RISC architecture with 131 instruction. The input supply is given to the voltage regulator which also drives a relay driver which controls the relays for proper connection of the Underground cable. If fault occur in relay will be open to switch on alarm of faulty section. LCD display fault location and Arduino send a message using micro controller through GSM & GPS Module in mobile phone.

5.3 LCD Display:

16x2 LCD has 16 Columns and 2 Rows. There are a lot of combinations of LCD's are available like, 8x1, 8x2, 10x2, 16x1, etc. but the most common one is the 16x2 LCD. So, it will have 32 characters in total and each character will be made of 5x8 Pixels. Operating Voltage - 4.7V to

5.3V Current consumption is 1mA It Consists of two rows and each row can print 16 characters. Each character is build by a 5×8 pixel boxes. It Can work on both 8-bit and 4-bit mode.

5.4 Voltage regulator:

A voltage regulator is an electrical device which is fabricated to maintain a constant voltage level. In this project, power supply 12 volts are required. In order to obtain these voltage levels, voltage regulators are used.

5.6 Rectifier:

The output from the transformer is supplied to the rectifier. It converts A.C. into pulsating D.C. The rectifier should be either half wave or a full wave rectifier. In this system, a bridge rectifier is used because of its advantages like stability. The circuit consist of four diodes connected to form a bridge.

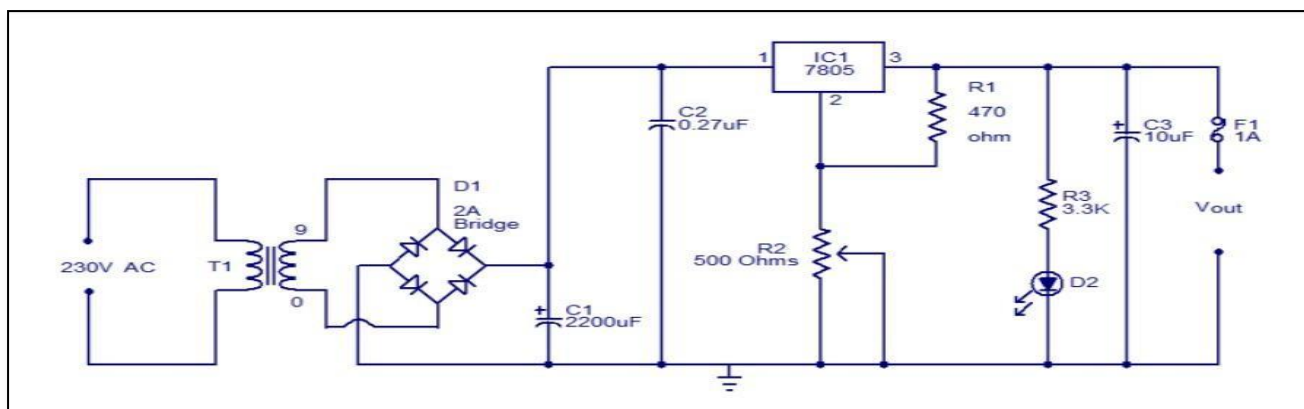

5.7 Relay :

Relay is used as a sensing device which senses the fault to send a trip signal to circuit breaker which isolates the faulty section. A relay is an automatic device by which an electrical circuit is indirectly controlled and is supervised by change in the same or another electrical circuit. Numerical relay, Static relay and electromagnetic relay are the various types of relays. The relays periodically scan the three phases and send the signal to the Atmega16 Microcontroller controller. The rating of each of the relays is about 12V.

5.8 GPS Module :

Global Positioning System (GPS) makes use of signals sent by satellites in space and ground stations on Earth to accurately determine their position on Earth. Radio Frequency signals sent from satellites and ground stations are received by the GPS. GPS makes use of these signals to determine its accurate position.

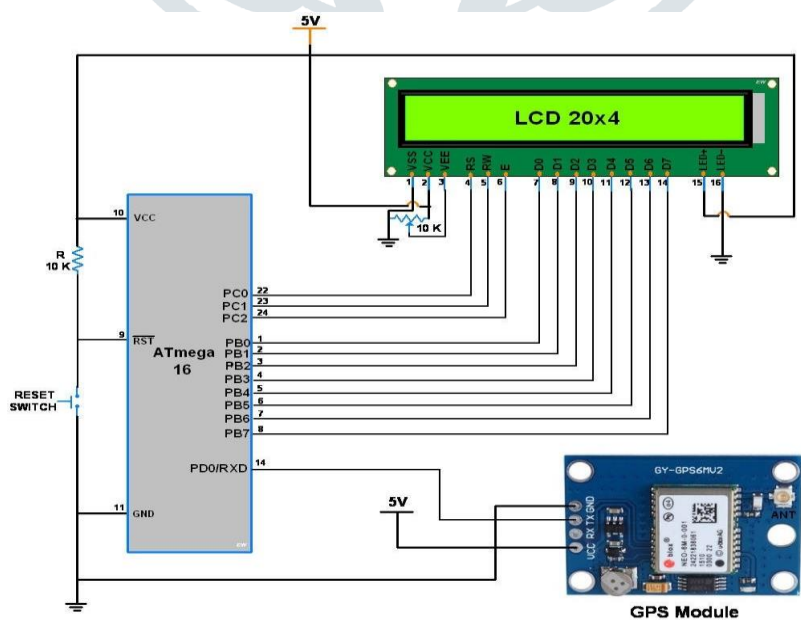

5.9 Transformer :

Transformer is static electrical device which step up or step down electrical energy from one to another circuit with change in voltage/current without change in frequency .in this project we used step down transformer. Usually DC voltage are necessary to operate various electronic devices and this voltage are 5v ,9v or 12v.but this voltage cannot be obtained directly so the AC input available at the main supply. i.e. 230v is step down to the required voltage level by transformer.

6. Existing System:

In A-frame method, a DC pulse is supplied through the faulty cable and earth terminal to locate the ground fault. The DC pulse will flow through the cable and return through earth from the earth fault location back to the ground. The flow of DC pulse through the ground will produce a small DC voltage. A sensitive voltmeter measured the magnitude and direction of the DC voltage along the cable route. Analyzing the results of the measured voltage along the route, the location of the fault in the cable can be detected. This is an accurate method but it is not the fastest one. This method may not work if the return DC finds some easier path back to the earth.

7. Propesed System:

This project deals with Atmega16 microcontroller, GPS, GSM, buzzer and LCD. This proposes greatly reduces the time and operates effectively. The project uses the simple concept of Ohm's law where a low DC voltage is applied at the provider end through series resistor. The current would change depending upon the length (in km) of fault of the cable in case there is a short circuit of LL fault or 3L fault or LG fault etc. When fault occur it send messages through GSM & GPS module on LED screen and cellphone and that's how we get the pinpoint locations of the fault.

8. Result :

Thus the underground cable fault detection system using AT Mega 16 Microcontroller was identified faults in the underground cable from distribution side to load side. To measure the fault between particular distance and location an resistor is connected between zones. Solid State relay is a sensing device which senses any change in voltage/current in a particular location of cable and identified the pinpoint location of the fault and send signal on LED screen through GSM and GPS module.

9. Conclusion :

Thus the project on Underground cable fault detection using AT Mega 16 Micro controller,GPS & GSM module proposed low cost solution to reinforce the fault detection of underground cable. It is secure, robust and less power consuming.

10. References

1. Pooja P.S.and Lakshmi M(2015)'Fault detection technique for Underground Cables '-International Journal of Engineering Research and General science volume 3 issue 3, May-june ,2015
2. Dhekale P.M., Bhise S.S., et al, "Underground Cable Fault Distance Locator", IJIERT, ISSN: 2394-3696, Volume 2, Issue 4, 2015 Dhekale P.M., Bhise S.S., et al, "Underground Cable Fault Distance Locator", ISSN: 2394-3696, Volume 2, Issue 4, 2015
3. Shunmugam.,DivyaJananiT.G ,Megaladevi .P,Mownisha .P.Arduino based underground cable fault detector IJRTER(2016) vol 2
- 4.Abhas, AbhinavShukla and RiwiKomal(2016)'IoT based Underground cable fault detection and monitoring', IJCTA, 9(22), 2016, pp. 145-150
5. Sudesh Pahal , Vaibhav Sapra , Sabya Sachi and Shivani Kukreti "Underground Cable Fault Detection System" Advanced Research in Electrical and Electronic Engineering p-ISSN: 2349-5804; e-ISSN: 2349-5812 Volume 3, Issue 2 January-March, 2016
6. Aqib Al Husan Ansari, Atul Barhate, 'Arduino based Fault Detection in underground cables', International Journal for Research in Engineering Application & Management (IJREAM) ISSN: 2454-9150 Vol-03, Issue 04, May 2017.
7. Abhay Sharma , Akash Mathur , Rajat Gupta , Ranjeet Singh , Er. Mansi Singh (2017) 'Underground Cable Fault Distance Locator'-International Journal of Advanced Research in Electrical, Electronics and Instrumentation Engineering Vol. 6, Issue 4, April 2017
8. T.Nandhini1 , J.Shalini2 , T. Sai Sangeetha3 , D.Gnanaprakasam "Underground Cable Fault Detection using Arduino" Research Article Volume 7 2017 IJESC
9. N.Gayathri, V.Kowsalya, M.Kalidas, S.Deepika AUTOMATIC UNDERGROUND CABLE FAULT DETECTION WITH SMS ALERT International Research Journal of Engineering and Technology (IRJET) Volume: 05 Issue: 02 | Feb-2018