

ENERGY METER OBSERVING AND BILL SUPER VISION USING IOT AND ML

Mr. Rajkumar[1], Simran Bajaj[2], Subham Kumar[3],Karan Singh[4]

[1] Associate Professor [2,3,4] CSE Students, 4th Year, SRM Institute of Science & Technology, Ramapuram, Chennai

Abstract: In this paper, a new procedure is followed based on MICROCONTROLLER Node MCU to detect and monitor the power consumption, faults, and loss. A data will be sent automatically to the utility central server through IOT module. Here Automatic meter reading can be Proposed in the System along with Cloud data analyze is and Money Management with Energy meter report and Billing Displayed in webpage.

A. INTRODUCTION:

Electronic metering technology decreases a great amount of labor pool and time and also make convenient for the people of remote area for paying the bill. It also reduces the non – payment of bill and avoids the mistakes due to manual calculation. Power theft is one of the greatest Problem which our country is facing and with the help of This aim power theft can be greatly reduced.

Consider a complicated power system network, it is very usual to get faults in every branches if the network. In this system all the loads will be monitored and examined through online using IoT.

In case of losses also can be determined by this system by comparing the past values or normal values with present value. If there is any variation occurred can be intimated by this system.

B. RELATED WORKS AND MOTIVATION:

Brinda.S1 et.al (2018) proposed that electricity meter reading for electricity usage and billing is done by human workers from home to home and building to buildings. The prospect of this project is to implement a Smart Electricity meter using GSM. This can reduce human errors and helps to retrieve the real time meter value via GSM and send it to customer's mobile phone through GSM. This also permits electricity board to change the variable package price in particular duration. The administrator can analyse the customer's power consumption data and generate the report from the data online. The prototype will be able to introduce the billing system to the customers, get the power consumption data from smart meter, keep the data in centralized database and generate the report.

Shi-WeiLee et.al. (2002) proposed that a microprocessor-based automatic meter reading system is implemented, which provides a worthwhile, authentic, and intervention free data transmission between remote meter reading units and the utility control center. The meter reading and administration procedure are free from human participation. Based on the existing telephone networks, it is very pliable for the utility companies to access, service and sustain this.

M. Popa (2011) proposed an AMI based system. Smart meters are linked to a gateway through power lines and the gateway transmits with a central computer through GSM. The power line communication is implemented with an industrial bus, Lon Work. The paper focuses the data collection solution.

Ali Abdullah et.al. (2007) proposed that in recent years many engineers and companies have been working on Automatic Meter Reading (AMR), and different media, such as radio, telephone lines, and power lines, have been used for this purpose. Nowadays, GSM network, with its huge coverage in most countries, and also its competitive ever-increasing market, is becoming popular as the main medium for the machine-to-machine applications, and AMR is not an anomaly.

C. SYSTEM DESIGN:

A smart energy meter works on communication directly with wireless data protocol, so there will be accurate reading. Smart energy meters can operate in divergent ways with IOT Module. The proposed system consists of digital energy meter, a node mcu (microcontroller).

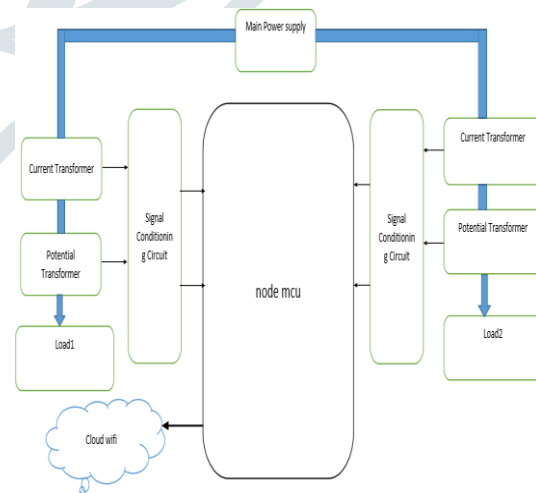

Fig 1 : Block Diagram of the proposed system

The data from energy meter by the help of current and potential transformer will be transmitted to cloud by IOT

module. The stored data can recognize by authorized persons. Terms like power loss, over power usage, instantaneous power, total energy usage, faulty loads, can be recognized by this system. Every branch in the power system can be monitored in every instant of time. In the fig 1 the block diagram is showed.

D. METHODOLOGY:

There is two branches of loads are there in the block diagram. For those branches separate voltage and current transformer pairs are added each will continuously monitor the instantaneous power. Whenever loss occurred the value of dataset will be compared with present values and the fault will be determined, fault in a particular branch can also be determined so that it will be easy for regulating those faults. If any fault occurred it can also be determined by regular check-up, also faulty load can be funded by this system. Fluctuation in voltage will be intimated through sending messages in mobile phones. Also the total system can be controlled through any internet access devices, used to switch on and off the loads from the supply. In the fig 2 monitoring section are showed.

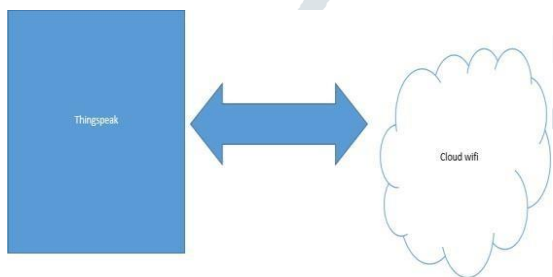

Fig 2: Monitoring section block diagram

Signal conditioning circuit

Voltage transformer is a normal transformer which converts high voltage to particular voltage comfortable for us. Here the microcontroller work in 5 voltages or less than that so by using potential transformer we have to convert (0-230) volt to (0-5) voltage, for that conversion we are using signal conditioning circuit.

In case of current transformer also we are converting current value to a proportional voltage value comfortable to microcontroller.

Drawbacks of the regular energy meter

- Highly depends on meter reader.
- Human error cannot be circumvent for the manual meter reading.
- Always there is no quality assurance or recheck of human readers for energy utilization.

- High chance of theft and corruption always high to misuse it especially during occasion.
- Probability to modify the reading while taking snaps of energy meter by using software tools.
- More number of meter reading employees is extra expenses to the company for hiring them and their expense on travelling too expensive one.
- Wherever energy meter installed in the home, which may lead to non-checking of reading due to lock.
- The consumer is not getting updates of his daily usage of energy.
- The customer may not receive his energy bill as per regular interval of the due date.

Node mcu microcontroller

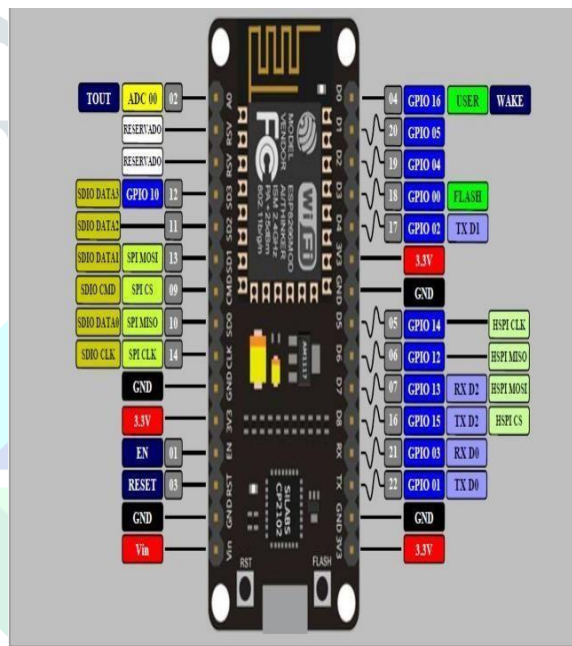

Fig 3: Node MCU Microcontroller

Node MCU is an open source IoT platform. It includes firmware which runs on the ESP8266 Wi-Fi SoC from Expressive Systems, and hardware which is based on the ESP-12 module. It is based upon the eLua project, and built on the Express if Non-OS SDK for ESP8266. It uses several open source projects, such as lua-cjson and SPIFFS. Fig 3 described the node MCU microcontroller.

Current Transformer

The current transformer is connected to raspberry pi. The current transformer is used for measure the current level for the given load. Two branches are used those branches separate current transformer pairs are added each will continuously monitor the instantaneous power.

Voltage Transformer

The voltage transformer is connected to raspberry pi. The voltage transformer is used for measure the voltage level for the given load. Two branches are used those branches separate voltage transformer pairs are added each will continuously monitor the instantaneous power.

E. CONCLUSION:

This paper is the integrated with hardware advantage for both utility and the consumer. NODE MCU, SSR, and iot stationed Energy Meter for smart metering, is built which is able to read and send data via wireless protocol using iot technology through iot module, capable of managing and controlling the supply. In the case of faults, losses, and faulty loads, Power consumption, power quality, and its accuracy can be monitored by the consumers directly.

REFERENCES:

- [1] ZigBee Alliance, ZigBee Specification. version1.1, Nov.2006.
- [2] Zigbee Alliance, Smart Energy Profile Specification, version1.0, March. 11.2009.
- [3] Institute of Electrical and Electronics Engineers, Inc., IEEE Std. 802.15.4-2003, "Wireless Medium Access Control (MAC) and Physical Layer (PHY) Specifications for Low Rate Wireless Personal Area Networks (LR-WPANs)," New York, IEEE Press, Oct. 2003.
- [4] V. Singhvi et al, "Intelligent light control using sensor networks," SenSys '05, 2005.
- [5] M.-S. Pan, L.-W. Yeh, Y.-A. Chen, Y.-H. Lin, and Y.-C. Tseng, "Design and implementation of awsn-based intelligent light control system," ICDCSW '08, pp. 321-326, 2008.
- [6] I. F. Akyildiz, W. J. Su, Y. Sankarasubramaniam, E. Cayirci, "Wireless sensor networks: a survey," Computer Networks, vol. 38, pp. 393– 422, Oct.2002.
- [7] Tasshik. Shon, Yongsuk Park, "A Hybrid Adaptive Security Framework for IEEE 802.15.4-based Wireless Sensor Networks," KSII Transactions on Internet and Information Systems.vol.3, no.6, Dec. 2009.
- [8] Heemin. Park, Jeff. Burke,Mani B. Srivastava, " Intelligent Lighting Control using Wireless Sensor Networks for Media Production," KSII Transactions on Internet and Information Systems.vol.3, no.5,Oct. 2009.
- [9] Changsu, Suh. Yong Bae, Ko."Design and Implementation of Intelligent Home Control Systems based on Active Sensor Networks" IEEE Transactions on Consumer Electronics, vol.54, no.3, Aug. 2008.
- [10] Liu. Yanfei, Wang. Cheng, Yu. Chengbo, Qiao. Xiaojun, "Research on ZigBee Wireless Sensors Network Based on ModBus Protocol," Information Technology and Applications, 2009. IFITA '09.
- [11] IEEE Computer Society, MAC and PHY Specifications for Low-Rate Wireless Personal Area Networks (LR-WPANs), IEEE 802.15.4 TM- 2003.
- [12] IEEE Computer Society, Low-Rate Alternative PHY Task Group of IEEE 802.15.4 (TG4a) for the ranging and location, IEEE 802.15.4a- 2007.
- [13] T. Yamazaki, "Ubiquitous Home," International Journal of Smart Home, vol. 1, no. 1, pp. 17-22, 2007.
- [14] A True System-on-Chip solution for 2.4 GHz IEEE 802.15.4 / ZigBee.
- [15] Wei Yuan, Xiangyu Wang, Jean-Paul M.G. Linnartz, "A Coexistence Model of IEEE 802.15.4 and IEEE 802.11b/g," IEEE Symposium on Communications and Vehicular Technology, Nov. 2007.
- [16] Roy.A, Das.S.K, Basu. K, "A Predictive Framwork for Location-Aware Resource Management in Smart Homes," IEEE Transaction on Mobile Computing, vol.6, pp.1270-1283, Nov. 2007.
- [17] Joseph. B. Kruskal,"On the Shortest Spanning Subtree of a Graph and the Traveling Salesman Problem," In Proceedings of the American Mathematical Society, vol. 7, no. 1, pp. 48–50, Feb. 1956.
- [18] Seong Hoon Kim, Jeong Seok Kang, Hong Seong Park, Daeyoung Kim, Young-joo Kim, "UPnP-ZigBee internetworking architecture mirroring a multi-hop ZigBee network topology ,"Consumer Electronics, IEEE Transactions on, vol. 55 , pp. 1286 - 1294 2009.
- [19] Heemin Park, Jeff Burke, Mani B. Srivastava, " Intelligent Light Control using Wireless Sensor Networks for Media Production," KSII Transactions on Internet and Information Systems, vol. 3, no.5, pp. 423- 443, Oct. 2009.
- [20] Valero.M.A, Valillo.L, Penalval.A, "AN Implementation Framework for Smart Home Telecare Services," Future Generation communication and networking (fgcn 2007), vol. 2, pp.60-65, Dec. 2007.